

VALVE SIZE	A		B		C		WEIGHT KGS
	mm	inch	mm	inch	mm	inch	
DN15 SC	240	9.45	95	3.74	67.5	2.66	1.9
DN15 SO	240	9.45	95	3.74	67.5	2.66	2.0
DN15 DA	240	9.45	95	3.74	67.5	2.66	1.7

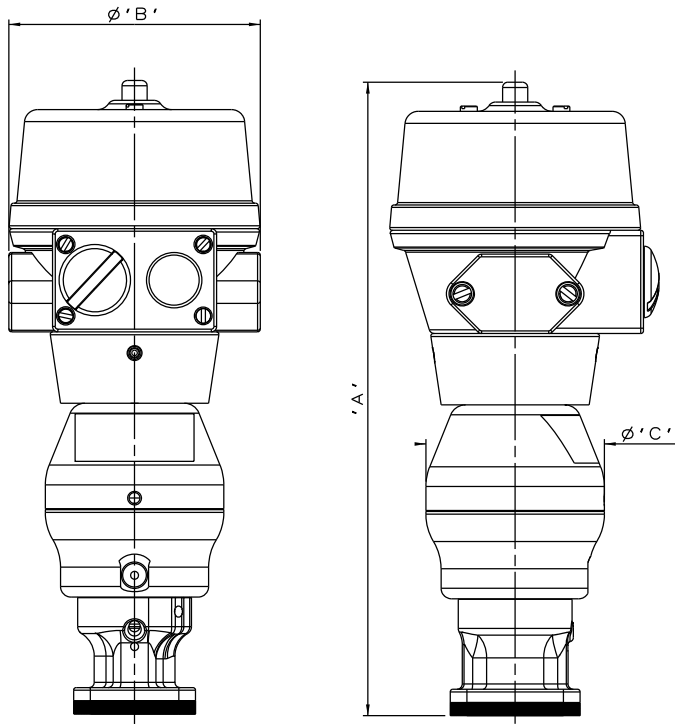

DN15 S360 ø50 PISTON  
SPRING CLOSING

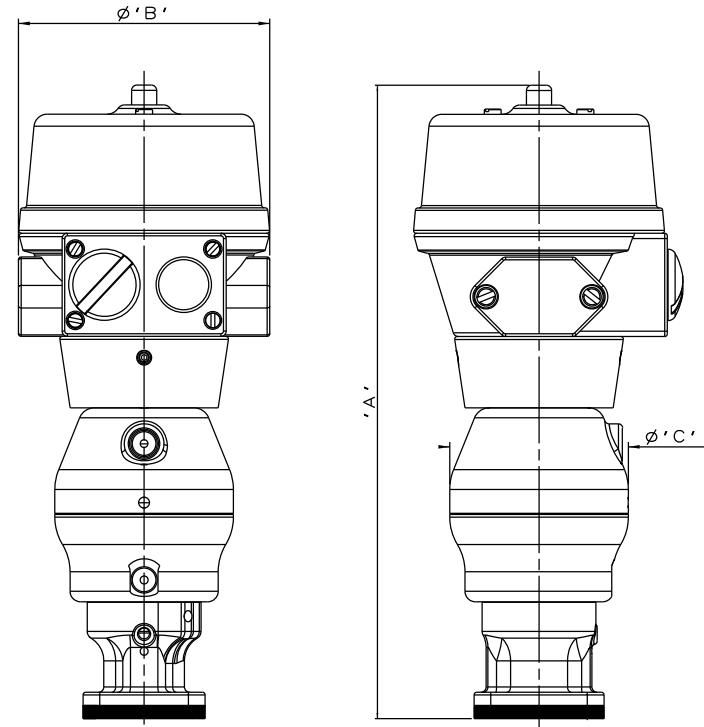

DN15 S360 ø50 PISTON  
SPRING OPENING/DOUBLE ACTING

The information on this sheet is Private and Confidential and is the property of Crane Process Flow Technologies Limited and must not be published directly or indirectly in any manner whatsoever without the written permission of the Company and must not be used in any way detrimental to their interests.  
© Crane Process Flow Technologies

**CRANE** Process Flow Technologies  
A Crane Co. Company

**Saunders**  
The Science Inside

Title			
LEADING DIMENSIONS FOR DN15 ø50 PISTON ACTUATORS FITTED WITH MODULE SWITCHBOXES			
Drawn NAW	Date 29.08.12	UNCONTROLLED IN HARD COPY FORMAT	
Checked RND	Date 29.08.12		
First Angle Projection Method E		DO NOT SCALE	Drawing No. WEB-238
			Issue. 1