

VALVE SIZE	A		B		C		D		E		WEIGHT
	mm	inch	mm	inch	mm	inch	mm	inch	mm	inch	KGS
DN50 SC LITE	314	12.36	71	2.79	71.5	2.81	136	5.35	123	4.84	8.3
DN50 SO	323	12.72	71	2.79	71.5	2.81	136	5.35	150	5.91	10.3
DN50 DA	323	12.72	71	2.79	71.5	2.81	136	5.35	150	5.91	10.0
DN50 SC POWER	323	12.72	71	2.79	71.5	2.81	136	5.35	150	5.91	10.3

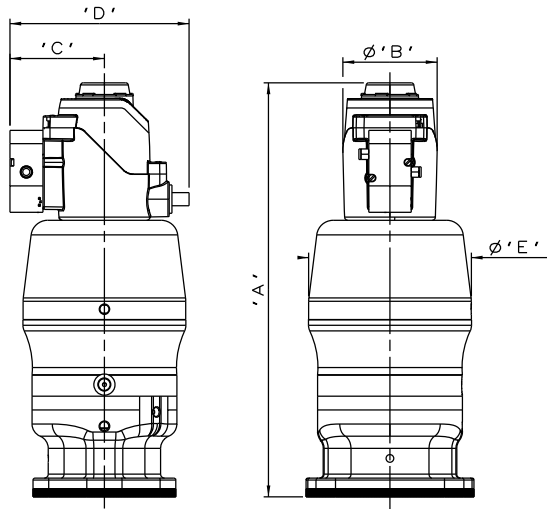

DN50 LITE S360 Ø100 PISTON
SPRING CLOSING

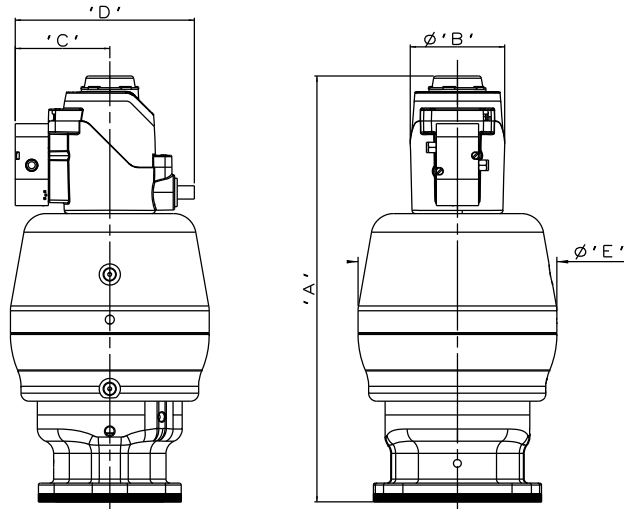

DN50 S360 Ø125 PISTON
SPRING OPENING/DOUBLE ACTING

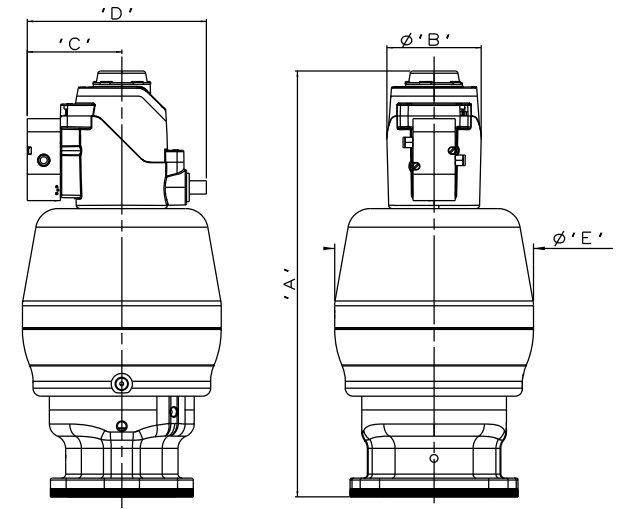

DN50 POWER S360 Ø125 PISTON
SPRING CLOSING

The information on this sheet is Private and Confidential and is the property of Crane Process Flow Technologies Limited and must not be published directly or indirectly in any manner whatsoever without the written permission of the Company and must not be used in any way detrimental to their interests.
© Crane Process Flow Technologies

CRANE Process Flow Technologies
A Crane Co. Company

Saunders
The Science Inside

Title
LEADING DIMENSIONS FOR DN50
Ø100/125 PISTON ACTUATORS
FITTED WITH SAUNDERS IVUE SENSOR

Drawn JRD	Date 29.08.12	UNCONTROLLED IN HARD COPY FORMAT
Checked RND	Date 29.08.12	
First Angle Projection Method E		DO NOT SCALE
Drawing No. WEB-235		Issue. 1