

VALVE SIZE	A		B		C		D		E		WEIGHT
	mm	inch	mm	inch	mm	inch	mm	inch	mm	inch	KGS
DN25 SC LITE	241	9.49	71	2.79	71.5	2.81	136	5.35	88	3.46	2.9
DN25 SO	253	9.96	71	2.79	71.5	2.81	136	5.35	98	3.86	3.5
DN25 DA	253	9.96	71	2.79	71.5	2.81	136	5.35	98	3.86	3.3
DN25 SC POWER	253	9.96	71	2.79	71.5	2.81	136	5.35	98	3.86	3.5

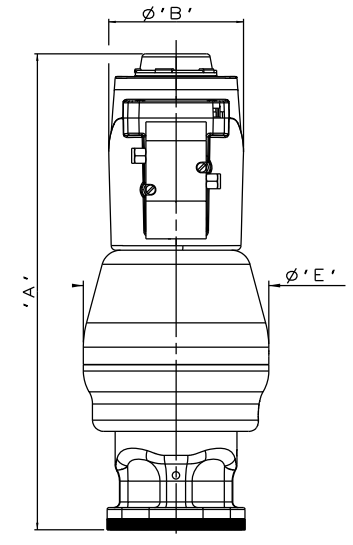
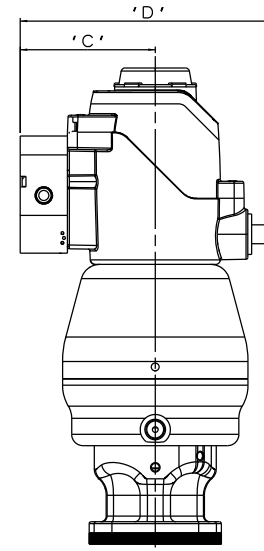
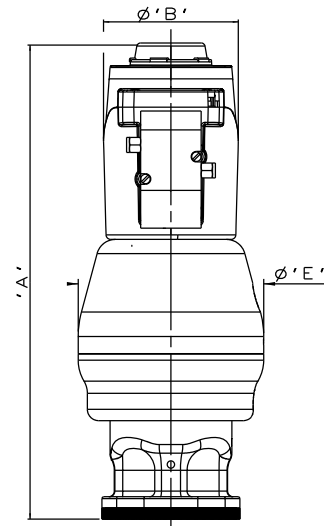
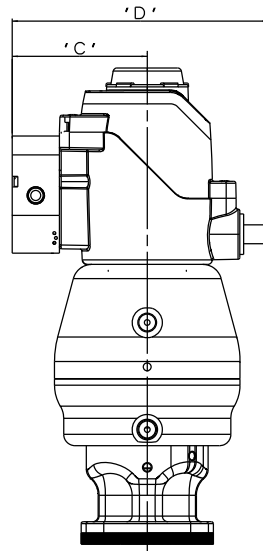
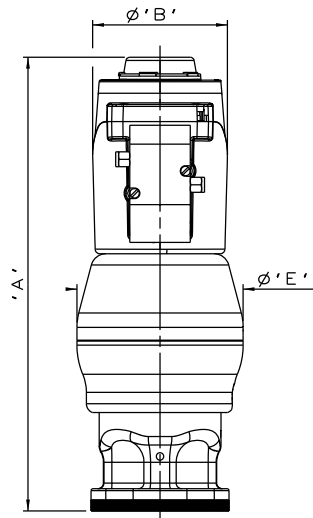
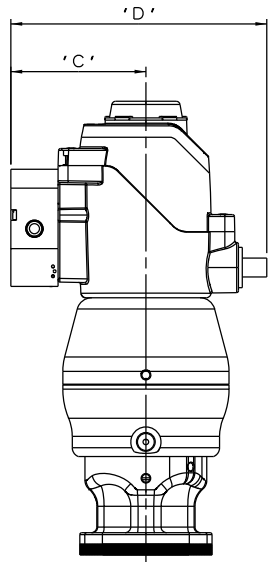

DN25 LITE S360 ϕ 70 PISTON
SPRING CLOSING

DN25 S360 ϕ 80 PISTON
SPRING OPENING/DOUBLE ACTING

DN25 POWER S360 ϕ 80 PISTON
SPRING CLOSING

The information on this sheet is Private and Confidential and is the property of Crane Process Flow Technologies Limited and must not be published directly or indirectly in any manner whatsoever without the written permission of the Company and must not be used in any way detrimental to their interests.
© Crane Process Flow Technologies

CRANE Process Flow Technologies
A Crane Co. Company

Saunders
The Science Inside

Title
LEADING DIMENSIONS FOR DN25
 ϕ 70/ ϕ 80 PISTON S360 ACTUATORS
FITTED WITH SAUNDERS IVUE SENSOR

Drawn JRD	Date 29.08.12	UNCONTROLLED IN HARD COPY FORMAT
Checked RND	Date 29.08.12	
First Angle Projection Method E	DO NOT SCALE	Drawing No. WEB-233
		Issue. 1