

VALVE SIZE	A		B		C		D		E		WEIGHT
	mm	inch	mm	inch	mm	inch	mm	inch	mm	inch	KGS
DN15 SC	222	8.74	71	2.79	71.5	2.81	136	5.35	67.5	2.66	1.8
DN15 SO	222	8.74	71	2.79	71.5	2.81	136	5.35	67.5	2.66	1.9
DN15 DA	222	8.74	71	2.79	71.5	2.81	136	5.35	67.5	2.66	1.6

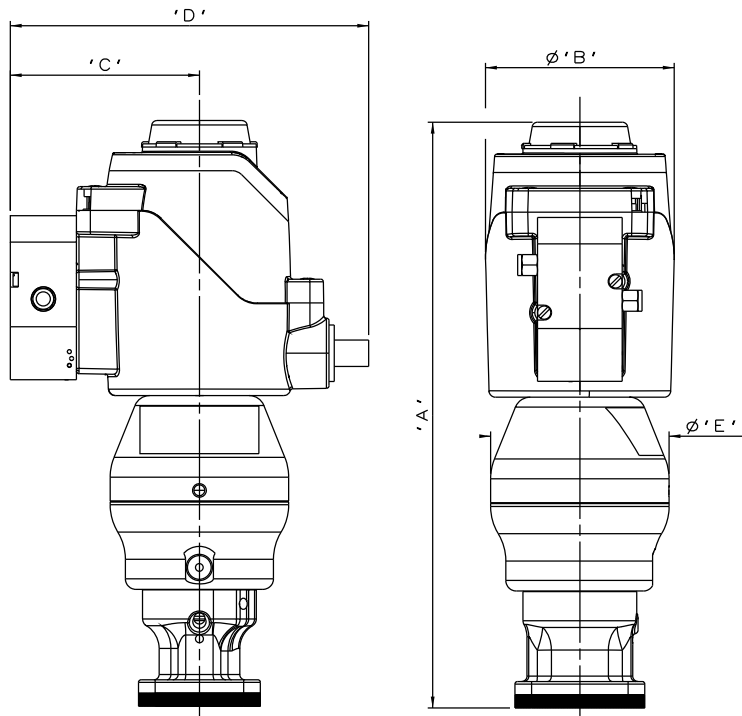

DN15 S360 ø50 PISTON
SPRING CLOSING

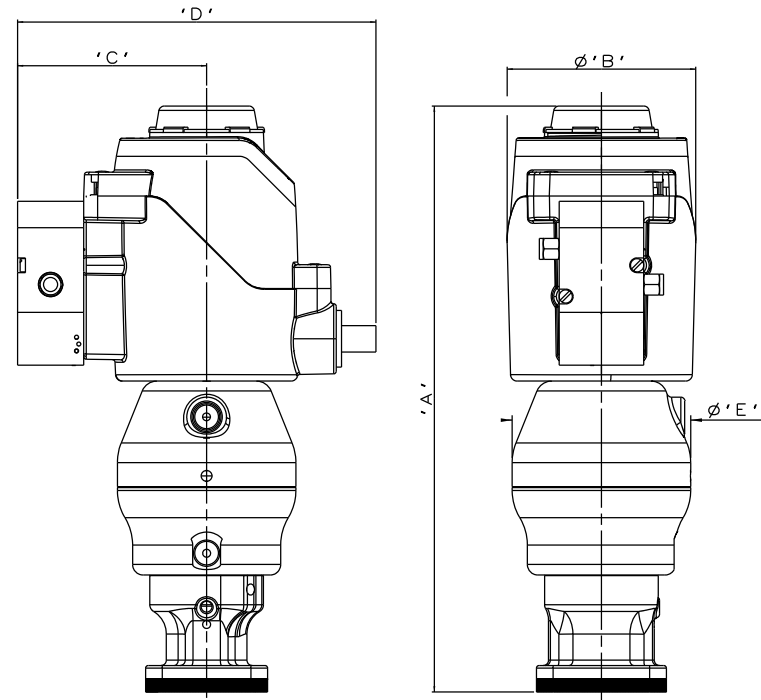

DN15 S360 ø50 PISTON
SPRING OPENING/DOUBLE ACTING

The information on this sheet is Private and Confidential and is the property of Crane Process Flow Technologies Limited and must not be published directly or indirectly in any manner whatsoever without the written permission of the Company and must not be used in any way detrimental to their interests.
© Crane Process Flow Technologies

CRANE Process Flow Technologies
A Crane Co. Company

Saunders
The Science Inside

Title
LEADING DIMENSIONS FOR DN15
ø50 PISTON ACTUATORS
FITTED WITH SAUNDERS IUVUE SENSOR

Drawn JRD	Date 29.08.12	UNCONTROLLED IN HARD COPY FORMAT
Checked RND	Date 29.08.12	
First Angle Projection Method E	DO NOT SCALE	Drawing No. WEB-231
		Issue. 1