

VALVE SIZE	A		B		C		WEIGHT
	mm	inch	mm	inch	mm	inch	KGS
DN15 SC	255	10.05	74	2.92	67.5	2.66	1.5
DN15 SO	255	10.05	74	2.92	67.5	2.66	1.6
DN15 DA	255	10.05	74	2.92	67.5	2.66	1.3

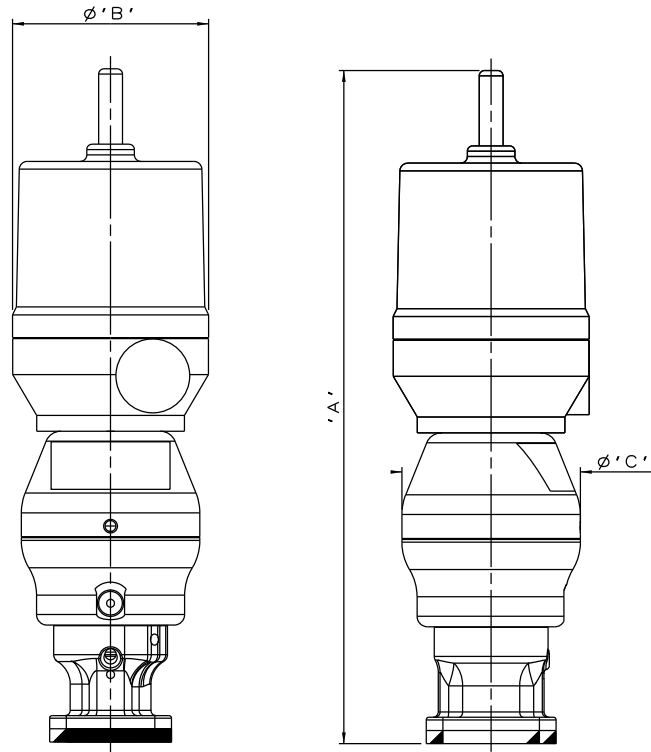

DN15 S360 ϕ 50 PISTON
SPRING CLOSING

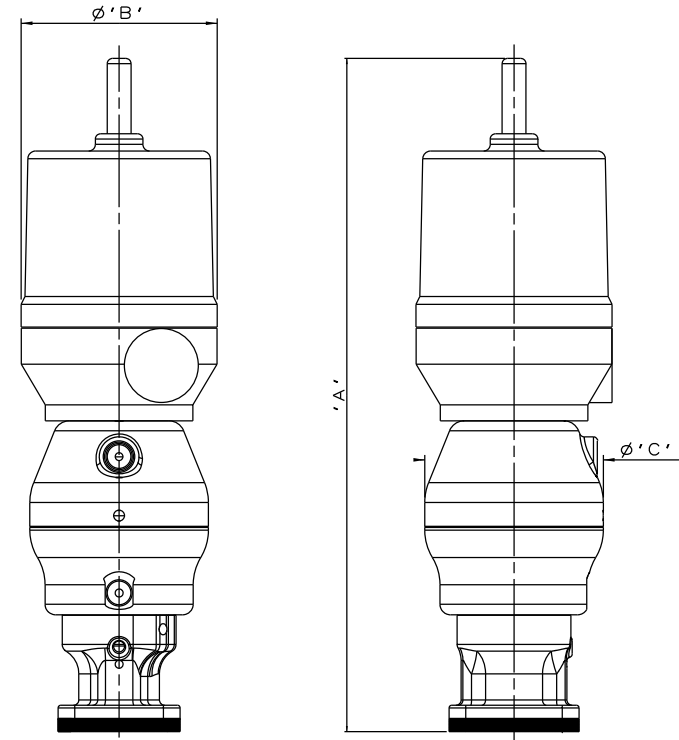

DN15 S360 ϕ 50 PISTON
SPRING OPENING/DOUBLE ACTING

The information on this sheet is Private and Confidential and is the property of Crane Process Flow Technologies Limited and must not be published directly or indirectly in any manner whatsoever without the written permission of the Company and must not be used in any way detrimental to their interests.
© Crane Process Flow Technologies

CRANE Process Flow Technologies
A Crane Co. Company

Saunders
The Science Inside

Title
LEADING DIMENSIONS FOR DN15
 ϕ 50 PISTON ACTUATORS
FITTED WITH OPTI-SET SWITCHBOXES

Drawn NAW	Date 29.08.12	UNCONTROLLED IN HARD COPY FORMAT
Checked RND	Date 29.08.12	
First Angle Projection Method E		DO NOT SCALE
Drawing No. WEB-203		Issue. 1