

DN50 MAINLINE ONLY

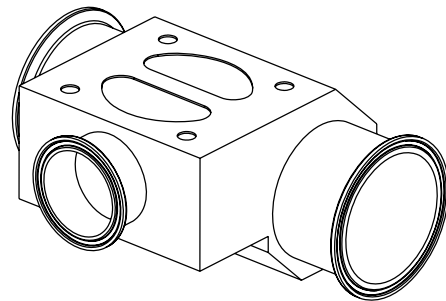

DN80 TO DN100
MAINLINE ONLY

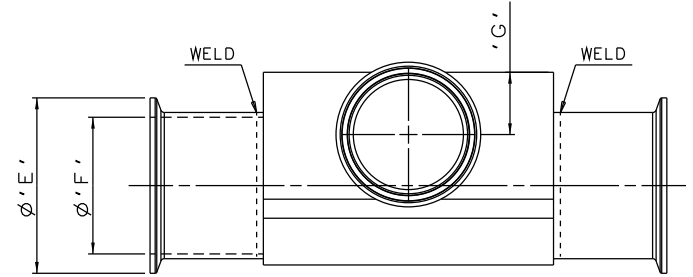
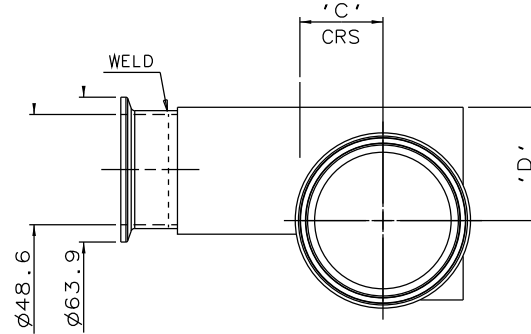
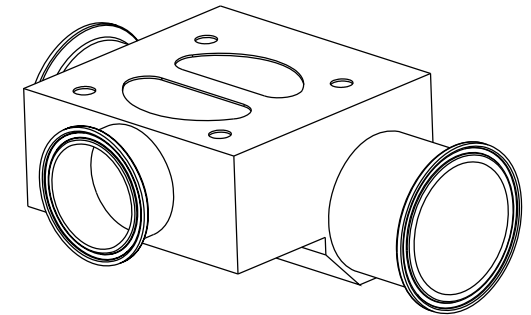
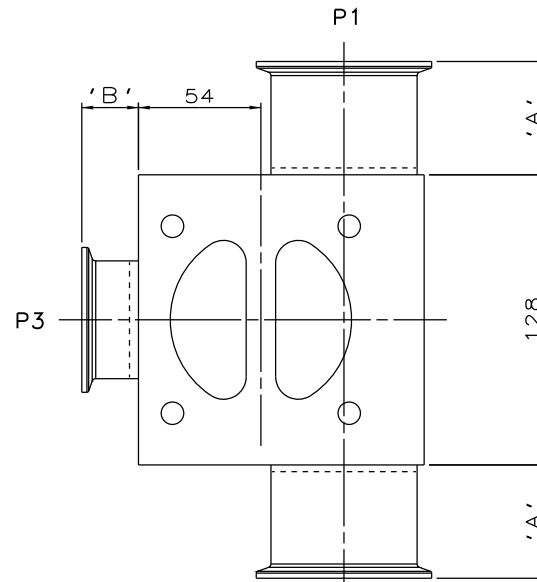

DN65 MAINLINE ONLY

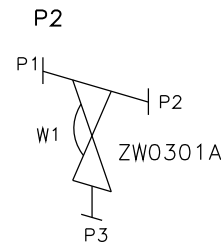

ORIENTATION AS
PER P&ID DIAGRAM
FOR OPTIMUM
DRAINABILITY.

MAINLINE SIZE	A	B	C	D	øE	øF	G	BODY WEIGHT
mm	mm	mm	mm	mm	mm	mm	mm	Kgs
DN50	25.0	25.0	55.3	66.0	51.0	48.6	27.5	4.3
DN65	50.0	25.0	36.7	50.0	63.5	60.3	27.5	5.5
DN80	50.0	25.0	42.5	55.3	76.1	72.9	33.2	5.4
DN100	50.0	25.0	55.3	66.0	101.6	97.6	27.5	6.8

The information on this sheet is Private and Confidential and is the property of Crane Process Flow Technologies Limited and must not be published directly or indirectly in any manner whatsoever without the written permission of the Company and must not be used in any way detrimental to their interests.
© Crane Process Flow Technologies

CRANE Process Flow Technologies
A Crane Co. Company

Saunders
The Science Inside

Title
SCHEDULE OF LEADING DIMENSIONS FOR DN50
WEIR 'T' BODY COMPLETE WITH :
MAINLINE : HYGIENIC CLAMP ENDS WITH SMS 3008 BORE
BRANCH : DN50 HYGIENIC CLAMP END WITH SMS 3008 BORE

Drawn JRD	Date 27.02.12	UNCONTROLLED IN HARD COPY FORMAT	
Checked RND	Date 27.02.12		
First Angle Projection Method E	DO NOT SCALE	Drawing No. WEB-156	Issue. 1