

DN40 MAINLINE ONLY

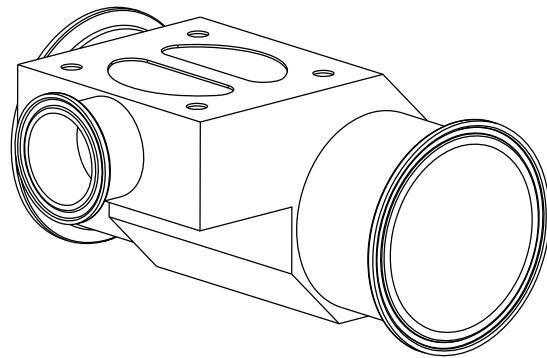

DN80 TO DN100
MAINLINE ONLY

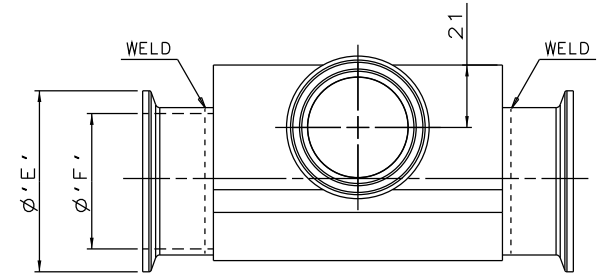
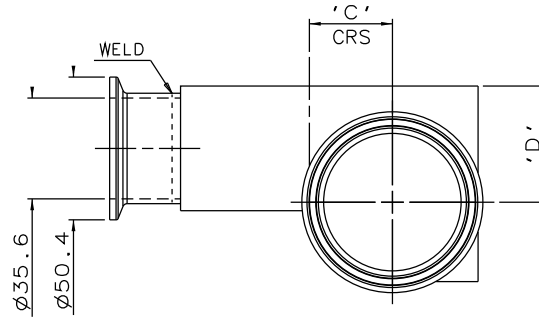
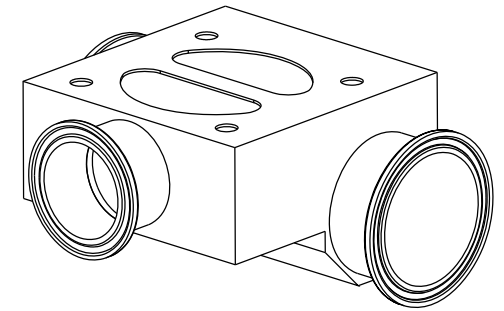
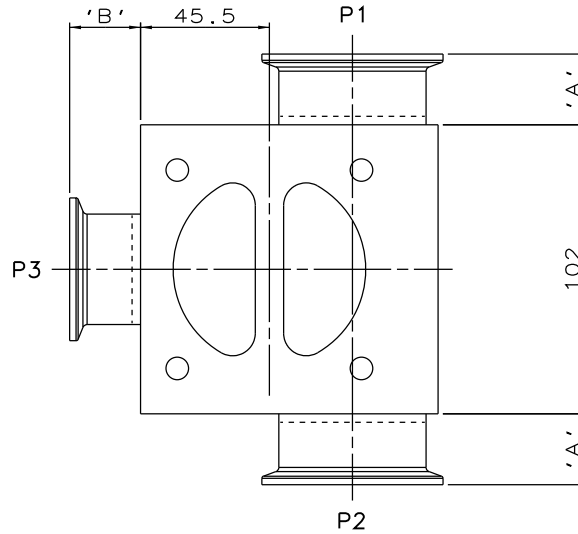

DN50 TO DN65
MAINLINE ONLY

MAINLINE SIZE mm	A mm	B mm	C mm	D mm	ØE mm	ØF mm	BODY WEIGHT Kgs
DN40	25.0	25.0	22.8	32.0	50.4	35.6	2.3
DN50	25.0	25.0	29.3	41.0	63.9	48.6	2.9
DN65	50.0	25.0	36.5	47.0	77.4	60.3	3.6
DN80	50.0	25.0	42.8	52.5	90.9	72.9	3.3
DN100	50.0	25.0	53.8	60.8	118.9	97.6	4.2

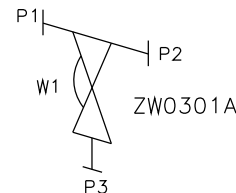

ORIENTATION AS
PER P&ID DIAGRAM
FOR OPTIMUM
DRAINABILITY.

The information on this sheet is Private and Confidential and is the property of Crane Process Flow Technologies Limited and must not be published directly or indirectly in any manner whatsoever without the written permission of the Company and must not be used in any way detrimental to their interests.
© Crane Process Flow Technologies

CRANE Process Flow Technologies
A Crane Co. Company

Saunders
The Science Inside

Title
SCHEDULE OF LEADING DIMENSIONS FOR DN40
WEIR 'T' BODY COMPLETE WITH :
MAINLINE : HYGIENIC CLAMP ENDS WITH SMS 3008 BORE
BRANCH : DN40 HYGIENIC CLAMP END WITH SMS 3008 BORE

Drawn JRD Date 27.02.12 UNCONTROLLED IN
Checked RND Date 27.02.12 HARD COPY FORMAT

First Angle Projection Method E DO NOT SCALE Drawing No. WEB-155 Issue. 1