

DN8/0.25 TO DN50/2.00

ORIENTATION AS PER P&ID DIAGRAM FOR OPTIMUM DRAINABILITY

PAGE 1 OF 2

The information on this sheet is Private and Confidential and is the property of Crane Process Flow Technologies Limited and must not be published directly or indirectly in any manner whatsoever without the written permission of the Company and must not be used in any way detrimental to their interests.
© Crane Process Flow Technologies

CRANE	Process Flow Technologies A Crane Co. Company	Saunders The Science Inside
--------------	--	---------------------------------------

VALVE SIZE		øA		øB		øC		øD		E		øF		G		H		I		J		BODY WEIGHT
mm	inch	mm	inch	mm	inch	mm	inch	mm	inch	mm	inch	mm	inch	mm	inch	mm	inch	mm	inch	mm	inch	Kgs
DN8 (DN15 END)	0.25 (0.50)	12.7	0.50	9.4	0.37	12.7	0.50	9.4	0.37	8.4	0.33	39.3	1.55	28.0	1.10	50.8	2.00	36.0	1.42	58.8	2.31	0.9
DN15	0.50	12.7	0.50	9.4	0.37	12.7	0.50	9.4	0.37	8.4	0.33	39.3	1.55	28.0	1.10	50.8	2.00	50.0	1.97	58.8	2.31	1.21
DN20	0.75	19.05	0.75	15.75	0.62	19.05	0.75	15.75	0.62	11.5	0.45	43.0	1.69	33.0	1.30	50.8	2.00	58.0	2.28	58.8	2.31	1.89
DN25	1.00	25.4	1.00	22.1	0.87	25.4	1.00	22.1	0.87	14.7	0.58	62.0	2.44	45.7	1.80	50.8	2.00	70.0	2.76	58.8	2.31	3.98
DN40	1.50	38.1	1.50	34.8	1.37	38.1	1.50	34.8	1.37	21.1	0.83	70.1	2.76	56.1	2.21	50.8	2.00	91.0	3.58	58.8	2.31	7.30
DN50	2.00	50.8	2.00	47.5	1.87	50.8	2.00	47.5	1.87	27.4	1.08	90.0	3.54	72.4	2.85	50.8	2.00	108.0	4.25	62.8	2.47	14.12

Title		
SCHEDULE OF LEADING DIMENSIONS FOR DN8/0.25 TO DN50/2.00 3-WAY DIVERTER VALVES WITH BUTT WELD OD TUBE ENDS		
Drawn JRD	Date 11.10.11	UNCONTROLLED IN HARD COPY FORMAT
Checked RND	Date 05.11.12	
First Angle Projection Method E	DO NOT SCALE	Drawing No. WEB-069
		Issue. 3

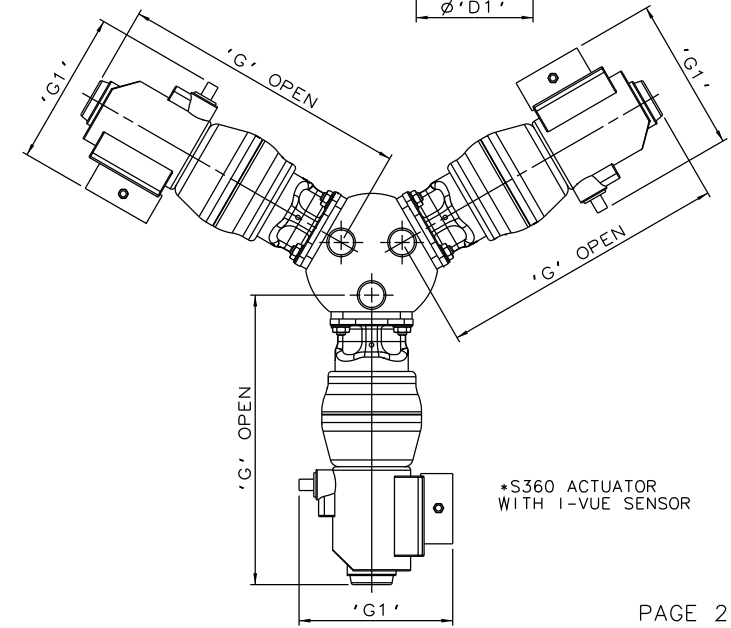
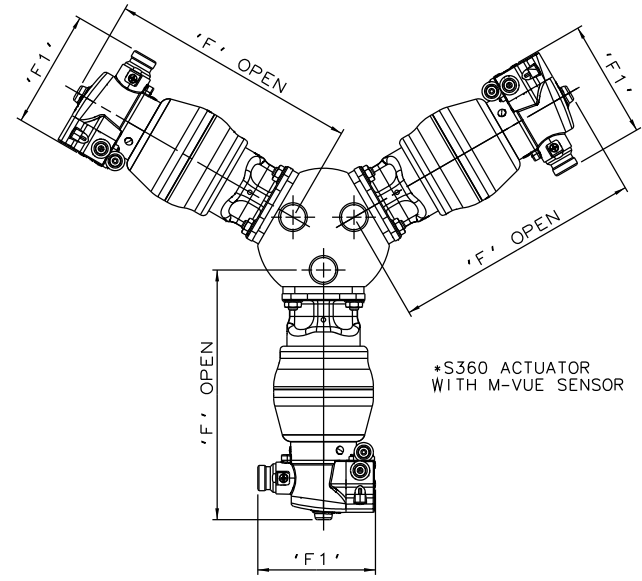
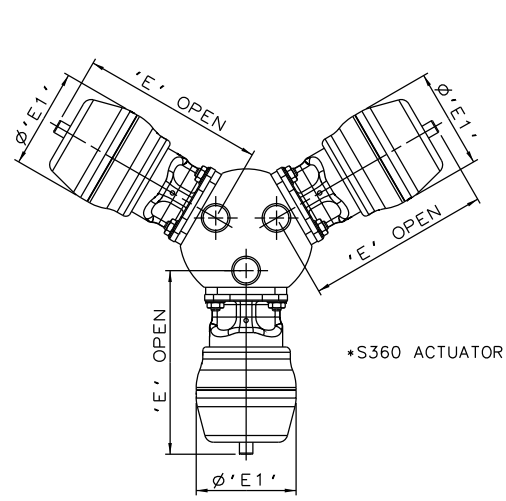
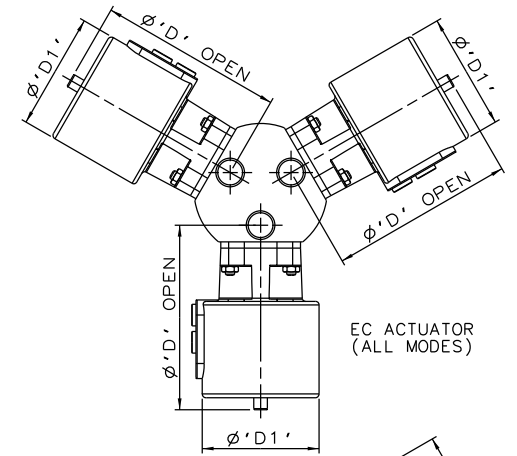
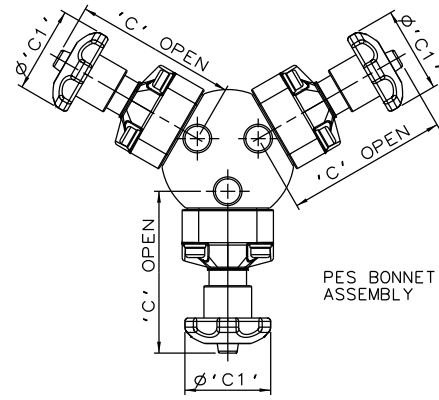
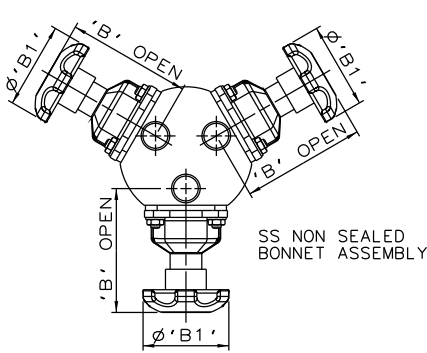
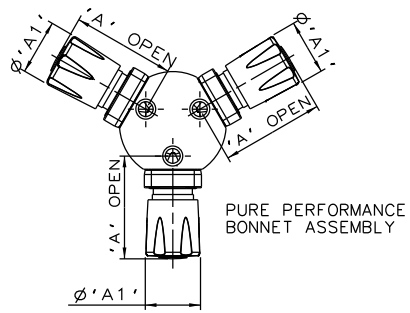

The information on this sheet is Private and Confidential and is the property of Crane Process Flow Technologies Limited and must not be published directly or indirectly in any manner whatsoever without the written permission of the Company and must not be used in any way detrimental to their interests.
 © Crane Process Flow Technologies

CRANE	Process Flow Technologies A Crane Co. Company	Saunders The Science Inside
--------------	--	---------------------------------------

* DIMENSIONS SHOW MAXIMUM ENVELOPE FOR ALL MODES

VALVE SIZE	A	A1	B	B1	C	C1	D	D1	E	E1	F	F1	G	G1	
mm	inch	mm	inch	mm	inch	mm	inch	mm	inch	mm	inch	mm	inch	mm	inch
DN8 (DN15 END)	0.25 (0.50)	64.8	2.55	34.0	1.34	N/A	N/A	N/A	N/A	N/A	N/A	N/A	N/A	N/A	N/A
DN15	0.50	N/A	N/A	N/A	N/A	83.4	3.28	62.0	2.44	106.4	4.19	62.0	2.44	110.4	4.35
DN20	0.75	N/A	N/A	N/A	N/A	86.5	3.41	62.0	2.44	112.5	4.43	62.0	2.44	155.5	6.12
DN25	1.00	N/A	N/A	N/A	N/A	108.7	4.28	80.0	3.15	142.7	5.62	80.0	3.15	162.7	6.41
DN40	1.50	N/A	N/A	N/A	N/A	157.1	6.19	120.0	4.72	198.1	7.80	140.0	5.51	224.1	8.82
DN50	2.00	N/A	N/A	N/A	N/A	179.4	7.06	120.0	4.72	208.4	8.20	140.0	5.51	243.4	9.58

Title: SCHEDULE OF LEADING DIMENSIONS FOR DN8/0.25 TO DN50/2.00 3-WAY DIVERTER VALVES WITH BUTT WELD OD TUBE ENDS. FITTED WITH TOPWORKS OPTIONS

Drawn RI Date 30.06.16 UNCONTROLLED IN HARD COPY FORMAT
 Checked RND Date 30.06.16

First Angle Projection Method E DO NOT SCALE Drawing No. WEB-069-ASSY Issue. 1