

DN8/0.25 TO DN15/0.50
MAINLINE ONLY

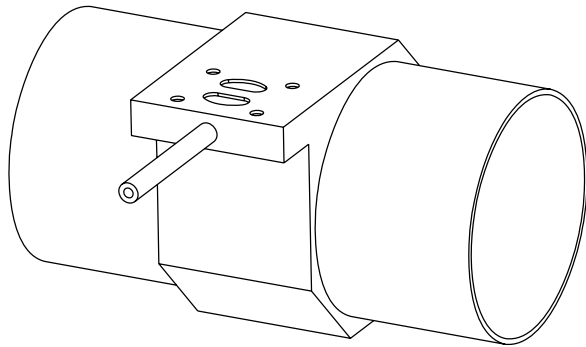

DN80/3.00 TO DN100/4.00
MAINLINE ONLY

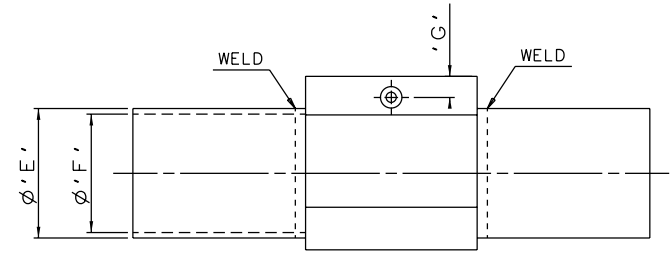
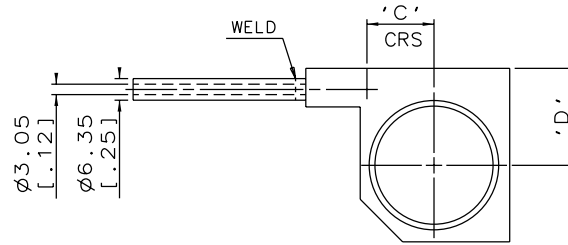
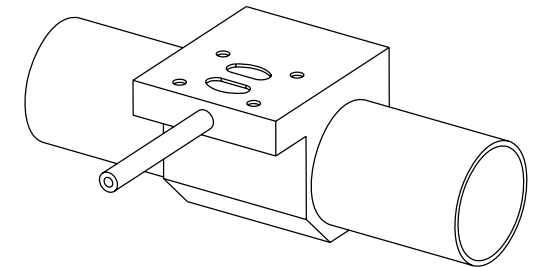
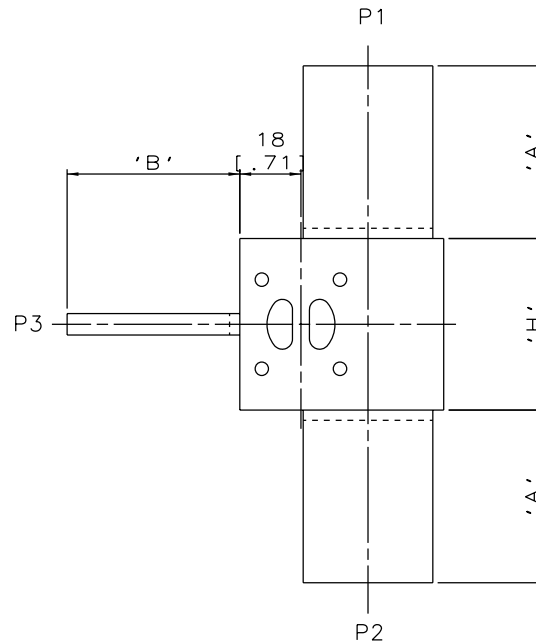

DN20/0.75 TO DN65/2.50
MAINLINE ONLY

MAINLINE SIZE		A		B		C		D		ϕE		ϕF		G		H		BODY WEIGHT
mm	inch	mm	inch	mm	inch	mm	inch	mm	inch	mm	inch	mm	inch	mm	inch	mm	inch	Kgs
DN8	0.25	50.8	2.00	50.8	2.00	3.8	0.15	6.2	0.24	6.35	0.25	3.05	0.12	6.2	0.24	37.0	1.46	0.2
DN15	0.50	50.8	2.00	50.8	2.00	7.2	0.28	16.5	0.65	12.7	0.50	9.4	0.37	5.2	0.20	50.5	1.99	0.4
DN20	0.75	50.8	2.00	50.8	2.00	10.2	0.40	21.0	0.83	19.05	0.75	15.75	0.62	6.2	0.24	50.5	1.99	0.4
DN25	1.00	50.8	2.00	50.8	2.00	13.6	0.54	24.0	0.94	25.4	1.00	22.1	0.87	5.2	0.20	50.5	1.99	0.5
DN40	1.50	50.8	2.00	50.8	2.00	19.7	0.78	28.5	1.12	38.1	1.50	34.8	1.37	6.2	0.24	50.5	1.99	0.7
DN50	2.00	50.8	2.00	50.8	2.00	26.1	1.03	33.2	1.31	50.8	2.00	47.5	1.87	6.2	0.24	50.5	1.99	0.9
DN65	2.50	50.8	2.00	50.8	2.00	32.6	1.28	36.0	1.42	63.5	2.50	60.2	2.37	5.2	0.20	50.5	1.99	1.0
DN80	3.00	50.8	2.00	50.8	2.00	39.0	1.54	41.1	1.62	76.2	3.00	72.9	2.87	5.2	0.20	50.5	1.99	1.0
DN100	4.00	101.6	4.00	50.8	2.00	51.3	2.02	53.8	2.12	101.6	4.00	97.38	3.84	5.2	0.20	50.5	1.99	2.1

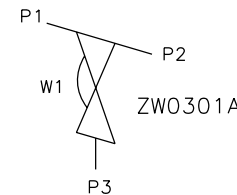

ORIENTATION AS
PER P&ID DIAGRAM
FOR OPTIMUM
DRAINABILITY.

The information on this sheet is Private and Confidential and is the property of Crane Process Flow Technologies Limited and must not be published directly or indirectly in any manner whatsoever without the written permission of the Company and must not be used in any way detrimental to their interests.
© Crane Process Flow Technologies

CRANE Process Flow Technologies
A Crane Co. Company

Saunders
The Science Inside

Title
SCHEDULE OF LEADING DIMENSIONS FOR DN8/0.25
WEIR 'T' BODY WITH BUTT WELD OD TUBE ENDS

Drawn R1	Date 29.09.11	UNCONTROLLED IN HARD COPY FORMAT	
Checked RND	Date 08.03.12	Drawing No.	Issue.
First Angle Projection Method E		DO NOT SCALE	WEB-004 2

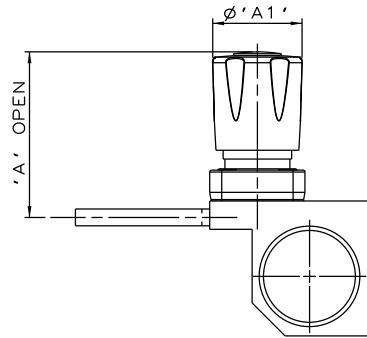

PURE PERFORMANCE
BONNET ASSEMBLY

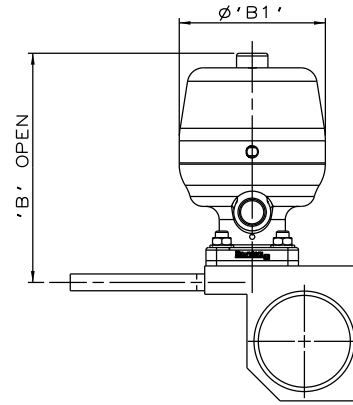

*S360 ACTUATOR

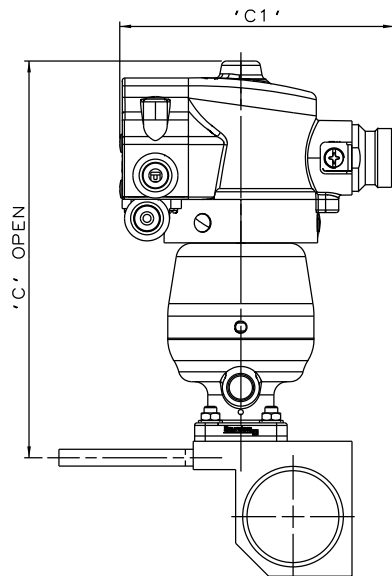

*S360 ACTUATOR
WITH M-VUE SENSOR

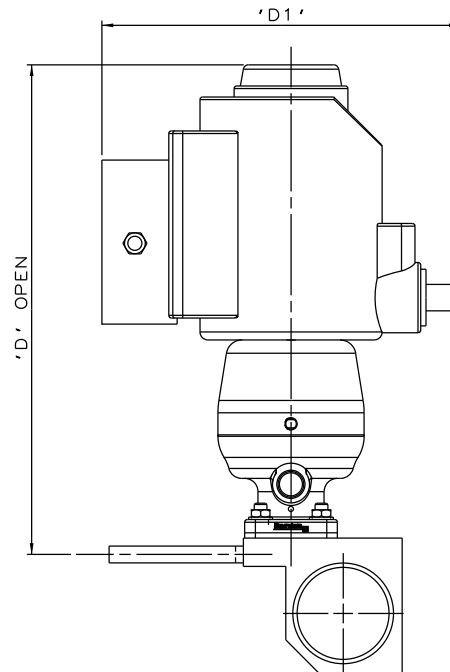

*S360 ACTUATOR
WITH I-VUE SENSOR

The information on this sheet is Private and Confidential and is the property of Crane Process Flow Technologies Limited and must not be published directly or indirectly in any manner whatsoever without the written permission of the Company and must not be used in any way detrimental to their interests.
© Crane Process Flow Technologies

CRANE Process Flow Technologies
A Crane Co. Company

Saunders
The Science Inside

Title
SCHEDULE OF LEADING DIMENSIONS FOR DN8/0.25 WEIR
'T' BODY (DN8/0.25 BRANCH) WITH BUTT WELD OD TUBE ENDS.
FITTED WITH TOPWORKS OPTIONS

Drawn R1	Date 28.06.16	UNCONTROLLED IN HARD COPY FORMAT	
Checked RND	Date 28.06.17		
First Angle Projection Method E	DO NOT SCALE	Drawing No. WEB-004-ASSY	Issue. 1

* DIMENSIONS SHOW MAXIMUM ENVELOPE FOR ALL MODES

BRANCH SIZE		A		A1		B		B1		C		C1		D		D1	
mm	inch	mm	inch	mm	inch	mm	inch	mm	inch	mm	inch	mm	inch	mm	inch	mm	inch
DN8	0.25	62.6	2.46	34.0	1.34	86.2	3.39	55.0	2.18	151.2	5.95	103.8	4.09	185.2	7.39	136.0	5.35