

DN8/0.25  
WEIR SIZE ONLY

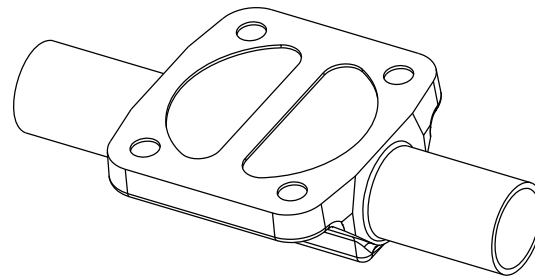

DN15/0.50 TO DN50/2.00  
WEIR SIZE ONLY

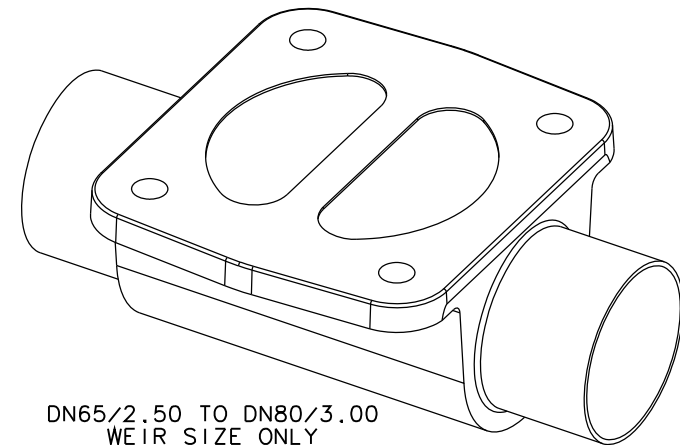

DN65/2.50 TO DN80/3.00  
WEIR SIZE ONLY

VALVE SIZE	A		B		C		øD		øE		F	BODY WEIGHT
mm	inch	mm	inch	mm	inch	mm	inch	mm	inch	mm	DEGREES	Kgs
DN8	0.25	78.0	3.07	21.5	0.85	8.6	0.34	6.35	0.25	3.05	0.12	0.12
DN8 (DN10 END)	0.25 (0.375 END)	78.0	3.07	21.5	0.85	8.6	0.34	9.53	0.38	6.23	0.25	0.12
DN8 (DN15 END)	0.25 (0.50 END)	78.0	3.07	21.5	0.85	8.6	0.34	12.7	0.50	9.4	0.37	0.12
DN15	0.50	130.0	5.12	41.0	1.61	9.4	0.37	12.7	0.50	9.4	0.37	0.21
DN20	0.75	139.7	5.50	39.8	1.57	13.0	0.51	19.05	0.75	15.75	0.62	0.38
DN25	1.00	149.4	5.88	39.7	1.56	15.7	0.62	25.4	1.00	22.1	0.87	0.61
DN40	1.50	177.8	7.00	41.5	1.63	22.0	0.87	38.1	1.50	34.8	1.37	1.16
DN50	2.00	193.5	7.62	42.8	1.69	28.4	1.12	50.8	2.00	47.5	1.87	1.80
DN65	2.50	217.0	8.54	41.5	1.63	40.5	1.59	63.5	2.50	60.2	2.37	4.34
DN80	3.00	254.0	10.00	48.0	1.89	48.0	1.89	76.2	3.00	72.9	2.87	6.88

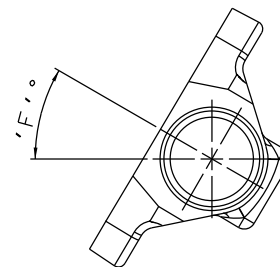

DRAIN ANGLE TOLERANCE = +/- 2°

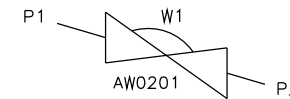

SELF DRAIN  
POSITION IN  
HORIZONTAL  
ORIENTATION

The information on this sheet is Private and Confidential and is the property of Crane Process Flow Technologies Limited and must not be published directly or indirectly in any manner whatsoever without the written permission of the Company and must not be used in any way detrimental to their interests.  
© Crane Process Flow Technologies

**CRANE** Process Flow Technologies  
A Crane Co. Company

**Saunders**  
The Science Inside

Title  
SCHEDULE OF LEADING DIMENSIONS FOR 2-WAY  
MKIII FORGED BODY WITH BUTT WELD OD TUBE ENDS.  
COMPLIANT WITH ASME BPE STANDARD.

Drawn RI	Date 02.11.11	UNCONTROLLED IN HARD COPY FORMAT	
Checked RND	Date 03.10.12		
First Angle Projection Method E	DO NOT SCALE	Drawing No. WEB-001	Issue. 2

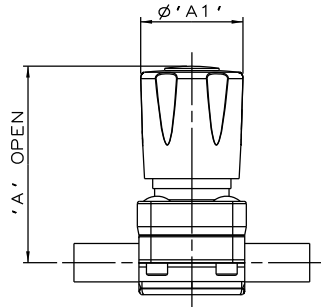

PURE PERFORMANCE BONNET ASSEMBLY

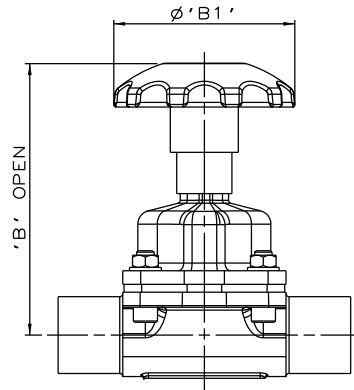

SS NON SEALED BONNET ASSEMBLY

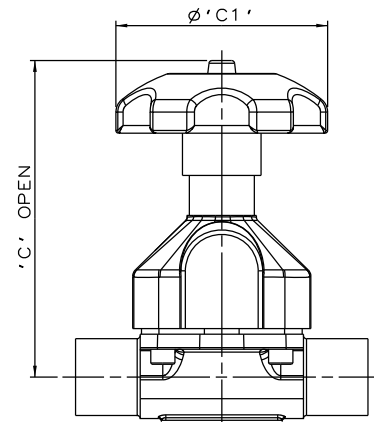

PES BONNET ASSEMBLY

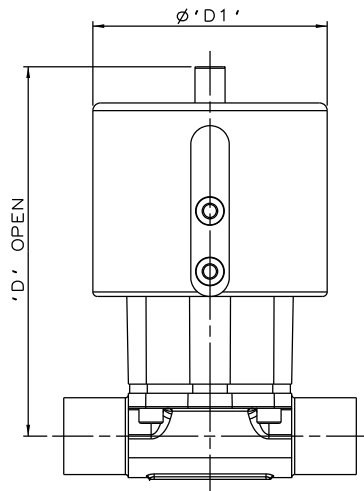

EC ACTUATOR (ALL MODES)

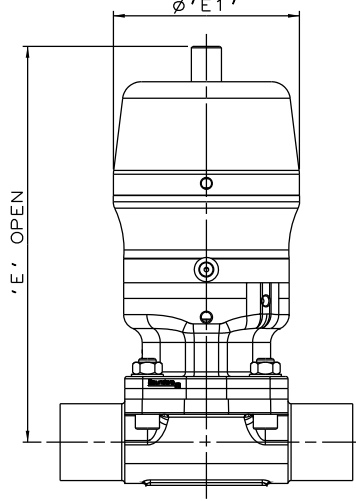

\*S360 ACTUATOR

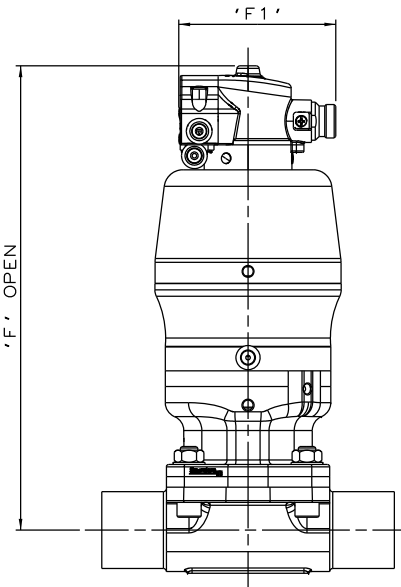

\*S360 ACTUATOR WITH M-VUE SENSOR

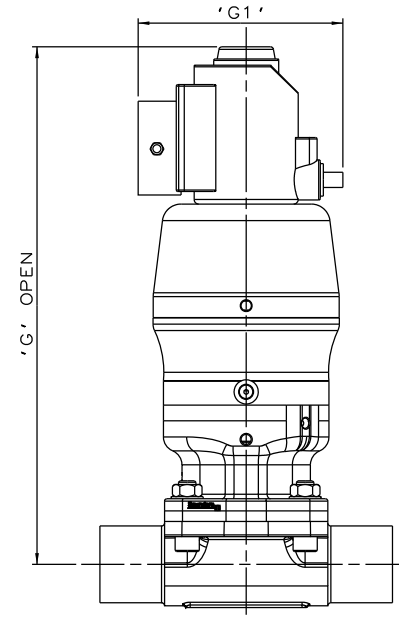

\*S360 ACTUATOR WITH I-VUE SENSOR

The information on this sheet is Private and Confidential and is the property of Crane Process Flow Technologies Limited and must not be published directly or indirectly in any manner whatsoever without the written permission of the Company and must not be used in any way detrimental to their interests.  
 © Crane Process Flow Technologies

**CRANE** Process Flow Technologies  
 A Crane Co. Company

**Saunders**  
 The Science Inside

\* DIMENSIONS SHOW MAXIMUM ENVELOPE FOR ALL MODES

VALVE SIZE	A		A1		B		B1		C		C1		D		D1		E		E1		F		F1		G		G1		
	mm	inch	mm	inch	mm	inch	mm	inch	mm	inch	mm	inch	mm	inch	mm	inch	mm	inch	mm	inch	mm	inch	mm	inch	mm	inch	mm	inch	
DN8	0.25	65.0	2.56	34.0	1.34	N/A	N/A	N/A	N/A	N/A	N/A	N/A	N/A	87.6	3.45	58.0	2.28	88.6	3.49	55.0	2.18	153.6	6.05	103.8	4.09	187.6	7.39	136.0	5.35
DN15	0.50	N/A	N/A	N/A	N/A	84.4	3.32	62.0	2.44	107.4	4.23	62.0	2.44	111.4	4.39	70.0	2.75	135.4	5.33	67.5	2.66	177.7	7.00	103.8	4.09	231.4	9.11	136.0	5.35
DN20	0.75	N/A	N/A	N/A	N/A	88.0	3.46	62.0	2.44	114.0	4.49	62.0	2.44	157.0	6.18	103.0	4.05	164.0	6.46	98.0	3.87	225.0	8.86	103.8	4.09	260.0	10.24	136.0	5.35
DN25	1.00	N/A	N/A	N/A	N/A	109.7	4.32	80.0	3.15	143.7	5.66	80.0	3.15	163.7	6.44	103.0	4.05	171.7	6.76	98.0	3.87	232.7	9.16	103.8	4.09	268.7	10.58	136.0	5.35
DN40	1.50	N/A	N/A	N/A	N/A	158.0	6.22	120.0	4.72	199.0	7.83	140.0	5.51	225.0	8.86	155.0	6.10	224.0	8.82	123.0	4.84	275.0	10.83	103.8	4.09	311.0	12.24	136.0	5.35
DN50	2.00	N/A	N/A	N/A	N/A	180.4	7.10	120.0	4.72	209.4	8.24	140.0	5.51	244.4	9.62	155.0	6.10	267.4	10.53	150.0	5.92	315.4	12.42	103.8	4.09	351.4	13.83	136.0	5.35
DN65	2.50	N/A	N/A	N/A	N/A	233.5	9.19	170.0	6.69	226.5	8.92	140.0	5.51	N/A	N/A	N/A	N/A	334.5	13.17	186.0	7.32	N/A	N/A	N/A	N/A	414.5	16.32	136.0	5.35
DN80	3.00	N/A	N/A	N/A	N/A	259.0	10.20	230.0	9.06	299.0	11.77	250.0	9.84	N/A	N/A	N/A	N/A	407.0	16.02	236.0	9.29	N/A	N/A	N/A	N/A	480.0	18.90	136.0	5.35

Title  
 SCHEDULE OF LEADING DIMENSIONS FOR 2-WAY MKIII FORGED BODY WITH BUTT WELD OD TUBE ENDS. COMPLIANT WITH ASME BPE STANDARD. FITTED WITH TOPWORKS OPTIONS

Drawn RI Date 22.02.16 UNCONTROLLED IN HARD COPY FORMAT  
 Checked RND Date 22.02.16

First Angle Projection DO NOT SCALE Drawing No. WEB-001-ASSY Issue. 1