

UNI-CHEK[®]

brands you trust.



UNI-CHEK[®] - High Performance Check Valves

CRANE[®]

Energy Flow Solutions

www.craneenergy.com

High Performance

Valves for Backflow Prevention

In almost every piping system, there is a need for backflow prevention. Most piping systems utilize pumps or compressors to generate needed pressure for movement of line fluids or gases. When rotating equipment stops, flow reversal or backflow occurs. Check valves are used to stop backflow and protect rotating equipment or other mechanical devices from the sudden backflow surges that may occur.

To satisfy your needs, specify Crane Valves—the worldwide leader of valves manufactured for the prevention of backflow.

Why Wafer Check Valves?

Wafer check valves are preferred because of their compactness, ease of installation and lower initial costs when compared to traditional flanged swing checks. These key reasons make Uni-Chek® a popular choice for systems designers. There are additional benefits, such as lower costs for shipping, storage and maintenance.

Temperature Ratings

Seal	Max. Temperature	
Metal/Stainless Steel	450°F	(230°C)*
Viton	400°F	(204°C)
Nitrile	250°F	(121°C)
EPDM	300°F	(150°C)
Neoprene	210°F	(100°C)
PTFE	450°F	(230°C)
Aflas	400°F	(204°C)

*Max temperature due to internal components.

CV and Opening Pressure

Valve Size		Opening Pressure Differential				
in	(mm)	CV	in WC	(mmWC)	psi	Bars
2	(50)	62	5.95	(151)	0.215	(0.015)
2½	(65)	109	4.50	(114)	0.163	(0.011)
3	(80)	166	3.76	(95)	0.136	(0.009)
4	(100)	318	3.18	(81)	0.115	(0.008)
5	(125)	471	2.58	(65)	0.093	(0.006)
6	(150)	720	2.12	(54)	0.077	(0.005)
8	(200)	1384	2.34	(59)	0.085	(0.006)
10	(250)	2298	2.25	(57)	0.081	(0.006)
12	(300)	4153	2.00	(51)	0.072	(0.005)
14	(350)	4984	1.60	(41)	0.058	(0.004)
16	(400)	8307	1.00	(25)	0.036	(0.002)
18	(450)	11906	0.95	(24)	0.034	(0.002)
20	(500)	16059	0.90	(23)	0.032	(0.002)
24	(600)	22705	0.82	(21)	0.030	(0.002)
30	(750)	47071	0.65	(17)	0.023	(0.002)
36	(900)	53993	0.60	(15)	0.020	(0.001)

Features and Benefits

Users find the single disc Uni-Chek® valves attractive because they provide unobstructed flow paths, are spring-assisted and less expensive than the traditional bolted cap swing check valves. In addition, they have pressure drop comparable to swing check valves. The Crane Uni-Chek® offers these features and benefits:

- Market Needs—available in sizes 2" (50mm) through 36" (900mm), and pressure classes to meet ASME, BS, DIN, AS, JIS and ISO standards.
- Compactness—enabling installation in restricted spaces not possible with conventional swing check valves.
- Lightweight—making them easier to handle and install, with less weight to support, eliminating expensive support systems.
- Variety of Materials—versatility for many services satisfies more application needs.
- Installation—wafer design bolts between flanges using one set of studs. Saves time and installation cost.
- Lower Cost—10% to 20% the weight of conventional swing checks saves money in initial cost, with minimum maintenance design.
- Single Disc-Spring Closure—provides unobstructed flow, bubble-tight O-ring seal, with good dynamic response to reduce damaging water hammer.
- Versatility—providing optional features, including external shaft with counterweight or backflush lever, position indicator, limit switches and external springs.

Note: Uni-Chek® valves are not intended for use in reciprocating compressor service.

Pressure Loss (Horizontal Flow)

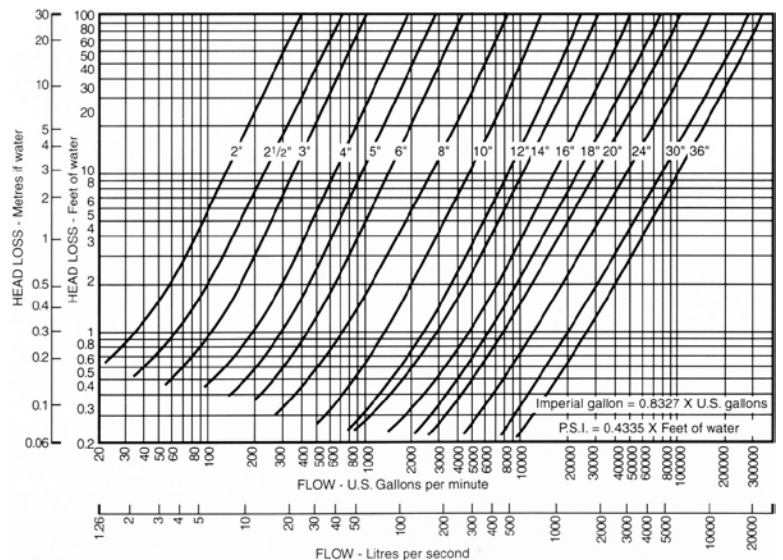

Dimensional Information

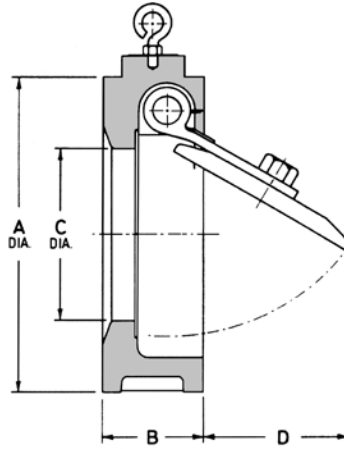

ASME Class 125

size		A		B		C		D		Weight	
in	mm	in	mm	in	mm	in	mm	in	mm	lbs.	kg.
2"	50	4 ¹ / ₈	105	1 ³ / ₄	45	1 ⁵ / ₁₆	33	1 ¹ / ₈	29	3.7	1.7
2 ¹ / ₂ "	65	4 ⁷ / ₈	124	1 ⁷ / ₈	48	1 ¹¹ / ₁₆	43	1 ³ / ₁₆	30	5	2.3
3"	80	5 ³ / ₈	137	2	51	2 ¹ / ₁₆	52	2 ³ / ₁₆	56	6.6	3
4"	100	6 ⁷ / ₈	175	2 ¹ / ₄	57	3	76	2 ¹⁵ / ₁₆	75	11	5
5"	125	7 ³ / ₄	197	2 ¹ / ₂	64	3 ³ / ₄	95	3 ³ / ₄	95	16	7.3
6"	150	8 ³ / ₄	222	2 ³ / ₄	70	4 ³ / ₄	121	4 ¹ / ₂	114	20	9
8"	200	11	279	2 ⁷ / ₈	73	6 ⁷ / ₁₆	164	6 ¹ / ₈	156	32	14.4
10"	250	13 ³ / ₈	340	3 ¹ / ₈	79	7 ⁵ / ₈	194	7 ⁵ / ₈	187	52	23.4
12"	300	16 ¹ / ₈	410	3 ³ / ₈	86	9 ¹ / ₂	241	8 ³ / ₄	222	77	35
14"	350	17 ³ / ₄	451	4 ¹ / ₄	108	10 ¹ / ₂	267	9	229	154	70
16"	400	20 ¹ / ₄	514	4 ¹ / ₄	108	12 ¹ / ₂	318	9 ³ / ₄	248	170	77
18"	450	21 ⁵ / ₈	549	4 ¹ / ₄	108	14	356	11 ³ / ₄	299	203	92
20"	500	23 ³ / ₈	606	5 ¹ / ₂	140	15 ¹ / ₄	387	12 ³ / ₄	324	298	135
24"	600	28 ³ / ₄	718	6	152	19	483	15 ¹ / ₄	387	452	205
30"	750	34 ¹ / ₄	883	6	152	23	584	20 ³ / ₄	527	—	—
36"	900	41 ¹ / ₄	1048	6	152	29	737	25	635	—	—

ASME Class 150

size		A		B		B*		C		D		Weight	
in	mm	in	mm	in	mm	in	mm	in	mm	in	mm	lbs.	kg.
2"	50	4 ¹ / ₈	105	2 ⁵ / ₈	60	1 ³ / ₄	45	1 ⁵ / ₁₆	33	1 ¹ / ₂	13	5.5	2.5
2 ¹ / ₂ "	65	4 ⁷ / ₈	124	—	—	1 ⁷ / ₈	48	1 ¹¹ / ₁₆	43	—	—	—	—
3"	80	5 ³ / ₈	137	2 ⁷ / ₈	73	2	51	2 ¹ / ₁₆	52	1 ⁵ / ₁₆	34	10	4.5
4"	100	6 ⁷ / ₈	175	2 ⁷ / ₈	73	2 ¹ / ₄	57	3	76	2 ⁵ / ₁₆	59	16	7
5"	125	7 ³ / ₄	197	—	—	2 ¹ / ₂	64	3 ³ / ₄	95	—	—	—	—
6"	150	8 ³ / ₄	222	3 ⁷ / ₈	98	2 ³ / ₄	70	4 ¹ / ₄	121	3 ³ / ₈	86	31	14
8"	200	11	279	5	127	2 ⁷ / ₈	73	6 ⁷ / ₁₆	164	4	102	49	22
10"	250	13 ³ / ₈	340	5 ¹ / ₄	146	3 ¹ / ₈	79	7 ⁵ / ₈	194	4 ¹ / ₄	121	82	37
12"	300	16 ¹ / ₈	410	7 ¹ / ₈	181	3 ³ / ₈	86	9 ¹ / ₂	241	5	127	124	56
14"	350	17 ³ / ₄	451	7 ¹ / ₄	184	4 ¹ / ₄	108	10 ¹ / ₂	267	6	152	176	80
16"	400	20 ¹ / ₄	514	7 ¹ / ₂	191	4 ¹ / ₄	108	12 ¹ / ₂	318	6 ¹ / ₂	165	220	100
18"	450	21 ⁵ / ₈	549	8	203	4 ¹ / ₄	108	14	356	8	203	242	110
20"	500	23 ³ / ₈	606	8 ⁵ / ₈	219	5 ¹ / ₂	140	15 ¹ / ₄	387	9 ⁵ / ₈	245	372	169
24"	600	28 ³ / ₄	718	8 ³ / ₄	222	6	152	19	483	12 ¹ / ₂	318	584	265
30"	750	34 ¹ / ₄	883	—	—	6	152	23	584	—	—	—	—
36"	900	41 ¹ / ₄	1048	—	—	6	152	29	737	—	—	—	—

* Optional for short pattern valve, S

AS Table E (BS Table E)

size		A		B		C		D		Weight	
in	mm	in	mm	in	mm	in	mm	in	mm	lbs.	kg.
2"	50	3 ⁷ / ₈	98	1 ³ / ₄	45	1 ⁵ / ₁₆	33	1 ¹ / ₈	29	3.7	1.7
2 ¹ / ₂ "	65	4 ³ / ₈	111	1 ⁷ / ₈	48	1 ¹¹ / ₁₆	43	1 ¹ / ₈	29	5	2.3
3"	80	5 ¹ / ₈	130	2	51	2 ¹ / ₁₆	52	2 ³ / ₁₆	56	6.6	3
4"	100	6 ³ / ₈	162	2 ¹ / ₄	57	3	76	2 ¹⁵ / ₁₆	75	11	5
5"	125	7 ⁵ / ₈	194	2 ¹ / ₂	64	3 ³ / ₄	95	3 ³ / ₄	95	16	7.3
6"	150	8 ¹ / ₂	216	2 ³ / ₄	70	4 ³ / ₄	121	4 ¹ / ₂	114	20	9
8"	200	10 ³ / ₄	273	2 ⁷ / ₈	73	6 ⁷ / ₁₆	164	6 ¹ / ₈	156	32	14.4
10"	250	13 ¹ / ₄	337	3 ¹ / ₈	79	7 ⁵ / ₈	194	7 ⁵ / ₈	188	52	23.4
12"	300	15 ¹ / ₈	384	3 ³ / ₈	86	9 ¹ / ₂	241	8 ³ / ₄	222	77	35
14"	350	17 ⁵ / ₈	448	4 ¹ / ₄	108	10 ¹ / ₂	267	9	229	154	70
16"	400	19 ⁵ / ₈	498	4 ¹ / ₄	108	12 ¹ / ₂	318	9 ³ / ₄	248	170	77
18"	450	22 ¹ / ₈	562	4 ¹ / ₄	108	14	356	11 ³ / ₄	299	203	92
20"	500	24 ³ / ₈	619	5 ¹ / ₂	140	15 ¹ / ₄	387	12 ³ / ₄	324	298	135
24"	600	28 ⁵ / ₈	727	6	152	19	483	15 ¹ / ₄	387	452	205
30"	750	32 ¹ / ₄	895	6	152	23	584	20 ³ / ₄	527	—	—
36"	900	41 ³ / ₄	1060	6	152	29	737	25	635	—	—

ASME Class 300

size		A		B		B*		C		D		Weight	
in	mm	in	mm	in	mm	in	mm	in	mm	in	mm	lbs.	kg.
2"	50	4 ³ / ₈	111	2 ⁵ / ₈	60	1 ³ / ₄	45	1 ⁵ / ₁₆	33	1 ¹ / ₂	13	6.7	3
2 ¹ / ₂ "	65	—	—	—	—	1 ⁷ / ₈	48	1 ¹¹ / ₁₆	43	—	—	—	—
3"	80	5 ⁵ / ₈	149	2 ⁷ / ₈	73	2	51	2 ¹ / ₁₆	52	1 ⁵ / ₁₆	34	13	5.8
4"	100	7 ¹ / ₈	181	2 ⁷ / ₈	73	2 ¹ / ₄	57	3	76	2 ⁵ / ₁₆	59	17	7.5
5"	125	—	—	—	—	2 ¹ / ₂	64	3 ³ / ₄	95	—	—	—	—
6"	150	9 ⁵ / ₈	251	3 ⁷ / ₈	98	2 ³ / ₄	70	4 ¹ / ₄	121	3 ³ / ₈	86	36	16.2
8"	200	12 ¹ / ₈	308	5	127	2 ⁷ / ₈	73	6 ⁷ / ₁₆	164	4	102	53	24
10"	250	14 ¹ / ₄	362	5 ¹ / ₄	146	3 ¹ / ₈	79	7 ⁵ / ₈	194	4 ¹ / ₄	121	88	40
12"	300	16 ⁵ / ₈	422	7 ¹ / ₈	181	3 ³ / ₈	86	9 ¹ / ₂	241	5	127	143	65
14"	350	19 ¹ / ₈	486	8 ³ / ₄	222	4 ¹ / ₄	108	10 ¹ / ₂	267	4 ¹ / ₂	114	210	95
16"	400	21 ¹ / ₄	540	9 ¹ / ₈	232	4 ¹ / ₄	108	12 ¹ / ₂	318	4 ¹¹ / ₁₆	124	275	125
18"	450	23 ¹ / ₂	597	10 ³ / ₈	264	4 ¹ / ₄	108	14	356	5 ⁵ / ₈	143	304	138
20"	500	25 ³ / ₄	654	11 ¹ / ₂	292	5 ¹ / ₂	140	15 ¹ / ₄	387	6 ³ / ₄	171	462	210
24"	600	30 ¹ / ₂	775	12 ¹ / ₂	318	6	152	19	483	8 ¹ / ₄	222	754	342

* Optional for short pattern valve, S

Installation

The Uni-Chek® valve installs between two pipe flanges. The body is flangeless and is centered in line by the surrounding flange bolts. Correct selection of materials and installation will ensure trouble free operation.

Consider the following:

- Check that the pipe flange drilling complies with the valve tag specification.
- Flow direction is indicated by an arrow on the valve body or name plate.
- On horizontal installations, the valve tag should always be at the top.
- Flow should always be upward on vertical installations. (Consult factory)
- The valve reaches the fully open position when the disc contacts the inside diameter of the pipe. Care should be taken when non-standard or lined pipe is used.
- Allow a downstream length of straight pipe equal to one pipe diameter before installing other valves or pipe bends, tees etc.
- Each piping system has a unique geometry which should be evaluated whenever the liquid media velocity exceeds 8 feet/second (2.4 m/sec) through a swage or expansion (15° or greater included angle) directly upstream of the valve. A minimum of five (5) pipe diameters distance should be maintained between the valve and the pump discharge and pipe fittings (swages or expansion).
- Avoid manifolds where a pump discharges directly into another pump discharge.

Acceptable

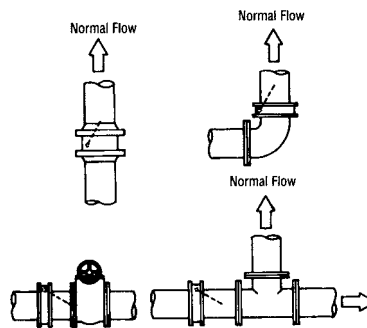

Avoid These

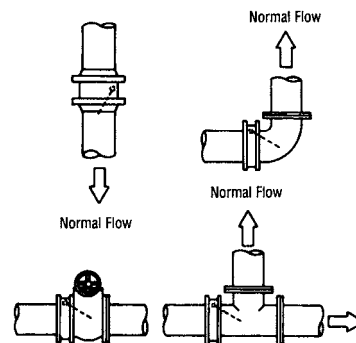

Check Valve Shaft Options

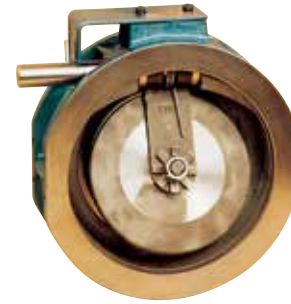

with open/shut indicator

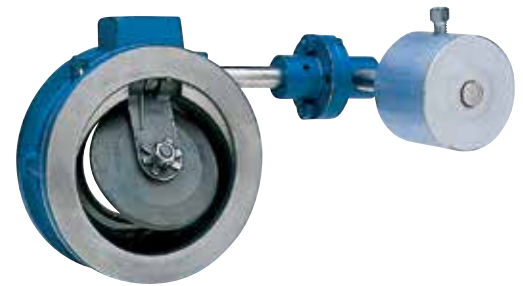

counterweight

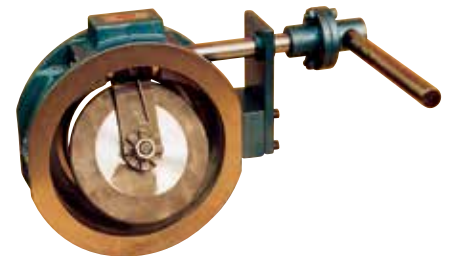

with backflush lever
(left hand option shown)



microswitch

Maintenance Precautions

Due to the low wearing of working parts and simple robust construction, the valve should not require attention for several years in normal service. However, if the valve is installed on critical applications such as sanitary isolation, it is considered prudent to make more frequent inspections. Valves subject to high frequency of operation may require spring replacement at earlier intervals. This becomes apparent when valve closure is noisy.

Ordering Information

24"	12	A	1	3	2	0	2	0
Valve Size	Pressure Class	Flange	Body Material	Disc Arm & Pin Material	Seal & Spring Material	End Connection	Shaft Option	Coating Option

Description: 24" Pressure Class 125, ASME Flange, Cast Iron Body, 316S.S. Disc Arm & Pin, Nitrile Seal, 316S.S. Spring, Flat Smooth Face, External Lever and Counterweight, Manufacturing Standard Coating.

Valve Size

Nominal valve sizes are expressed in inches or millimeters.

In inches: For use with ASME, API and BS flange standards.

In millimeters: For use with AS, DIN or JIS flange standards. (size preceded by "M" for DIN, "J" for JIS and "A" for AS with PN number shown as pressure class).

Pressure Class

Code	Class
12	125
15	150
30	300
10-16	DIN or JIS

S-Optional prefix for class 150 and 300 short pattern (S15, S30). Refer to Table B* dimensions.

Flange

Code	Flange
A	ASME
E	AS 2129 / BS 10 – Table E

Body Material

Code	Material
0	Carbon Steel to ASTM A216 Gr. WCB
1	Cast Iron to ASTM A126 Class B
2	316 Stainless Steel to ASTM A351 Gr. CF-8M
3	Low Temperature Steel to ASTM A352 Gr. LCB

Disc, Arm and Pin

Code	Material
3	316 Stainless Steel

Seal and Spring Material

Code	Material
0	Same as body material, Inconel X Spring
1	316S.S Weld Overlay, Inconel X Spring
2	Nitrile, 316S.S. Spring
3	Viton, 316S.S. Spring
4	EPDM, 316S.S. Spring
5	Neoprene, 316S.S. Spring
6	PTFE, 316S.S. Spring
7	Aflas, 316S.S. Spring

End Connection

Code	Description
0	Flat-Smooth 125 AARH
1	Serrated Per ASME B16.5

Shaft Option

Code	Description
0	No Option
1	External Lever
2	External Lever and Counterweight
3	Visual Open/Closed Indicator
4	Microswitch
5	External Spring

L-Suffix for left hand option (1L, 2L, 3L, 4L, 5L), consult factory.

CAUTION: external options may interfere with installation on some sizes, consult factory.

Coating Option

Code	Description
0	Manufacturers Standard
1	Internal Solventless Epoxy
2	External Solventless Epoxy
3	Internal and External Solventless Epoxy

UNI-CHEK®

CRANE Energy Flow Solutions®

CRANE Energy Global Headquarters
4526 Research Forest Drive, Suite 400
The Woodlands, Texas 77381 U.S.A.

Tel.: (1) 936-271-6500

Fax.: (1) 936-271-6510

www.craneenergy.com

CRANE

Energy Flow Solutions

Crane ChemPharma & Energy
146-154 Dunheved Circuit
St. Marys, NSW 2760 Australia
Tel.: (61) 2-888-90100
Fax.: (61) 3-673-3870

Belfast, Northern Ireland Operations
6 Alexander Road
Cregagh, Belfast BT6 9HJ
Tel.: (442) 890-704222
Fax.: (442) 890-401582



brands you trust.



COMPAC-NOZ®

CRANE

DUO-CHEK®



NOZ-CHEK®



STOCKHAM



UNI-CHEK®

NUCLEAR

VALVE SERVICES

EG-UC-BU-EN-L16-16-1109 (CV-603)

Crane Co., and its subsidiaries cannot accept responsibility for possible errors in catalogues, brochures, other printed materials, and website information. Crane Co. reserves the right to alter its products without notice, including products already on order provided that such alteration can be made without changes being necessary in specifications already agreed. All trademarks in this material are property of the Crane Co. or its subsidiaries. The Crane and Crane brands logotype (Aloyco®, Center Line®, Compac-Noz®, Crane®, Duo-Chek®, Flowseal®, Jenkins®, Krombach®, Noz-Chek®, Pacific Valves®, Stockham®, Triangle®, Uni-Chek®) are registered trademarks of Crane Co. All rights reserved.