



**AVID Z\* Series**  
 ATEX/IECEX Certified – Ex mb e  
 Monitor and Control Monitor

**INSTALLATION AND OPERATION MANUAL**

<b>IOM: TECHUK-92</b>		<b>Revision: 4</b>	
<b>Prepared By: C.Irwin</b>	<b>Date: 2/25/14</b>	<b>Drafting Work Order:22512</b>	<b>ECN: 13000</b>
<b>Reviewed By: T. Lee</b>	<b>Date: 8/2/18</b>	<b>Approved By: C. Irwin</b>	<b>Date: 8/2/18</b>
This IOM contains confidential information and is issued in confidence on the condition that it be returned on demand and not be copied, reproduced, disclosed to others or used in manufacture of the subject matter thereof without the written consent of Crane Co.			

## **Revision History**

### **Revision**

25 February 2014, Initial release

26 October, 2015 Rev. 1

12 April, 2016 Rev. 2

11 December, 2017 Rev. 3

1 August, 2018 Rev. 4

### **Crane Co. Locations**

**USA: +1 201 794 7650**

**Europe, Middle East & Africa: +44 (0) 1892 516277**

**Asia Pacific: +65 6869 8909**

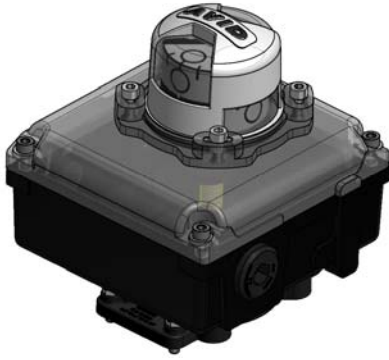

AVID Monitor

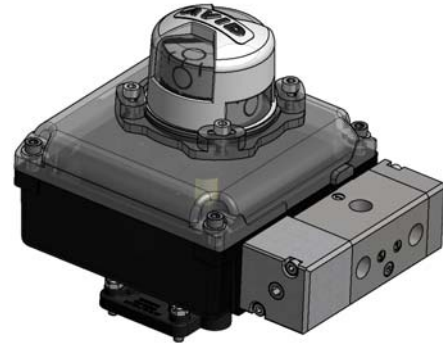

AVID Control Monitor

## 1.0 Introduction

This series of products are available in three materials, Grilamid TR90 UV (ZR), Aluminum (ZA) or Stainless Steel CF8M / 316 (ZS) and in two sizes of enclosure.

Both the Z\* series Monitors and Control Monitors provide end of travel indication by the means of either an electrical or pneumatic switches or inductive sensors mounted within the enclosure. These are activated by cams / triggers mounted on the rotary shaft. The Monitor enclosure construction comprises of a shaft passing through the enclosure housing and cover (when fitted with visual indicator). The two part enclosure has an integral gasket seal and the shaft has up to two 'O'ring seals in the bearing areas.

The Z\* Control Monitor has, located within the enclosure, up to two solenoid coils to operate / control process actuators or cylinders, either double acting or spring return, depending on the model ordered.

The Monitor has the option of up to three entries for connection to an external power source in the smaller enclosure and up to five in the larger enclosure. The Control Monitor has two or three respectively depending on whether the one or two coils are selected.

The sizes available are; M20 x 1.5p, M25 x 1.5p, 1/2"-14NPT, 3/4"-14 NPT, Pg13.5 or any other suitable thread that can maintain IP6X ingress rating.

## 2.0 Product Certification

<p><b>CE</b>          Ex mb e IIC T* Gb          Ex tb IIIC T*°C Db IP6X          Tamb -*°C TO +*°C          IECEx SIR 08.0131X</p>	<p><b>CE<sub>nnnn</sub> Ex II 2 GD</b>          Ex mb e IIC T* Gb          Ex tb IIIC T*°C Db IP6X          Tamb -*°C TO +*°C          SIRA 08 ATEX 5351X</p>
---	---

This equipment may be used in a CAT 2 or 3 Gas and Dust environments with apparatus groups covering IIA, IIB and IIC.

For the AVID Control Monitor the temperature classes are between T1 through to T5 (T100°C) at -40°C to +50°C.

For the AVID Monitor there are two temperature classes between T1 through to T5 (T100°C) -40°C to +60°C and T1 through to T6 (T85°C) -40°C to +45°C

### 3.0 Warnings.

**NOTE:** Before installation of this product, please ensure that the product and its certification is suitable for the intended application.

If the equipment is likely to come into contact with aggressive substances, then it is the responsibility of the user to take suitable precautions that prevent it from being adversely affected, thus ensuring that the type of protection provided by the equipment is not compromised.

The installer shall ensure compliance to the certificate conditions for each of the certified components installed:

- i. The terminals shall only be fitted with wires that have cross sectional area falling within the following limitations:

MK 3 Range of Terminal Strips: Rigid: 0.5mm<sup>2</sup> to 2.5mm<sup>2</sup>, Flexible: 0.5mm<sup>2</sup> to 1.5mm<sup>2</sup>

Type 262-\*\*\* Terminal strip: 0.2mm<sup>2</sup> to 4mm<sup>2</sup> (single-core, finely stranded, and stranded).

Type 07-9702-0\*2\*/\*\*\*\* Range Connecting Terminal: 0.2mm<sup>2</sup> to 2.5mm<sup>2</sup> (solid, fine-stranded and multi-stranded)

Terminal Block KL-\*-25-400: Solid/Stranded: 0.5mm<sup>2</sup> to 2.5mm<sup>2</sup>, Flexible: 0.5mm<sup>2</sup> to 1.5mm<sup>2</sup>

- ii. For MK 3 Range of Terminal Strips: Except when shown in a certificate as being internal wiring of apparatus, not more than one single or multiple strand lead shall be connected into either side of any terminal, unless multiple conductors have been joined in a suitable manner, e.g. two conductors into a single insulated crimped boot lace ferrule.
- iii. For MK 3 Range of Terminal Strips: Leads connected to the terminals shall be insulated for the appropriate voltage and this insulation shall extend to within 1mm of the metal of the terminal throat.
- iv. For MK 3 Range of Terminal Strips: All terminal screws, used and unused, shall be tightened down to between 0.4 Nm and 0.45 Nm,
- v. For MK 3 Range of Terminal Strips: MK 3/2 and MK 3/3 terminals shall be mounted in such a way as to prevent any rotation of the terminal strip during tightening or loosening of the terminal screws. All other larger terminals shall be mounted using at least two of the fixing holes to prevent rotation.
- vi. For MK 3 Range of Terminal Strips: Minimum creepage and clearance distances between the installed terminals and adjacent conductive, equipment, enclosure walls and covers shall be 5 mm, unless QB cross-connecting combs are used and are angled downwards, in which case these values are reduced to 3.2 mm in both cases.
- vii. For MK 3 Range of Terminal Strips: When QB cross-connecting combs are used with the angled black insulation inclined upwards, the maximum voltage rating at the terminal strips is unchanged, but when the comb is angled downwards the voltage rating is reduced to 175 V maximum - see above point.
- viii. For MK 3 Range of Terminal Strips: Where the prong of an insulating comb is used in a terminal way, a further single conductor of 1.0 mm<sup>2</sup> minimum cross-sectional area may be connected to the same terminal way on top of the prong.
- ix. For MK 3 Range of Terminal Strips: The inside edge of the insulation of the combs cross-connecting arm shall be in contact with the terminal molding.
- x. For MK 3 Range of Terminal Strips: The terminals shall only be installed and wired with cable in an ambient temperature of -10°C to +80°C.
- xi. For MK 3 Range of Terminal Strips: The QB cross-connecting combs are limited to the same current rating as the terminal and shall not be used with currents in excess of this value.
- xii. Type 262-\*\*\* Terminal strip: Concerning the use of accessories the instructions of the manufacturer shall be considered.
- xiii. Type 262-\*\*\* Terminal strip: When feed-through terminals with earthing-conductor terminal blocks are mounted side by side, end cover plates or adaptor plates are to be provided.

- xiv. Type 07-9702 Range Connecting Terminal: These terminals may be fixed only with the appertaining screws.
- xv. Type 07-9702 Range Connecting Terminal: If accessories are used, the instructions for installation provided by the manufacturer shall be observed.
- xvi. Type 07-9702 Range Connecting Terminal: Rated torque= max. 0.4 Nm.
- xvii. Terminal Block KL-\*-25-400: Take care at installation that the conductor insulation reaches the terminal immediately.

The maximum dust layer shall be no greater than 5 mm (T5 135°C).

**WARNING: POTENTIAL ELECTROSTATIC CHARGING HAZARD - clean only with damp cloth.**



This symbol warns the user of possible danger. Failure to heed this warning may lead to personal injury or death and/or severe damage to equipment.



This symbol identifies information about operating the equipment in a particular manner that may damage it or result in a system failure. Failure to heed this warning can lead to total failure of the equipment or any other connected equipment.



This symbol draws attention to information that is essential for understanding the operation and/or features of the equipment.

#### **4.0 Mounting Instructions.**

Required Tools: Only use spanners of the correct size or an adjustable spanner to fit hex head bolts in the mounting kit.

##### **4.1 Direct Mount.**

- 4.1.1 Select the correct actuator drive adaptor to suit the actuator pinion and insert the 11mm A/F in the correct position and press down.
- 4.1.2 Orientate the AVID Position Monitor and locate the Modmount drive coupler into the actuator drive adaptor. Press down so that the Modmount is fully seated on the actuator mounting face.
- 4.1.3 Using an 8mm A/F spanner, secure the assembly taking care not to exceed the torque specified on the bracket. See Figure 1.

##### **4.2 Namur Mount.**

- 4.2.1 Obtain a mounting kit suited for the actuator/valve, commonly available through a local Pentair distributor.
- 4.2.2 Attach the mounting bracket and coupler (if required) to the unit housing with the hardware provided. Typical actuator hardware is M5 (8mm A/F) and monitor mounting M6 (10mm A/F) or M8 (13mm A/F).
- 4.2.3 Attach the unit and mounting system to the actuator. See Figure 1.

4.2.4 Ensure axial alignment between unit shaft, coupler and actuator shaft. Failure to correctly align could result in long-term stress-related failure of unit shaft in high cycle or high torque applications.



Before stroking the actuator to the fully closed position, please ensure that the process is safe to do so.

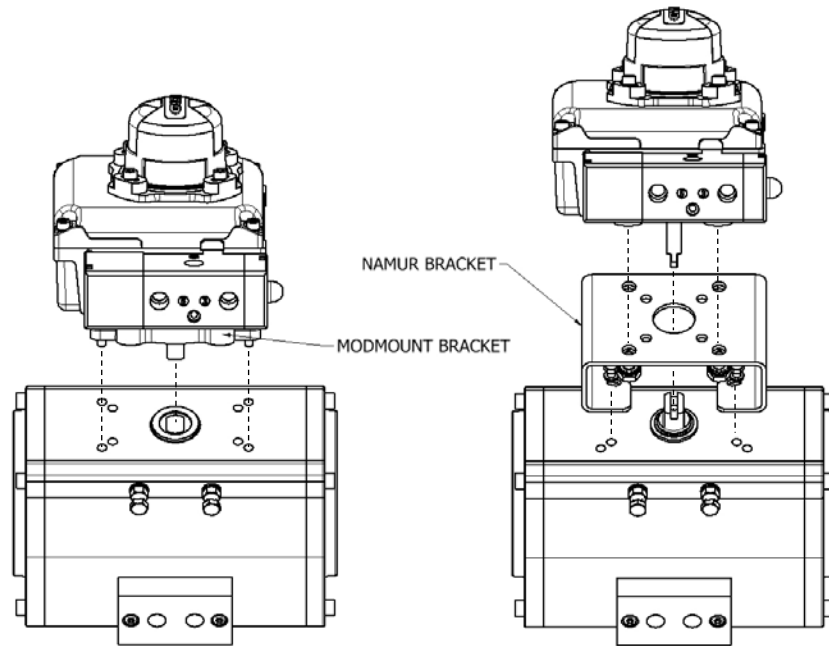

Fig 1

## 5.0 EaziFix Cam Settings.

5.1 To release the cover, loosen the cover retaining screws using a 4mm A/F Allen Key. Lift the cover and twist approx 45° and remove. See Figure 2 below.

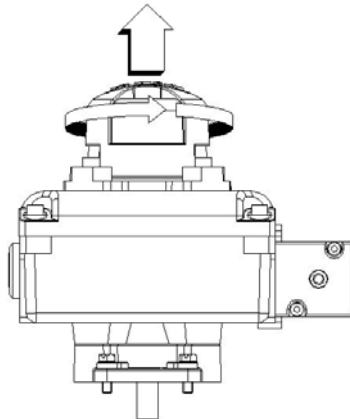

Fig 2

5.2 To set the lower switch, lift the bottom EaziFix cam and turn until the switch has activated and then release. The spring will push the EaziFix cam back onto the splined shaft.



Before stroking the actuator, please ensure that the process is safe to do so and that all hands are kept away from the moving shaft / cams.

- 5.3 Stroke the actuator to the opposite end of travel. Set the top EasiFix cam by pushing down and turning the EasiFix cam until the upper switch is activated.
- 5.4 Stroke the actuator from one end of stroke to the other several times to check the switch operation. If the switches require adjustment, repeat steps 5.2 to 5.3.

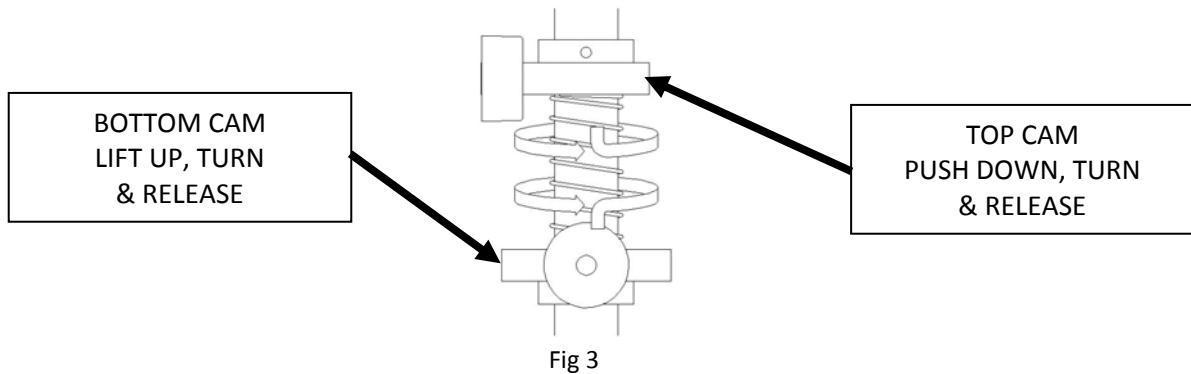

## 6.0 Field Wiring & Installation.



**WARNING:** The Z\* series should always be handled with care when the cover is removed.

**NOTE:** Before electrical installation, please read and follow the wiring diagram located inside the cover. The electrical ratings can be found on the product I.D label.

- 6.1 Field wiring must be carried out in accordance with site, local and national electrical codes / requirements. This includes special attention to earth bond to the Aluminium or Stainless Steel enclosure using the internal and external earth points provided.
- 6.2 Installation of this product shall be carried out by competent personnel in accordance with the applicable code of practice such as 60079-14.
- 6.3 The Z series housing can offer upto three conduit entries whereas the Z+ series can offer upto two entries of the following thread sizes; M20 x 1.5p, M25 x 1.5p, ½"-14 NPT or ¾"-14 NPT. The entries are detailed on the product ID label found on the product cover. Please see below the designated conduit location.

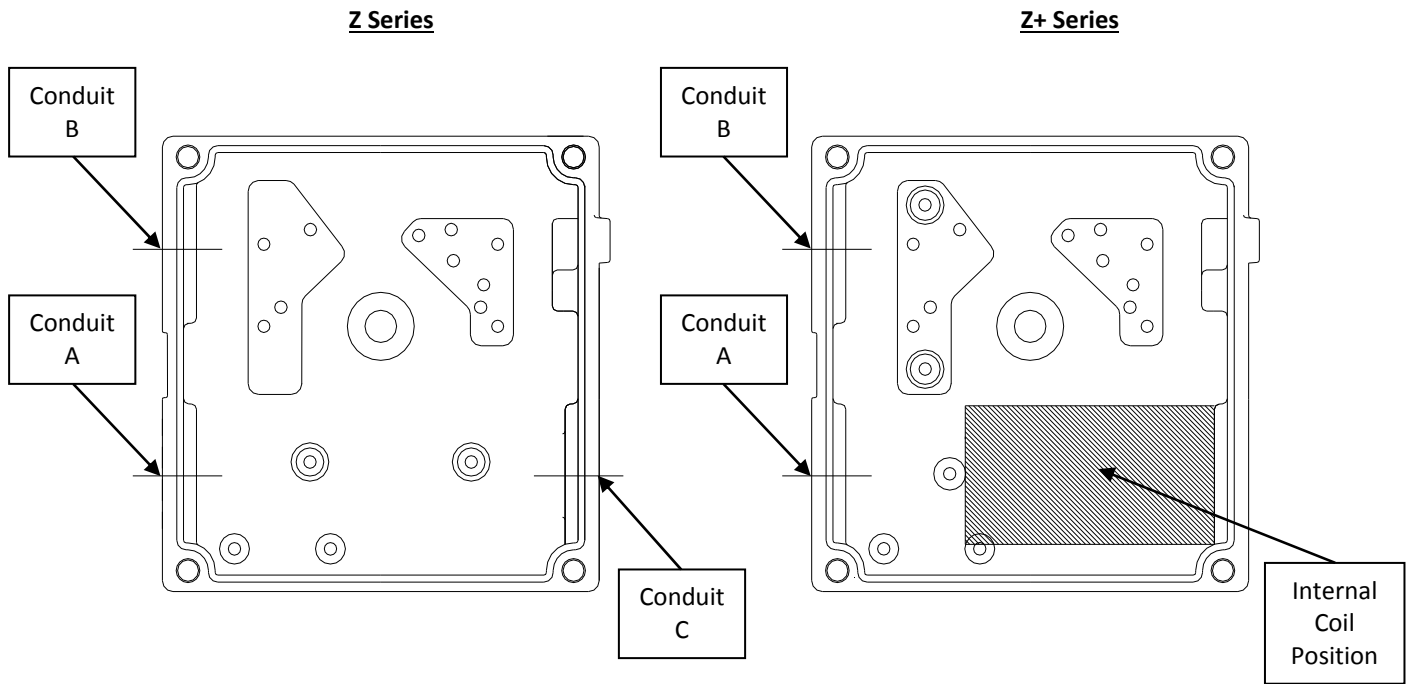

- 6.4 The certification applies to equipment without cable glands. When mounting the enclosure in the hazardous area, only suitably rated IP 66 / 67, ATEX / IECEx (dependent on scheme) certified glands must be used.
- 6.5 All unused cable entries must be plugged with a suitably rated IP 66 / 67 ATEX / IECEx (dependent on scheme) certified blanking devices.
- 6.6 Before replace the enclosure cover, ensure that both of the housing and cover sealing surfaces are clean and undamaged. Tighten the cover screws hand tight using a 4mm A/F Allen key.

**7.0 Operating and Maintenance Instructions for AVID Solenoid Valve.**

**7.1 General Description**

7.1.1 The AVID solenoid valve incorporates elastomer static seals through which a shaped spool moves and are manufactured for 3 or 5 way operation. 3 way is normally used for pilot control of the other relay valves or for the operation of single acting cylinders. 5 way is normally used to control the action of double acting cylinders. The seal spacer assembly forms individual annular chambers opposite each valve port and the grooved spool either closes or allows flow between adjacent chambers, hence the position of the spool determines which ports are open or closed.

The spool is moved by way of a manually or mechanically operated mechanism normally against a return spring. Operation may be by application or removal of a pilot air supply acting as a pilot piston. This form of control is utilized for electrical actuation where integral solenoid valves control the pilot air supply.



### 7.1.2 Optional Features.

#### No-Voltage Release (Latching)

With the coil first energized, the palm button is then manually moved and latched. The inward movement of the palm button causes the valve to shift. When the coil is de-energized, the palm button and latching mechanism are automatically tripped, allowing the valve to return to its original position. See Fig. 1

#### Manual Locking Override

Manually depress palm button and rotate clockwise for maintained condition, must manually disengage to return to original position. See Fig. 2

#### Momentary Override

Spring return momentary push type, must hold in to actuate. See Fig. 3

#### Hex Drive Maintained Override

Insert allen key in hex head screw and rotate clockwise (4-5 turns) to shift spool. Valve will stay put until hex head screw is rotated counter clockwise (4-5 turns) back to original position. See Fig. 4

#### D/C - Dual Coil Option

Five way valves are available with a coil/pilot valve on each end of the AVID valve, coil "A" and coil "B".

When coil "A" is energized the valve will shift. If coil "A" is then de-energized, the valve will remain in this position.

The valve will not return to the original state until coil "A" is de-energized and coil "B" is energized. The process is the same for coil "B".

#### NOTE - For Dual Coil Valves

The valve may be in either position upon installation. Refer to the Air Flow Diagrams and energize the appropriate coil (with air) to reset valve to the desired position.

Dual coil valves require both an electrical signal and air pressure to operate. See Air Flow Diagram for air pressure requirements.

If either or both inputs are lost the valve will remain in its current position.

**Both coils should never be energized simultaneously.**

### 7.2 Specifications

Operating Pressure: 45-120 PSIG  
Operating Media: Non Lubricated Filtered Air to 20 Microns

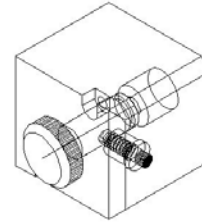

Fig. 1

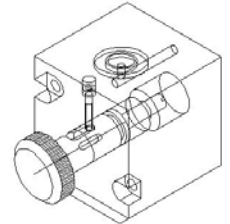

Fig. 2

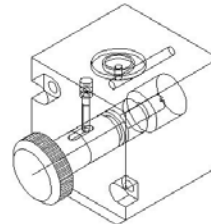

Fig. 3

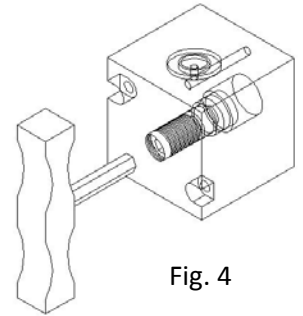
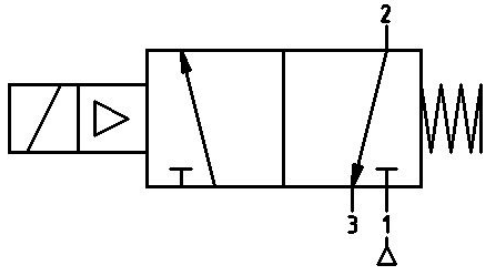
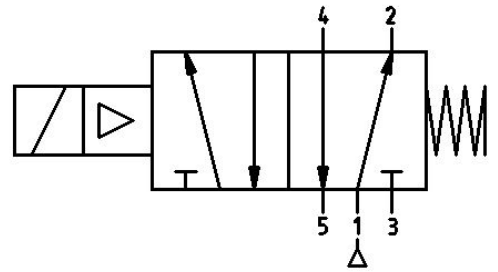

Fig. 4

7.3 Pneumatic Porting Configurations



**3/2 Spring Return Valve.**  
**Description of Operation:**  
Solenoid De-Energised -  
 Air flows from Outlet Port 2 to Exhaust Port 3.  
Solenoid Energised -  
 Air flows from Inlet Port 1 to Outlet Port 2.



**5/2 Spring Return Valve.**  
**Description of Operation:**  
Solenoid De-Energised -  
 Air flows from Inlet Port 1 to Outlet Port 2 and exhausts from Port 4 to 5.  
Solenoid Energised -  
 Air flows from Inlet Port 1 to Outlet Port 4 and exhausts from Port 2 to 3.

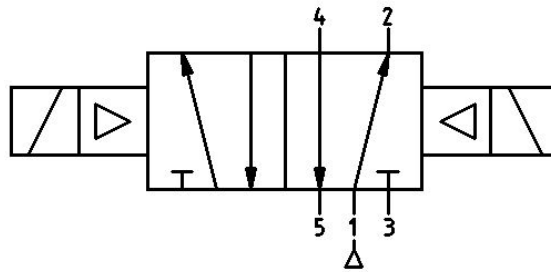

**Dual Coil Valve.**  
**Description of Operation:**  
Coil B De-Energized -  
 Air flows from Inlet Port 1 to Outlet Port 2 and exhausts from Port 4 to 5.  
Coil 'A' Energized -  
 Air flows from Inlet Port 1 to Outlet Port 4 and exhausts from Port 2 to 3.

7.4 (Air Line) Installation Considerations.

Air Mains and lines should be large enough to avoid excessive pressure loss under conditions of maximum flow.

Air lines should be installed with as few restrictions as possible if the cost of compressed air is to be kept to a minimum. Sharp turns in piping should be avoided for more efficient air flow and economical air power.

It is advisable to pitch the mains in the direction of air flow so that both gravity and air flow will carry the water to traps or water legs located at frequent intervals.

To help in preventing condensed moisture from reaching the point of usage, down pipes should never be taken directly from the bottom of air pipes or mains. Connection should be made at the top of the main and a large radius return bend used.

7.5 Air Flow.

Pipe sizes are normally determined on semi empirical lines, basis for selection being an acceptable pressure drop e.g. not more than 10% of the applied pressure. In sizing pipes, consideration should be given to likely future demands, as a system will be inefficient if the demand outgrows the supply. It is always better to over size mains as this will reduce air velocity and make water separation more effective.

## 7.6 Air Service Equipment.

The importance of proper filtration (20 Micron) and lubrication of the air supply to pneumatic equipment can never be over-emphasized as a means of decreasing friction and preventing corrosion and wear due to moisture and abrasive solids being present in the air supply.

At higher pressures than recommended, pneumatic equipment can wear excessively with no significant increase in output and compressed air is consequently wasted.

There is much to be gained, therefore, from providing pneumatic equipment with serviced air by including suitable airline filters, pressure regulators and lubricants in the installation.

## 7.7 Tubes and Fittings.

The use of copper, stainless steel, nylon or polyethylene tube is recommended for piping up air circuits and equipment. As a general rule, pipe threaded fittings should not be assembled to a specific torque because the torque required for a reliable joint varies with thread quality, port and fitting materials, sealant used, and other factors.

The suggested method of assembling pipe threaded connections is to assemble them finger tight and then wrench tighten further to a specified number of turns from finger tight.

The assembly procedure given below is for reference only, the fitting should not be over tightened for this will lead to distortion and most likely, complete valve failure.

1. Inspect port and connectors to ensure that the threads on both are free of dirt, burrs and excessive nicks.
2. Apply sealant/lubricant or Teflon tape to the male pipe threads. With any sealant tape, the first one or two threads should be left uncovered to avoid system contamination.
3. Screw the connector into the port to the finger tight position.
4. Wrench tighten the connector approximately 1 - 2 turns (to seal) from finger tight, again this is only reference – the fitting should NOT be over tightened

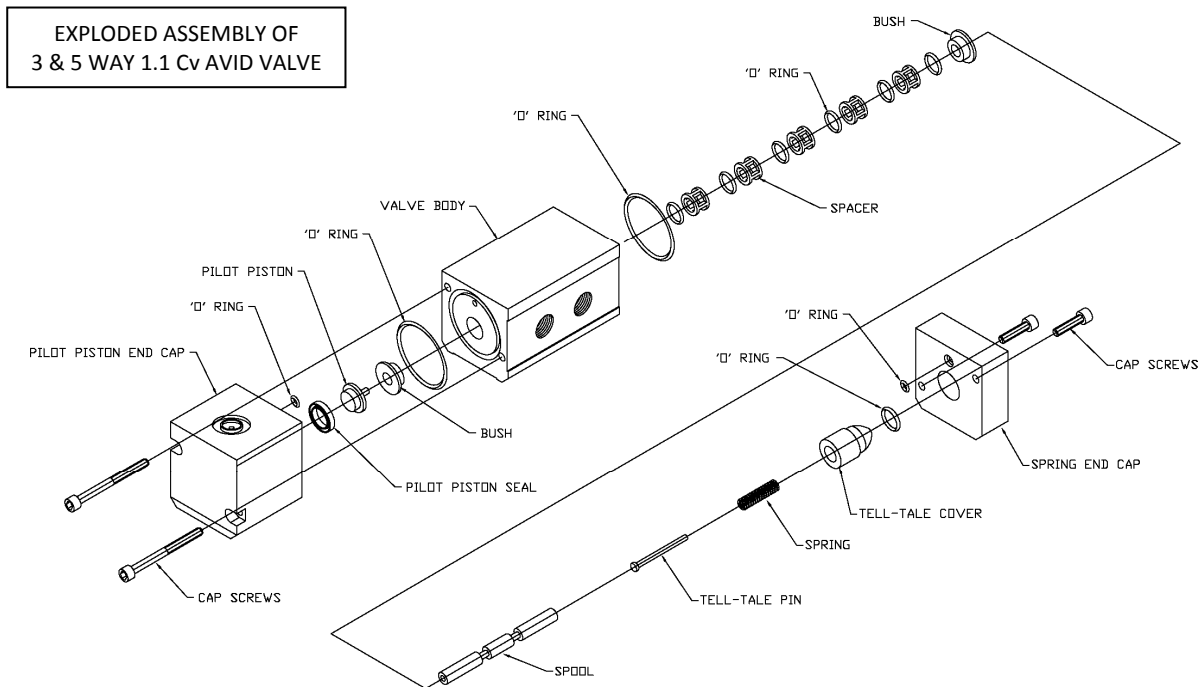

CRANE CO.

280 N. MIDLAND AVE., STE 258, SADDLE BROOK, NJ 07663 WWW.AVIDCONTROLS.COM

**8.0 Product Repair & Service.**

- 8.1 It is recommended that a periodic visual and operation evaluation is carried out of the Monitor/Control Monitor at least once a year or every 1 million cycles. If the shaft requires lubrication then a suitable (NLGI 2) rated grease such as Rocol Sapphire Lo Temp 2 should be used. Please note that if any other lubricant other than Rocol Sapphire Lo Temp 2 then is shall be compatible with the shaft 'O'ring material.
- 8.2 For Control Monitors ONLY - It is recommended that a periodic visual and operation evaluation is carried of the Control Monitor AVID solenoid valve at least once a year or every 1 million cycles. If the spool & seals require lubrication then use Molykote 55 grease.
- 8.3 Inspection of this product shall be carried out by periodically by suitably trained personnel in accordance with the applicable code of practice such as 60079-17 to ensure that it is maintained in a satisfactory condition.
- 8.4 The equipment is not intended to be repaired by the user. The repair of this equipment is to be carried out by the manufacturer, or their approved agents, in accordance with the applicable code of practice such as 60079-19.
- 8.5 The equipment contained within this product can be replaced with like for like parts / assemblies ONLY.
- 8.6 The certification of this product has been approved based on the material of construction as per the drawings listed in the schedule within this certificate. Any replacement parts that are not made in accordance to the listed drawing will invalidate the approval / certification.
- 8.7 Replacement parts must be purchased through Crane Co. or via an approved AVID distributor.

**Crane Co. Customer Satisfaction Questionnaire.**

In a continuous effort to improve our products and service to our customers, we would appreciate a small moment of your time to complete the following questions about your recent purchase;

Rating us from 1 to 10 (1 being poor and 10 excellent) please indicate your perception of our performance.  
Thank you, your feedback is essential to our improvement and success.

How Do You Rate....

		10	9	8	7	6	5	4	3	2	1
1	<b>Quality of the product?</b> Comments -										
2	<b>Use of this IOM?</b> Comments -										
3	<b>Ease of use of this product?</b> Comments -										
4	<b>Crane Co. as a manufacturer?</b> Comments -										
5	<b>Delivery leadtime?</b> Comments -										
6	<b>Condition of product received?</b> Comments -										

If you have any other comments, please indicate below;

Company :  
Customer Name :  
Position :  
Date :  
Please fax completed questionnaires to +1-201-794-0913