

 **STOCKHAM®**

brands you trust.



STOCKHAM® - Cast Steel Valves

CRANE®

Energy Flow Solutions

www.craneenergy.com

Contents

Performance in Any Application.....	4
How to Specify and Order Valves.....	4
Installation, Marking and Identification.....	5
Gate Valves.....	6
Globe Valves.....	11
Check Valves.....	16

Figure Number Index

Figure No.	Page
15-OF-U.....	8
30-OF-U.....	9
60-OF-U.....	10
15-GPF-U.....	13
30-GPF-U.....	14
60-GPF-U.....	15
15-SF-U.....	18
30-SF-U.....	19
60-SF-U.....	20

Figure Number Cross Reference

Valve Type	Class	Stockham	Jenkins
Gate	150	15-OF-U	J1009B8F
	300	30-OF-U	J1010B8F
	600	60-OF-U	J1012B8F
Globe	150	15-GPF-U	J1040B2
	300	30-GPF-U	J1042B2
	600	60-GPF-U	J1044B2
Check	150	15-SF-U	J1025B2
	300	30-SF-U	J1026B2
	600	60-SF-U	J1028B2

Performance in Any Application

In any fluid handling system, valves are the controlling element: starting or stopping flow, regulating or throttling flow, preventing backflow, or relieving and regulating pressure.

Since Stockham valves are used in a variety of applications, the following descriptions may provide a basic guideline in the selection of steel valves.

Gate Valves

Gate valves serve as efficient stop valves with flow in either direction. They are commonly used where a minimum pressure drop is important. Throttling is not recommended because partially open gate valves exhibit flow characteristics not conducive to accurate and consistent flow control. Also, the valves may be damaged by the high velocity across the seats. They function best fully open or fully closed.

Gear Actuators recommended for Gate valves:

Class 150: sizes above 10"

Class 300: sizes above 8"

Class 600: sizes above 6"

Globe Valves

Globe valves are ideal for throttling service. Their flow characteristics permit accurate and repeatable flow control. However, caution must be exercised to avoid extremely close throttling when pressure drop exceeds 20%. This creates excessive noise, vibration and possible damage to valves and piping.

Gear Actuators recommended for Globe valves:

Class 150: sizes above 6"

Class 300: sizes above 6"

Class 600: sizes above 4"

Swing Check Valves

Swing Check valves prevent reversal of flow through pipe lines. Most Stockham swing check valves can be installed in horizontal or vertical, upward flow, piping but we do not recommend that the valves be installed in vertical piping. They offer low resistance to flow and are particularly suited to low velocity service. The proper sizing of Check valves is critical to performance. Please refer to Page 17 or consult Stockham with flow conditions of your piping system for assistance in sizing.

How to Specify and Order the Correct Valves

Care should be taken to select the most suitable steel valve for your service(s). Exact specification of each valve should be made to avoid ambiguity when requesting quotations or ordering the product.

Size

Nominal size of the pipeline into which the valve will be placed must be determined. Comprehensive data on flow characteristics and pipe properties are available upon request from Stockham.

Pressure/Temperature Ratings

Please pay careful attention that the PRESSURE/TEMPERATURE RATINGS shown on page 21 are in keeping with the requirements of the service.

Valve Material

The following facts should be considered in determining the correct valve material:

- The media to be controlled
- The temperature of the media
- The possible extraordinary stresses affecting the valve
- Safety standards and/or piping codes

Valve End Connections

Considerations as to pipeline integrity, future maintenance, corrosion factors, field assembly, weight and safety should be given in determining the method of connecting the valve in the pipeline.

CAUTION: When servicing, disassembling or disposing of valves containing asbestos gaskets or packing, avoid breathing dust or fibers from these parts. Disposal of asbestos and asbestos-related products should comply with local, state and federal laws and regulations.

Installation, Marking and Identification

When purchasing valves, reference should also be made to MSS SP-92 “Valve Users Guide.” Inquiries relating specifically to Stockham products may be referred to our factory or customer service department.

Marking and identification of Stockham steel valves conforms to ASME B16.34 and MSS SP-25.

It is important to properly identify valves in service to allow for the ordering of replacement parts or address questions or concerns relating to our products. Body markings and information shown on the identification plate helps to properly identify valves, allowing timely and accurate responses to such inquiries.

Integrally cast body marking data includes the following information and helps to provide traceability:

- Stockham name
- Pressure class
- Valve size
- “Steel” symbol for the grade of material (i.e., WCB for carbon steel)
- Heat number – on body and bonnet (cast or stamped)
- Individual serialization

The body markings are supplemented by an identification plate which, depending on valve type and size, is mounted in the most practicable position. Tag location for gate and globe valves is typically on the valve yoke or body/bonnet flange. Check valve tags are typically mounted on the rim of the cap.

Identification plates bear the following information:

- Catalog number
- Valve size
- Body material
- Disc material
- Stem material
- Seat and trim material
- Pressure and temperature rating

I.D. Tag Marking Information

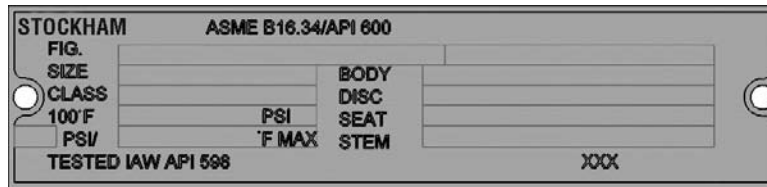

Product Marking

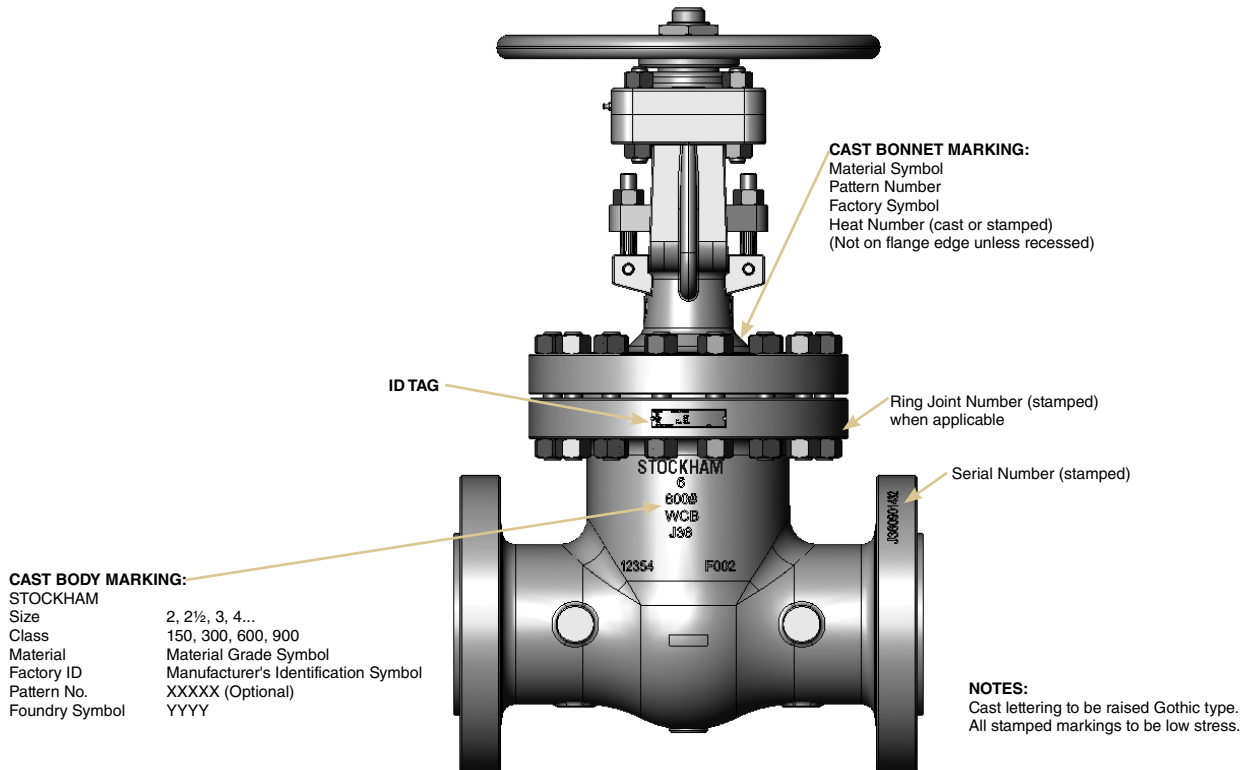

General Information Class 150, 300 and 600 Gate Valves

Features

Flexible Wedge

- Compensates for deformation of body due to pipe stresses
- Will not stick when valve is closed hot and allowed to cool

Welded-in Seat Ring

- Seat ring is seal welded to eliminate leak path

Standards

These valves comply with the applicable requirements of the following standards:

- API 600
- API 598
- ASME B16.34
- ASME B16.10
- ASME B16.5

Inspection Policy for Stockham Valves

Every Stockham cast steel valve is subjected to a 100% pressure test according to API 598 requirements. Manufacturer's material test reports and Inspection and Test Certifications are available upon request. Some of the additional inspections and tests performed are:

- Random Radiograph Inspection of Body and Bonnet Castings to ASME B16.34 Appendix B
- Random Chemical Composition and Mechanical Properties Verification of Fasteners to ASTM A-193/A-194
- Liquid Penetrant Inspection of Seat Rings
- Visual Inspection of Casting to MSS SP-55 and MSS SP-112
- Receiving, In-Process, and Final Dimensional Inspections to Relevant Valve Standards

Other inspections or tests can be performed or evaluation criteria applied when specified by the customer.

Notes

- Standard material is ASTM A216 Grade WCB
- Standard trim is API #8 (13% Cr to hardface) which is suitable for a wide range of applications

Typical Bolted Bonnet Gate Features

Stockham gate valves offer the ultimate in dependable service for steam, air, gas, oil, oil vapor, and high pressure installations. All have straight-through ports to assure minimum turbulence, erosion, and resistance to flow. They are available in a wide variety of trims.

1. **Body:** Body is cast to provide liberal strength to meet operating conditions and to permit unobstructed flow. Turbulence, erosion and pressure drop are minimized.
Flanged End - Stockham cast steel gate valves are available in flanged end. All flanged end valves are designed to conform to ASME B16.5 and ASME B16.34 standards.
2. **Integral Yoke & Bonnet:** Some designs incorporate a two-piece bonnet and yoke. All bonnet assemblies are cast and finished to the same exacting tolerances as the bodies for accurate alignment of stems and ease of sealing. Bonnet joint varies from flat face gasket-joint to ring-type bonnet joint, depending on class.
3. **Seat Rings:** Seat rings are seal welded to eliminate leak path behind rings and for long, trouble-free service. The surfaces are precisely ground to fit accurately with the disc.
4. **Disc:** One piece flexible disc provides accurate alignment of mating seating surfaces so the valve can absorb piping strains without leakage. Also, it avoids any tendency to stick in the seated position.
5. **Stem:** The tee-head disc-stem connection prevents lateral strain on the stem for smooth, easy operation. Accurately cut threads engage the yoke sleeve for positive control of disc position.
6. **Yoke Sleeve**
7. **Handwheel Nut**
8. **Yoke Sleeve Retaining Nut**
9. **Packing:** Packing contains corrosion inhibitor to avoid stem pitting. Stuffing box is deep, assuring long packing life.
10. **Gland:** Gland is a two-piece ball-type which exerts even pressure on the packing without binding the stem.
11. **Gland Flange**
12. **Gland Eye Bolts:** Eyebolts swing aside for ease in repacking the stuffing box.
13. **Gland Eye Bolt Nuts**
14. **Bonnet Gasket**
15. **Bonnet Studs:** Number is dependent on valve size and class.
16. **Bonnet Nuts:** Number is dependent on valve size and class.
17. **Gland Eyebolt Pins**
18. **Bonnet Bushing**
19. **Handwheel:** Stockham gate valves can also be supplied with gear or motor operators.
20. **Hydraulic Grease Fitting:** Hydraulic grease fitting provides for lubrication of yoke sleeve bearing surfaces (not shown).

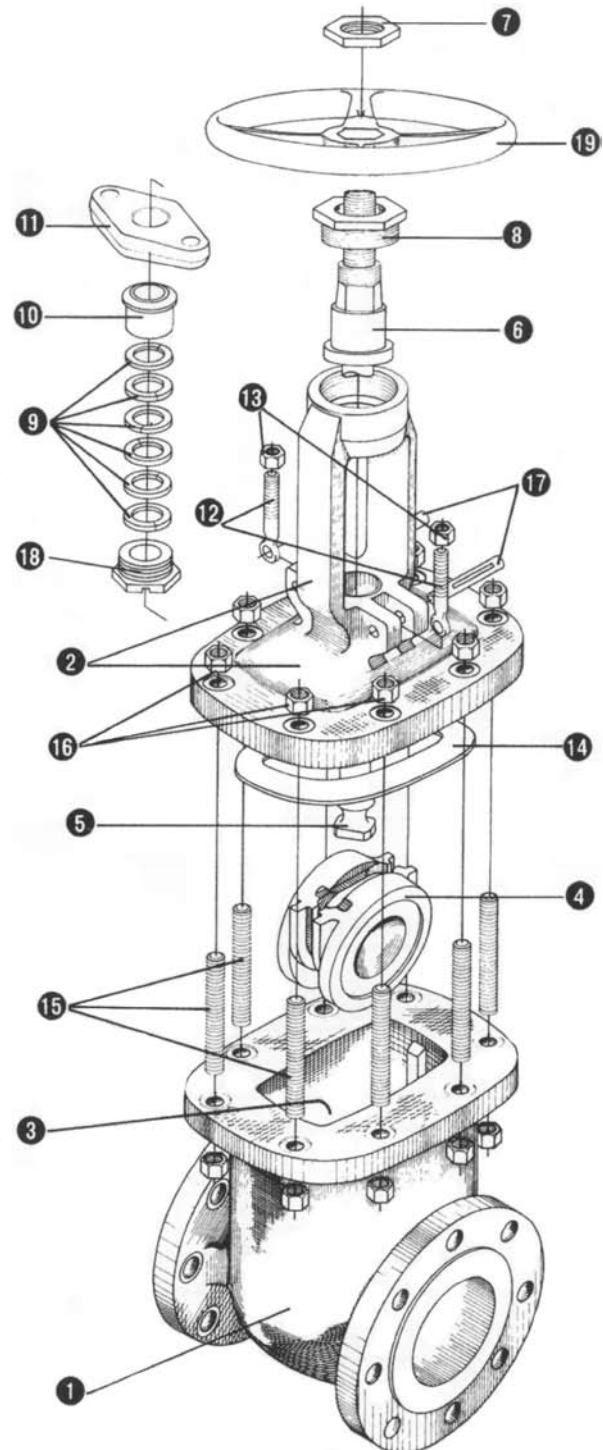

NOTE: Stockham recommends the use of gear assistance for certain multi-turn valves for optimal functional performance in larger sizes and high flow-rate applications. Please refer to the note on specific product pages.

Figure 15-OF-U

Class 150 • Outside Screw & Yoke • Flexible Wedge Disc

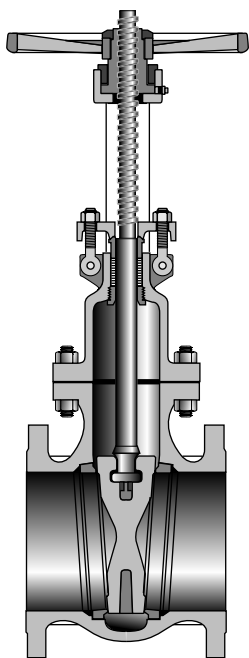

Figure 15-OF-U
Flanged

Size Range:
2 through 24 inches
(50 - 600 mm)

Pressure Temperature Rating
Carbon Steel
ASTM A216 Grade WCB
285 psi @ -20°F to 100°F
(20 bar @ -28°C to 37°C)

Material of Construction*

Description	Material
Body	WCB
Bonnet	WCB
Seat Rings	Hardfaced
Disc	CA-15 or 13% CR Overlay
Stem	410 SS
Packing	Graphite
Bonnet Gasket	Stainless Steel w/Graphite
Back Seat	410 SS
Yoke Sleeve	D2 Ni-Resist
Retaining Nut	Malleable or Steel
Gland	Steel
Gland Flange	Steel
Eye Bolt	Steel
Eye Bolt Nuts	Steel
Pins	Steel
Bonnet Studs	A193 Gr. B7
Bonnet Nuts	A194 Gr. 2H
Handwheel	Malleable, Ductile or Steel
Handwheel Nut	Ductile or Steel
I.D. Tags	SS
I.D. Pins	Steel
Spacer	Steel
Grease Fittings	Steel

Industry Standards

Steel Valves	ASME B16.34
Face-to-Face	ASME B16.10
Flange Dimensions	ASME B16.5
Basic Design	API 600
Testing	API 598

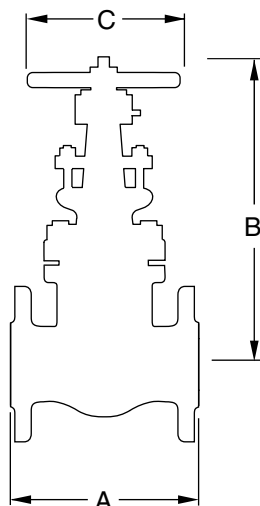

Dimensions and Weights

Inches (millimeters) - pounds (kilograms)

Valves	2 (50)	2 ½ (65)	3 (80)	4 (100)	6 (150)	8 (200)	10 (250)	12 (300)	14 (350)	16 (400)	18 (450)	20 (500)	24 (600)
A	7.00 (178)	7.50 (191)	8.00 (203)	9.00 (229)	10.50 (267)	11.50 (292)	13.00 (330)	14.00 (356)	15.00 (381)	16.00 (406)	17.00 (432)	18.00 (457)	20.00 (508)
B (Open)	16 (390)	17 (432)	20 (500)	23 (584)	31 (787)	39 (990)	48 (1160)	55 (1397)	61 (1549)	71 (1803)	78 (1981)	90 (2286)	99 (2515)
C	8 (203)	8 (203)	10 (254)	10 (254)	14 (356)	14 (356)	16 (406)	18 (457)	22 (559)	24 (610)	25 (635)	27 (686)	30 (762)
Wt.	40 (18)	55 (25)	74 (33)	110 (50)	192 (87)	317 (144)	434 (197)	657 (298)	905 (410)	1260 (571)	1590 (721)	2580 (1170)	3240 (1469)

NOTES:

*Standard construction: WCB-Trim 8, other options are available. Stockham recommends the use of manual or powered gear assistance for sizes 10" and larger.

Figure 30-OF-U

Class 300 • Outside Screw & Yoke • Flexible Wedge Disc

Material of Construction*

Description	Material
Body	WCB
Bonnet	WCB
Seat Rings	Hardfaced
Disc	CA-15 or 13% CR Overlay
Stem	410 SS
Packing	Graphite
Bonnet Gasket	Stainless Steel w/Graphite
Back Seat	410 SS
Yoke Sleeve	D2 Ni-Resist
Retaining Nut	Malleable or Steel
Gland	Steel
Gland Flange	Steel
Eye Bolt	Steel
Eye Bolt Nuts	Steel
Pins	Steel
Bonnet Studs	A193 Gr. B7
Bonnet Nuts	A194 Gr. 2H
Handwheel	Malleable, Ductile or Steel
Handwheel Nut	Ductile or Steel
I.D. Tags	SS
I.D. Pins	Steel
Spacer	Steel
Grease Fittings	Steel

NOTES:

*Standard construction: WCB-Trim 8, other options are available. Stockham recommends the use of manual or powered gear assistance for sizes 8" and larger.

Figure 30-OF-U Flanged

Size Range:
2 through 24 inches
(50 - 600 mm)

Pressure Temperature Rating

Carbon Steel
ASTM A216 Grade WCB
740 psi @ -20°F to 100°F
(51 bar @ -28°C to 37°C)

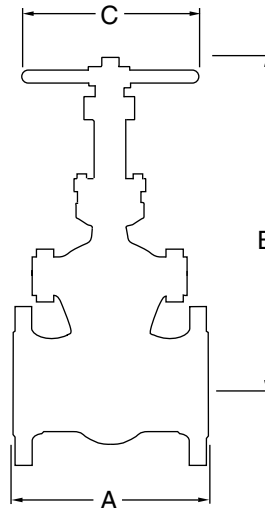
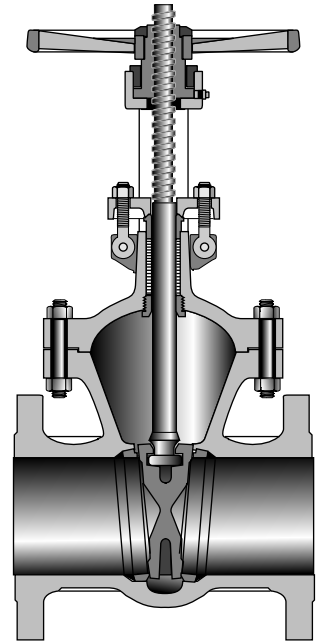

Industry Standards

Steel Valves	ASME B16.34
Face-to-Face	ASME B16.10
Flange Dimensions	ASME B16.5
Basic Design	API 600
Testing	API 598

Dimensions and Weights

Inches (millimeters) - pounds (kilograms)

Valves	2 (50)	2 ½ (65)	3 (80)	4 (100)	6 (150)	8 (200)	10 (250)	12 (300)	14 (350)	16 (400)	18 (450)	20 (500)	24 (600)
A	8.50 (216)	9.50 (241)	11.12 (282)	12.00 (305)	15.88 (403)	16.50 (419)	18.00 (457)	19.75 (502)	30.00 (762)	33.00 (838)	36.00 (914)	39.00 (990)	45.00 (1143)
B (Open)	17 (430)	20 (505)	21 (533)	24 (609)	33 (838)	40 (1008)	50 (1270)	58 (1473)	62 (1574)	71 (1803)	79 (2006)	85 (2154)	100 (2540)
C	8 (203)	10 (254)	10 (254)	10 (254)	14 (356)	16 (406)	18 (457)	20 (508)	22 (559)	24 (610)	25 (635)	30 (762)	30 (762)
Wt.	69 (31)	77 (34)	112 (50)	165 (74)	310 (140)	483 (218)	811 (368)	1151 (522)	1530 (693)	2380 (1079)	2722 (1234)	3650 (1655)	5115 (2320)

Figure 60-OF-U

Class 600 • Outside Screw & Yoke • Flexible Wedge Disc

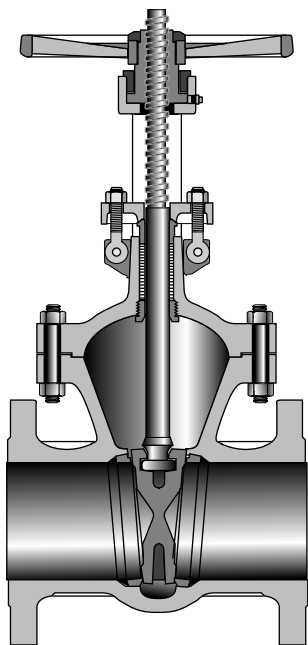

Figure 60-OF-U
Flanged

Size Range:
2 through 12 inches
(50 - 300 mm)

Pressure Temperature Rating
Carbon Steel
ASTM A216 Grade WCB
1480 psi @ -20°F to 100°F
(102 bar @ -28°C to 37°C)

Industry Standards

Steel Valves	ASME B16.34
Face-to-Face	ASME B16.10
Flange Dimensions	ASME B16.5
Basic Design	API 600
Testing	API 598

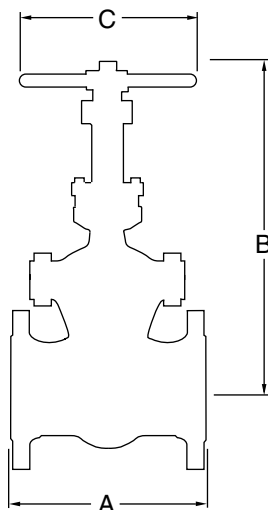

Material of Construction*

Description	Material
Body	WCB
Bonnet	WCB
Seat Rings	Hardfaced
Disc	CA-15 or 13% CR Overlay
Stem	410 SS
Packing	Graphite
Bonnet Gasket	Ring Type Soft-Iron
Back Seat	410 SS
Yoke Sleeve	D2 Ni-Resist
Retaining Nut	Malleable or Steel
Gland	Steel
Gland Flange	Steel
Eye Bolt	Steel
Eye Bolt Nuts	Steel
Pins	Steel
Bonnet Studs	A193 Gr. B7
Bonnet Nuts	A194 Gr. 2H
Handwheel	Malleable, Ductile or Steel
Handwheel Nut	Ductile or Steel
I.D. Tags	SS
I.D. Pins	Steel
Spacer	Steel
Grease Fittings	Steel

NOTES:

*Standard construction: WCB-Trim 8, other options are available. Stockham recommends the use of manual or powered gear assistance for sizes 6" and larger.

Dimensions and Weights

Inches (millimeters) - pounds (kilograms)

Valves	2 (50)	2 ½ (65)	3 (80)	4 (100)	6 (150)	8 (200)	10 (250)	12 (300)
A	11.50 (292)	13.00 (330)	14.00 (355)	17.00 (431)	22.00 (558)	26.00 (660)	31.00 (787)	33.00 (838)
B (Open)	17 (431)	19 (482)	23 (584)	27 (685)	36 (914)	42 (1066)	51 (1295)	58 (1473)
C	10 (254)	10 (254)	12 (304)	14 (355)	18 (457)	20 (508)	25 (635)	27 (685)
Wt.	99 (44)	121 (54)	170 (77)	280 (127)	590 (267)	1080 (489)	1660 (752)	2070 (938)

General Information Class 150, 300, and 600 Globe Valves

Features

Welded-in Seat Ring

- Seat ring is seal welded to eliminate leak path

Basic Standards

These valves comply with the applicable requirements of the following standards:

- API 598
- ASME B16.34
- ASME B16.10
- ASME B16.5

Notes

- Standard material is ASTM A216 Grade WCB
- Standard trim is API 8 (13% Cr to hardface) which is suitable for a wide range of applications

Typical Globe Valve Features

Stockham globe valves are highly efficient for services requiring frequent operation and throttling when pressure drop across the valve is about 20% of inlet pressure. Closer throttling, creating higher pressure drops may cause cavitation or excessive velocities which could cause high noise levels, vibration and possible damage to the valve or adjacent piping. Globe valves can be equipped with optional operators and are available with a variety of trims to match service requirements.

1. **Body:** Body is cast with heavy sections reinforced at points subjected to the greatest stress. Valves are available in flanged ends. All conform to referenced ASME specifications.
2. **Bonnet**
3. **Seat Ring**
4. **Disc**
5. **Disc Stem Nut:** Disc Stem Ring connects the disc to the stem, permitting the disc to swivel and aid in securing tight seating for trouble-free service.
6. **Disc Washer**
7. **Stem:** Stem has long engagement with yoke bushing for accurate seating.
8. **Bonnet Bushing**
9. **Yoke Bushing**
10. **Wheel Nut**
11. **Packing**
12. **Gland:** Gland is a two-piece, ball-type which exerts even pressure on the packing without binding the stem.
13. **Gland Flange**
14. **Gland Eye Bolts:** Eye bolts are securely fastened to the bonnet yet swing away to permit easy access to the stuffing box.
15. **Bonnet Gasket:** Bonnet gasket provides a positive seal against leakage. Class 150 and 300 valves have a male/female bonnet joint. A ring-type gasket is employed in Class 600.
16. **Bonnet Studs**
17. **Bonnet Nuts**
18. **Pin**
19. **Handwheel**

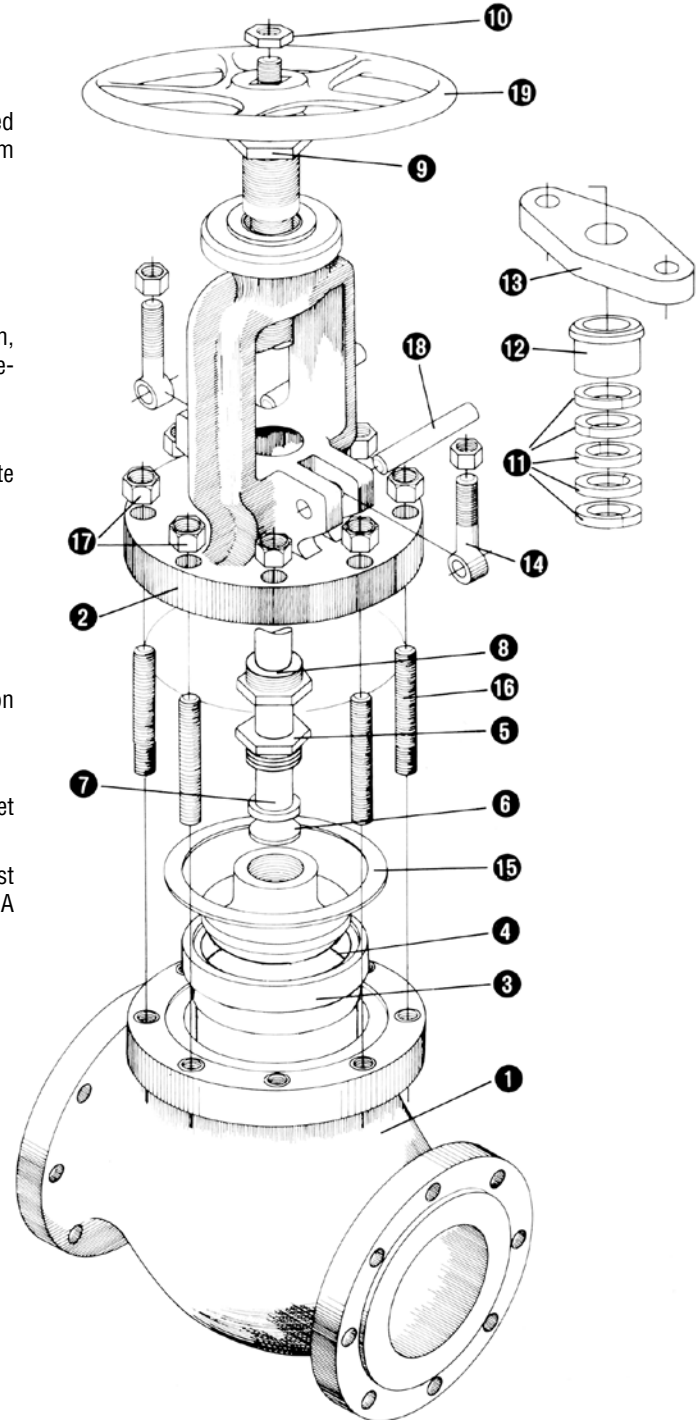

NOTE: Stockham recommends the use of gear assistance for certain multi-turn valves for optimal functional performance in larger sizes and high flow-rate applications. Please refer to the note on specific product pages.

Figure 15-GPF-U

Class 150 • Outside Screw & Yoke • Bolted Bonnet

Material of Construction*

Description	Material
Body	WCB
Bonnet	WCB
Seat Rings	Hardfaced
Disc	13% CR Overlay
Stem	410 SS
Packing	Graphite
Bonnet Gasket	Stainless Steel w/Graphite
Back Seat	410 SS
Disc Stem Nut	410 SS
Disc Washer	Carbon Steel
Gland	410 SS
Gland Flange	WCB
Eye Bolt	Steel
Eye Bolt Nuts	A194 Gr. 2H
Pins	-
Bonnet Studs	A193 Gr. B7
Bonnet Nuts	A194 Gr. 2H
Handwheel	Ductile Iron
Handwheel Nut	A194 Gr. 2H
I.D. Tags	SS
I.D. Pins	Steel

NOTES:

*Standard construction: WCB-Trim 8, other options are available. Stockham recommends the use of manual or powered gear assistance for sizes 6" and larger.

Figure 15-GPF-U Flanged

Size Range:
2 through 12 inches
(50 - 300 mm)

Pressure Temperature Rating

Carbon Steel
ASTM A216 Grade WCB
285 psi @ -20°F to 100°F
(20 bar @ -28°C to 37°C)

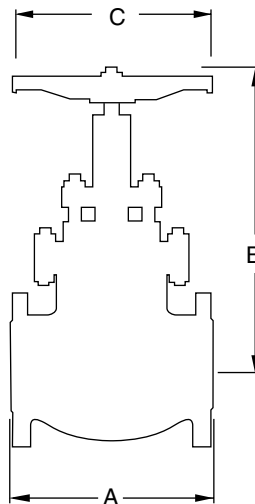
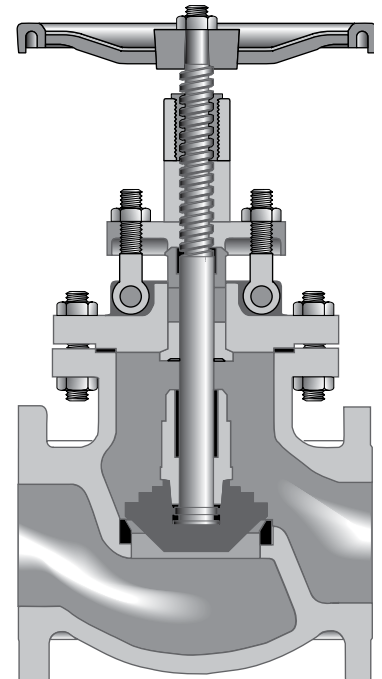

Industry Standards

Steel Valves	ASME B16.34
Face-to-Face	ASME B16.10
Flange Dimensions	ASME B16.5
Testing	API 598

Dimensions and Weights

Inches (millimeters) - pounds (kilograms)

Valves	2 (50)	2 ½ (65)	3 (80)	4 (100)	6 (150)	8 (200)	10 (250)	12 (300)
A	8.00 (203)	8.50 (216)	9.50 (241)	11.50 (292)	16.00 (406)	19.50 (495)	24.50 (622)	27.50 (698)
B (Open)	14 (356)	16 (406)	16 (406)	19 (482)	21 (533)	24 (610)	29 (736)	40 (1016)
C	8 (203)	8 (203)	10 (254)	12 (304)	14 (355)	18 (457)	18 (457)	24 (610)
Wt.	48 (21)	70 (31)	92 (41)	132 (59)	223 (101)	355 (161)	640 (290)	1200 (550)

Figure 30-GPF-U

Class 300 • Outside Screw & Yoke • Bolted Bonnet

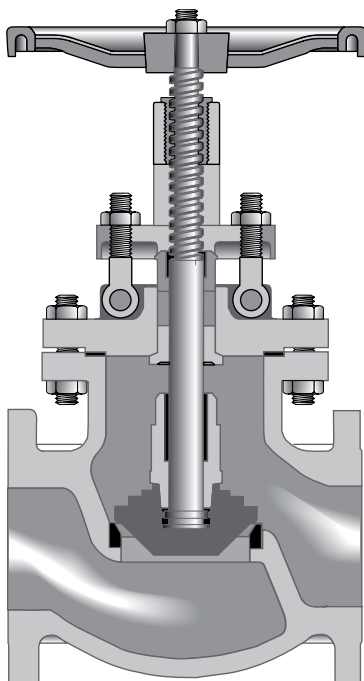

Figure 30-GPF-U
Flanged

Size Range:
2 through 12 inches
(50 - 300 mm)

Pressure Temperature Rating
Carbon Steel
ASTM A216 Grade WCB
740 psi @ -20°F to 100°F
(51 bar @ -28°C to 37°C)

Industry Standards

Steel Valves	ASME B16.34
Face-to-Face	ASME B16.10
Flange Dimensions	ASME B16.5
Testing	API 598

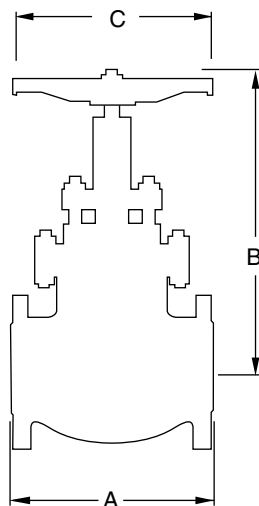

Material of Construction*

Description	Material
Body	WCB
Bonnet	WCB
Seat Rings	Hardfaced
Disc	13% CR Overlay
Stem	410 SS
Packing	Graphite
Bonnet Gasket	Stainless Steel w/Graphite
Back Seat	410 SS
Disc Stem Nut	410 SS
Disc Washer	Carbon Steel
Gland	410 SS
Gland Flange	WCB
Eye Bolt	Steel
Eye Bolt Nuts	A194 Gr. 2H
Pins	-
Bonnet Studs	A193 Gr. B7
Bonnet Nuts	A194 Gr. 2H
Handwheel	Ductile Iron
Handwheel Nut	A194 Gr. 2H
I.D. Tags	SS
I.D. Pins	Steel

NOTES:

*Standard construction: WCB-Trim 8, other options are available. Stockham recommends the use of manual or powered gear assistance for sizes 6" and larger.

Dimensions and Weights

Inches (millimeters) - pounds (kilograms)

Valves	2 (50)	2 ½ (65)	3 (80)	4 (100)	6 (150)	8 (200)	10 (250)	12 (300)
A	10.50 (267)	11.50 (292)	12.50 (317)	14.00 (356)	17.50 (444)	22.00 (558)	24.50 (622)	28.00 (711)
B (Open)	15 (381)	18 (457)	18 (457)	21 (533)	25 (635)	36 (914)	41 (1041)	51 (1295)
C	8 (203)	10 (254)	10 (254)	14 (355)	18 (457)	18 (457)	22 (559)	26 (638)
Wt.	69 (31)	99 (44)	128 (58)	190 (86)	330 (149)	330 (149)	700 (317)	1360 (616)

Figure 60-GPF-U

Class 600 • Outside Screw & Yoke • Bolted Bonnet

Material of Construction*

Description	Material
Body	WCB
Bonnet	WCB
Seat Rings	Hardfaced
Disc	13% CR Overlay
Stem	410 SS
Packing	Graphite
Bonnet Gasket	Ring Type Soft-Iron
Back Seat	410 SS
Disc Stem Nut	410 SS
Disc Washer	Carbon Steel
Gland	410 SS
Gland Flange	WCB
Eye Bolt	Steel
Eye Bolt Nuts	A194 Gr. 2H
Pins	-
Bonnet Studs	A193 Gr. B7
Bonnet Nuts	A194 Gr. 2H
Handwheel	Ductile Iron
Handwheel Nut	A194 Gr. 2H
I.D. Tags	SS
I.D. Pins	Steel

NOTES:

*Standard construction: WCB-Trim 8, other options are available. Stockham recommends the use of manual or powered gear assistance for sizes 4" and larger.

Figure 60-GPF-U Flanged

Size Range:
2 through 8 inches
(50 - 200 mm)

Pressure Temperature Rating

Carbon Steel
ASTM A216 Grade WCB
1480 psi @ -20°F to 100°F
(102 bar @ -28°C to 37°C)

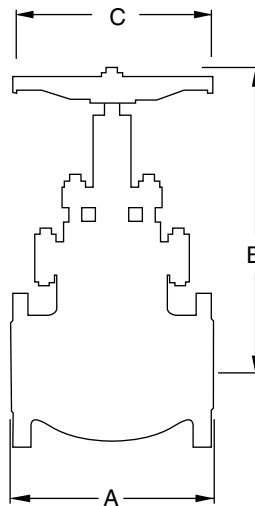
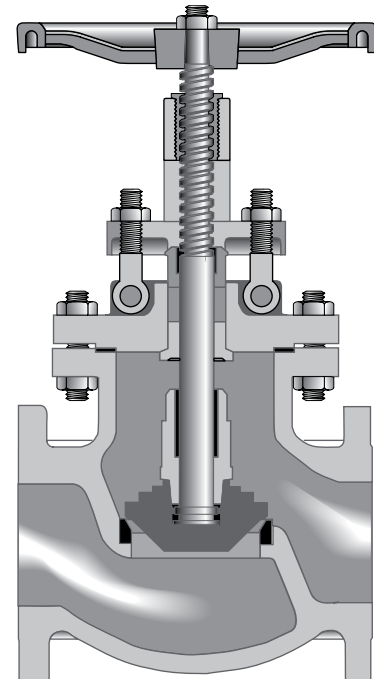

Industry Standards

Steel Valves	ASME B16.34
Face-to-Face	ASME B16.10
Flange Dimensions	ASME B16.5
Testing	API 598

Dimensions and Weights

Inches (millimeters) - pounds (kilograms)

Valves	2 (50)	2 ½ (65)	3 (80)	4 (100)	6 (150)	8 (200)
A	11.50 (292)	13.00 (330)	14.00 (356)	17.00 (431)	22.00 (558)	26.00 (660)
B (Open)	19 (482)	21 (533)	23 (584)	27 (685)	33 (838)	36 (914)
C	10 (254)	10 (254)	14 (355)	18 (457)	20 (508)	26 (660)
Wt.	126 (57)	154 (69)	188 (85)	270 (122)	890 (403)	990 (449)

General Information Class 150, 300 and 600 Swing Check

Features

Disc Type

- For class 600 valves, a ring joint bonnet gasket assures positive seal against leakage and accurate alignment of moving parts

Welded-in Seat Ring

- Seat ring is seal welded to eliminate leak path

Internal Hung Design

- Eliminates additional leak paths

Standards

These valves comply with the applicable requirements of the following standards:

- API 598
- ASME B16.34
- ASME B16.10
- ASME B16.5

Notes

- Standard material is ASTM A216 Grade WCB
- Standard trim is API #8 (13% Cr to hardface) which is suitable for a wide range of applications

Typical Swing Check Valve Features

Check valves are automatically actuated. They are opened and sustained in the open position by the force of velocity pressure, and closed by the force of gravity. Seating load and resultant tightness is dependent upon back pressure. The disc and associated moving parts may be in a constant state of movement if the velocity pressure is not sufficient to hold the valve in a wide open and stable position. Premature wear and noisy operation or vibration of the moving parts can be avoided by selecting the size of check valve on the basis of flow conditions. The minimum velocity required to hold a swing check valve in the wide open and stable position has been developed by analysis of extensive test data and is expressed by the formula:

$$v = 60 \sqrt{\bar{v}}$$

The value for v is equal to flow in feet per second and \bar{v} is the specific volume of fluid in cubic feet per pound. Sizing swing check valves on this basis may often result in the use of valves that are smaller than the pipe in which they are used, necessitating the use of reducers for installation. The pressure drop will be no greater than that of the larger valve that is only partially open, and valve life will be greatly extended. The added bonus, of course, is the lower cost of the smaller valve.

There is no tendency for the seating surfaces of swing check valves to gall or score, because the disc meets the flat seat squarely without rubbing contact upon closing.

Stockham cast steel swing check valves are an internally hung design and cannot be supplied with outside lever and weight features. This eliminates additional possible leak paths.

Swing check valves are used to prevent reversal of flow in horizontal pipelines. Stockham does not recommend the use of swing check valves in vertical pipelines; however when using this style of valve in a vertical application, the valve must be installed for upward flow only.

Recommended piping practice dictates that check valves be installed with a minimum of 10-15 pipe diameters distance between the check valve and any adjacent flange fitting or pump, otherwise flow fluctuation can result in damage to the valve or piping.

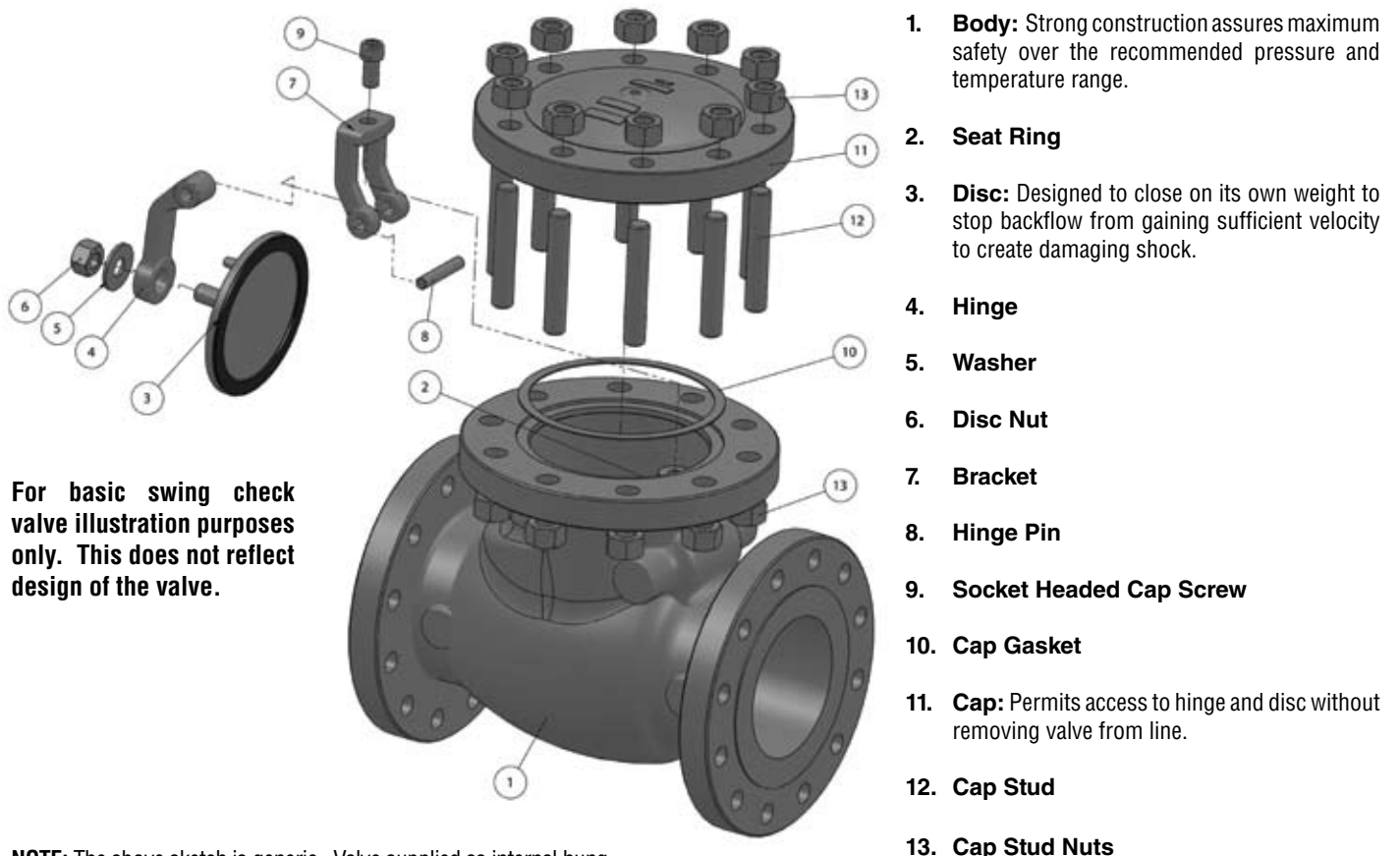

For basic swing check valve illustration purposes only. This does not reflect design of the valve.

NOTE: The above sketch is generic. Valve supplied as internal hung.

Figure 15-SF-U

Class 150 • Bolted Cap

Figure 15-SF-U
Flanged

Size Range:
2 through 24 inches
(50 - 600 mm)

Pressure Temperature Rating
Carbon Steel
ASTM A216 Grade WCB
285 psi @ -20°F to 100°F
(20 bar @ -28°C to 37°C)

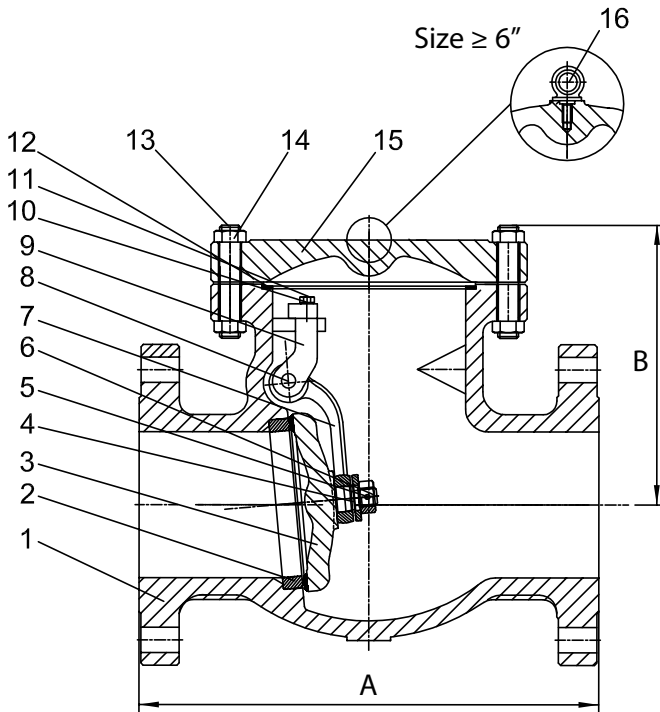

Material of Construction*

Item	Description	Material
1	Body	ASTM A216 Gr. WCB
2	Seat Ring	ASTM A105 Hard-Faced
3	Disc	ASTM A216 Gr. WCB + CR13 Faced
4	Disc Washer	ASTM A276 Type 410
5	Disc Nut Pin	Stainless Steel
6	Disc Nut	Stainless Steel
7	Hinge	ASTM A216 Gr. WCB
8	Hinge Pin	ASTM A276 Type 410
9	Bearing Bracket	ASTM A216 Gr. WCB
10	Spring Washer	Carbon Steel
11	Hex, Bolt	Carbon Steel
12	Gasket	Stainless Steel w/Graphite
13	Cover Bolt	ASTM A193 Gr. B7
14	Cover Bolt Nut	ASTM A194 Gr. 2H
15	Cover	ASTM A216 Gr. WCB
16	Eye Bolt	ASTM A181

NOTE:

*Standard construction: WCB-Trim 8, other options are available.

Industry Standards

Steel Valves	ASME B16.34
Face-to-Face	ASME B16.10
Flange Dimensions	ASME B16.5
Testing	API 598

Dimensions and Weights

Inches (millimeters) - pounds (kilograms)

Valves	2 (50)	2 ½ (65)	3 (80)	4 (100)	6 (150)	8 (200)	10 (250)	12 (300)	14 (350)	16 (400)	18 (450)	20 (500)	24 (600)
A	8.00 (203)	8.50 (216)	9.50 (241)	11.50 (292)	14.00 (356)	19.50 (495)	24.50 (622)	27.50 (698)	31.00 (787)	34.00 (863)	38.50 (977)	38.50 (977)	51.00 (1295)
B	9 (229)	7 (178)	7 (178)	9 (229)	11 (279)	13 (330)	15 (381)	17 (432)	15 (381)	17 (432)	18 (457)	19 (482)	22 (558)
Wt.	41 (18)	57 (25)	64 (29)	101 (45)	170 (77)	360 (163)	485 (219)	765 (346)	950 (430)	1225 (555)	1700 (771)	1850 (839)	2600 (1179)

Figure 30-SF-U

Class 300 • Bolted Cap

Material of Construction*

Item	Description	Material
1	Body	ASTM A216 Gr. WCB
2	Seat Ring	ASTM A105 Hard-Faced
3	Disc	ASTM A216 Gr. WCB + CR13 Faced
4	Disc Washer	ASTM A276 Type 410
5	Disc Nut Pin	Stainless Steel
6	Disc Nut	Stainless Steel
7	Hinge	ASTM A216 Gr. WCB
8	Hinge Pin	ASTM A276 Type 410
9	Bearing Bracket	ASTM A216 Gr. WCB
10	Spring Washer	Carbon Steel
11	Hex, Bolt	Carbon Steel
12	Gasket	Stainless Steel w/Graphite
13	Cover Bolt	ASTM A193 Gr. B7
14	Cover Bolt Nut	ASTM A194 Gr. 2H
15	Cover	ASTM A216 Gr. WCB
16	Eye Bolt	ASTM A181

NOTE:

*Standard construction: WCB-Trim 8, other options are available.

Industry Standards

Steel Valves	ASME B16.34
Face-to-Face	ASME B16.10
Flange Dimensions	ASME B16.5
Testing	API 598

Figure 30-SF-U
Flanged

Size Range:
2 through 24 inches
(50 - 600 mm)

Pressure Temperature Rating
Carbon Steel
ASTM A216 Grade WCB
740 psi @ -20°F to 100°F
(51 bar @ -28°C to 37°C)

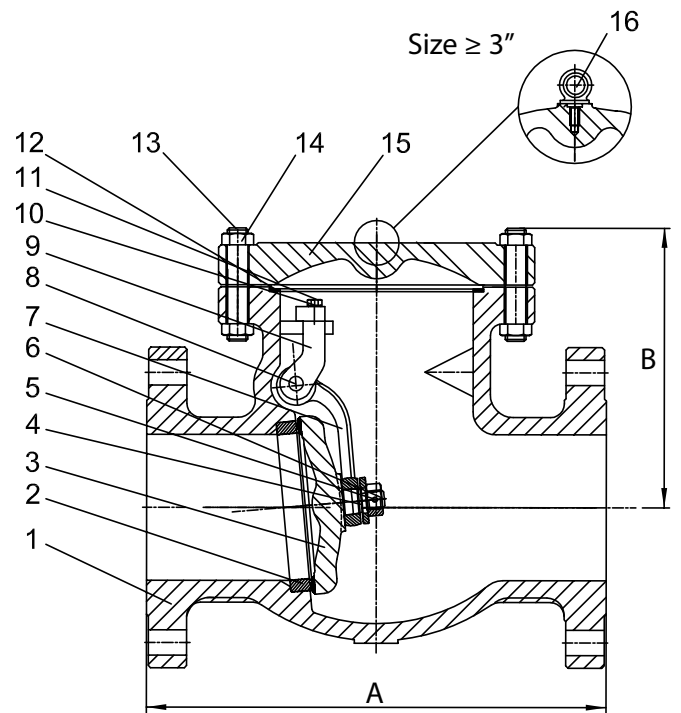

Dimensions and Weights

Inches (millimeters) - pounds (kilograms)

Valves	2 (50)	2 1/2 (65)	3 (80)	4 (100)	6 (150)	8 (200)	10 (250)	12 (300)	14 (350)	16 (400)	18 (450)	20 (500)	24 (600)
A	10.50 (266)	11.50 (292)	12.50 (317)	14.00 (356)	17.50 (444)	21.00 (533)	24.50 (622)	28.00 (711)	33.00 (838)	34.00 (863)	38.50 (977)	40.00 (1016)	53.00 (1346)
B	7 (178)	8 (203)	8 (203)	9 (229)	11 (279)	14 (355)	16 (406)	19 (482)	19 (482)	22 (558)	23 (584)	25 (635)	30 (762)
Wt.	46 (20)	66 (29)	86 (39)	154 (69)	276 (125)	460 (208)	675 (306)	860 (390)	1500 (680)	1850 (839)	2250 (1020)	2900 (1315)	4350 (1973)

Figure 60-SF-U

Class 600 • Bolted Cap

Figure 60-SF-U
Flanged

Size Range:
2 through 12 inches
(50 - 300 mm)

Pressure Temperature Rating
Carbon Steel
ASTM A216 Grade WCB
1480 psi @ -20°F to 100°F
(102 bar @ -28°C to 37°C)

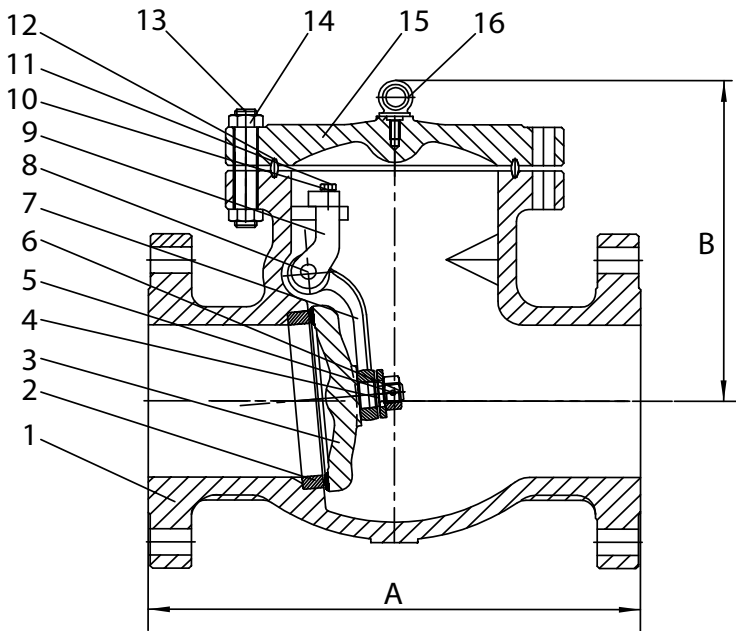

Material of Construction*

Item	Description	Material
1	Body	ASTM A216 Gr. WCB
2	Seat Ring	ASTM A105 Hard-Faced
3	Disc	ASTM A216 Gr. WCB + CR13 Faced
4	Disc Washer	ASTM A276 Type 410
5	Disc Nut Pin	Stainless Steel
6	Disc Nut	Stainless Steel
7	Hinge	ASTM A216 Gr. WCB
8	Hinge Pin	ASTM A276 Type 410
9	Bearing Bracket	ASTM A216 Gr. WCB
10	Spring Washer	Carbon Steel
11	Hex, Bolt	Carbon Steel
12	Gasket	Ring Type Soft-Iron
13	Cover Bolt	ASTM A193 Gr. B7
14	Cover Bolt Nut	ASTM A194 Gr. 2H
15	Cover	ASTM A216 Gr. WCB
16	Eye Bolt	ASTM A181

NOTE:

*Standard construction: WCB-Trim 8, other options are available.

Industry Standards

Steel Valves	ASME B16.34
Face-to-Face	ASME B16.10
Flange Dimensions	ASME B16.5
Testing	API 598

Dimensions and Weights

Inches (millimeters) - pounds (kilograms)

Valves	2 (50)	2 ½ (65)	3 (80)	4 (100)	6 (150)	8 (200)	10 (250)	12 (300)
A	11.50 (292)	13.00 (330)	14.00 (356)	17.00 (431)	22.00 (558)	26.00 (660)	31.00 (787)	33.00 (838)
B	7 (178)	8 (203)	9 (229)	11 (279)	13 (330)	16 (406)	19 (482)	21 (533)
Wt.	115 (52)	145 (65)	161 (73)	284 (128)	500 (226)	1025 (464)	1400 (635)	1950 (884)

Pressure/Temperature Ratings

ENGLISH UNITS

The following pressure-temperature charts are derived from ASME B16.34 - 2004 Version. They will cover the most commonly used body and bonnet materials in the industry. All Stockham valves are designed to operate through the pressure and temperature ranges shown in these charts for a particular ASME Class Rating and ASTM Material.

ASTM A216 GR WCB

°F	STANDARD CLASS B16.34 - 2004 MAXIMUM NON-SHOCK WORKING PRESSURE, PSIG					
	150	300	600	900	1500	2500
-20 to 100	285	740	1480	2220	3705	6170
200	260	680	1360	2035	3395	5655
300	230	655	1310	1965	3270	5450
400	200	635	1265	1900	3170	5280
500	170	605	1205	1810	3015	5025
600	140	570	1135	1705	2840	4730
650	125	550	1100	1650	2745	4575
700	110	530	1060	1590	2665	4425
750	95	505	1015	1520	2535	4230
800	80	410	825	1235	2055	3430

NOTE: Upon prolonged exposure to temperatures above 800°F (426°C), the carbide phase of steel may be converted to graphite. Permissible, but not recommended for prolonged use above 800°F (426°C).

Notes



CRANE Energy Flow Solutions™

CRANE Energy Global Headquarters
4526 Research Forest Drive, Suite 400
The Woodlands, Texas 77381 U.S.A.
Tel.: (1) 936-271-6500
Fax.: (1) 936-271-6510

Stockham Customer Service
2129 3rd Avenue, S.E.
Cullman, Alabama 35055
Tel.: (1) 800-STOCKHAM
Fax.: (1) 256-775-3860

www.craneenergy.com



Energy Flow Solutions



brands you trust.



EG-SC-CT-EN-L16-03-1107 (CV-807)

Crane Co., and its subsidiaries cannot accept responsibility for possible errors in catalogues, brochures, other printed materials, and website information. Crane Co. reserves the right to alter its products without notice, including products already on order provided that such alteration can be made without changes being necessary in specifications already agreed. All trademarks in this material are property of the Crane Co. or its subsidiaries. The Crane and Crane brands logotype (Aloyco®, Center Line®, Compac-Noz®, Crane®, Duo-Chek®, Flowseal®, Jenkins®, Krombach®, Noz-Chek®, Pacific Valves®, Stockham®, Triangle®, Uni-Chek®) are registered trademarks of Crane Co. All rights reserved.