

AVID Z SERIES ROTARY VALVE MONITOR

GENERAL PURPOSE / HAZARDOUS AREA

Providing integrated monitoring and control of automated process valves the Z series is designed for both general purpose and hazardous area applications



GENERAL APPLICATION

The Z-series rotary valve monitors allow integrated valve monitoring and control from a single switchbox. Designed for direct mounting to quarter turn rotary actuators and suitable for both general purpose and hazardous area applications.

AGENCY APPROVALS

Area classifications (ATEX/IEC)	
ATEX / IECEx	Ex ia Ex mb e
Environmental protection	
IEC	IP66/67
ANSI/NEMA 250	Type 4, 4X

TECHNICAL DATA

Switches	Micro switch V3 mechanical T-switch for Increased Safety and Encapsulation Proximity type sensor (inductive)
Materials	
Enclosure	Engineered resin / aluminum / stainless steel
Solenoid valves	Aluminum / stainless steel
Enclosure specification	
Conduit entries	1 x M20 / 1/2" NPT (with solenoid valve) 2 x M20 / 1/2" NPT (no solenoid valve)
Terminal strip	8 points
Temperature range	-40°C to +85°C (depending on configuration / certification)

FEATURES

- Vibration resistant EasiFix self-locking cams are adjustable by hand
- ModMount assembly allows direct mounting to Crane CPE rack and pinion actuators
- Impact and corrosion resistant HiVue local visual indicator
- Lightweight and robust engineered resin enclosure
- Rugged aluminum and stainless steel enclosures
- Position detection available with mechanical switch, proximity switch and inductive proximity sensors
- Up to 4 off SPDT Form C micro-switches, V3 Inductive proximity sensors or Proximity T-switches
- Z+ series offers solenoid valves pre-wired and integrated within the enclosure
- Network control modules for Profibus DP, DeviceNet, Modbus, AS-i and Foundation Fieldbus protocols available.
- Models suitable for various classifications of hazardous area
- All units are manufactured to IP66/67 and NEMA 4, 4X weatherproof ratings
- Z series valve monitors provide SIL 2 capable systematic integrity
- Breather plug available

AVID Z SERIES ROTARY VALVE MONITOR

GENERAL PURPOSE / HAZARDOUS AREA

STANDARD FEATURES

The AVID Z series is available as a position monitor in various enclosure materials with a choice of switches and sensors, as a control monitor with the addition of an integral solenoid valve and as a network control monitor with a network module suitable for AS-i, Foundation Fieldbus and other network protocols.

All AVID rotary valve monitors have the following features:

HiVue local visual indicator

All models are fitted with an impact and corrosion resistant HiVue local visual indicator, capable of displaying exact valve position from any quadrant at distances of up to 50 meters.



ModMount assembly

The specially designed ModMount low-profile mounting assembly directly mounts AVID rotary valve monitors to all CRANE CPE rack and pinion actuators (ZS uses SS bracket).



EasiFix switch adjustment

Vibration resistant self-locking cams are fastened to a splined shaft and can easily be set or adjusted by hand in seconds. Since there are no setscrews, the cams will never slip out of adjustment.



SWITCHES AND SENSORS

AVID Z series rotary valve monitors can be fitted with a variety of switches and sensors to provide the optimum combination and ideal solution for each application. A selection of standard switches & sensors is listed on page 3.

Micro switch V3 mechanical

A V3 SPDT (single pole double throw) mechanical switch (Form C).

Technical data

Electrical version SPDT Form C

T-switch

Hermetically sealed proximity switch with rhodium contacts for use with low power I/Os to provide longer contact life.

Technical data

Electrical version	SPDT Form C normally closed
Contacts	Rhodium
Contact resistance	0.08 ohms
Seal	Encapsulated design

Proximity type sensor (inductive)

A solid state inductive proximity sensor which is available in NAMUR output. It is ideal for use in devices within potentially explosive atmospheres.

Technical data

Electrical version	DC voltage 2 wire in accordance with EN 60947-5-6
Switching frequency	1.0 kHz
Nominal voltage	8 V DC
Input voltage range	Dependent on barrier used

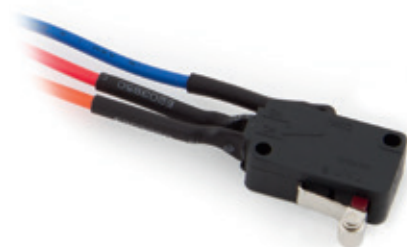

AVID Z SERIES ROTARY VALVE MONITOR

GENERAL PURPOSE / HAZARDOUS AREA

STANDARD SWITCH / SENSOR SELECTION

The table below shows a number of standard switch / sensor options. For details and availability of other switches / sensors please contact your local sales office.

NON-HAZARDOUS APPLICATIONS

Area classification	Type of protection	Output	Voltage	Current	Housing	Temperature range	Sensor model
General Purpose	N/A	3-wire SPDT	24 V DC	6 A at 24 V DC	V3	0°C to 85°C	V3 SPDT Mechanical (Silver)
General Purpose	N/A	3-wire SPDT	125 V AC	5 A at 125 V AC	V3	0°C to 85°C	V3 SPDT Mechanical (Silver)
General Purpose	N/A	3-wire SPDT	250 V AC	10 A at 250 VAC	V3	0°C to 85°C	V3 SPDT Mechanical (Silver)
General Purpose	N/A	3-wire DC PNP	10 to 60 V DC	< 200 mA	M12 Barrel	-25°C to 70°C	P&F NJ2-12GM40-E2
General Purpose	N/A	3-wire DC PNP	10 to 36 V DC	< 15 mA at 24 V DC	V3	-25°C to 80°C	IFM IS 5001
General Purpose	N/A	2-wire DC PNP/NPN	5 to 36 V DC	< 200 mA at 24 V DC	V3	-25°C to 80°C	IFM IS 5026

HAZARDOUS AREA APPLICATIONS

Area classification	Type of protection	Output	Voltage	Current	Housing	Temperature range	Sensor model
1G, 1D	Ex ia	3-wire SPDT	24 V DC	<100 mA	V3	0°C to 85°C	V3 SPDT Mechanical (Gold)
3G, 3D	Ex nA	3-wire DC PNP	1 to 30 V DC	<100 mA	V3	-25°C to 70°C	P&F NBB2-V3-E2-3G-3D
2G, 2D	Ex mb e	3-wire SPDT	24 V DC /	1.5 A	AVID	-30°C to 90°C	T-switch SPDT Proximity
2G, 2D	Ex mb e	3-wire SPDT	120 V AC	2 A	AVID	-30°C to 90°C	T-switch SPDT Proximity
2G, 2D	Ex mb e	3-wire SPDT	250 V AC	1 A	AVID	-30°C to 90°C	T-switch SPDT Proximity
1G, 1D	Ex ia	2-wire Namur (NC)	8.2 V Namur	≤ 1 mA / > 3 mA	M14 Barrel	-25°C to 100°C	P&F NJ2-11-N-G *
1G, 1D	Ex ia	2-wire Namur (NC)	8.2 V Namur	≤ 1 mA / > 3 mA	V3	-25°C to 100°C	P&F NJ2-V3-N *
1G, 1D	Ex ia	2-wire Namur (NC)	8.2 V Namur	≤ 1 mA / > 3 mA	Slotted	-25°C to 100°C	P&F SJ3.5-N *
1G, 1D	Ex ia	2-wire Namur (NO)	8.2 V Namur	≤ 1 mA / > 3 mA	Slotted	-40°C to 100°C	P&F SJ3.5-SN *

* ATEX, UL & CSA certification available

NOTE

Temperature range is dependant on configuration and certification

AVID Z SERIES ROTARY VALVE MONITOR

GENERAL PURPOSE / HAZARDOUS AREA

SOLENOID VALVES

The addition of a solenoid valve provides integrated monitoring and control of automated process valves. AVID solenoid valves are engineered specifically to address low power valve actuation requirements and are available for single acting or double acting actuators.

Features

- Non-venting design with visual spool position indicator and manual override as standard
- A high C_v value of 1.1 is standard on all valves
- Alternative manual override options available
- ETS (exhaust to spring) option eliminates potential actuator contamination.
- Offers speed control to meet lower C_v requirements where necessary.
- Optimized port positions for easy piping and minimized weather intrusion.
- Operates in any position.

Technical data

C_v	1.1
Air connection	1/4" NPT or G1/4 ISO228
Mechanical spec.	3/2-way or 5/2-way
Electrical spec.	Normally closed
Pressure rating	3 to 10 bar
Operating media	Air / Inert gas
Operations	1,000,000 (typical)
Mounting	Any position
Temp. range	-20°C to +80°C

Solenoid coils (standard)

Standard coils are available in 24 V DC, 120 V AC and 250 V AC, they can be supplied for both general purpose and hazardous area applications. Please specify your requirements when ordering.

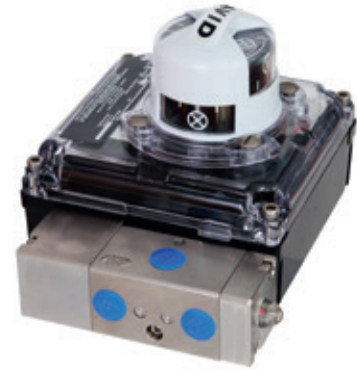

AVID Z SERIES ROTARY VALVE MONITOR

GENERAL PURPOSE / HAZARDOUS AREA

FIELDBUS COMMUNICATION

Fieldbus network

A field communications network comprises a specific number of PlantNet monitors interconnected by a common communications protocol. PlantNet monitors may be placed on the field network in any physical order. Each monitor is assigned a unique address and accepts input/output signals from valve position sensors, solenoid valves and external devices.

Communication with a PLC, DCS or host computer is accomplished by a compatible gateway interface or scanner card.

AVID PlantNet

AVID PlantNet modules use embedded control systems to automate valves and link field I/O to the host PLC or DCS. They incorporate all the features of standard AVID control monitors with the addition of a network I/O module.

Each PlantNet monitor typically houses two discrete Hall effect sensors for valve position monitoring, a low power solenoid valve for actuation control and a network interface module for communication via the chosen network protocol. Monitors are available for rotary applications in all area classifications.

The network module

Each AVID model contains a dedicated network module that is integrated within its enclosure. The module is factory-integrated depending upon the network protocol selected. The modular design enables the simple conversion from one network protocol to another (with the sole exception of FOUNDATION Fieldbus™) in the field by authorized personnel, should the need arise. Integrated network modules have protective diodes and optical isolation as standard.

Standard network protocols

The development of standard network protocols has made it possible to integrate process control components into a network effectively. AVID network modules are available for DeviceNet™, Modbus®, AS-interface®, Profibus DP and FOUNDATION Fieldbus™ protocols. They are proven to be extremely reliable, simple to understand and consistently cost-effective. They integrate simply with all major PLCs and DCS systems via off-the-shelf gateway interfaces.

For further information see our dedicated AVID network control monitor data sheet.

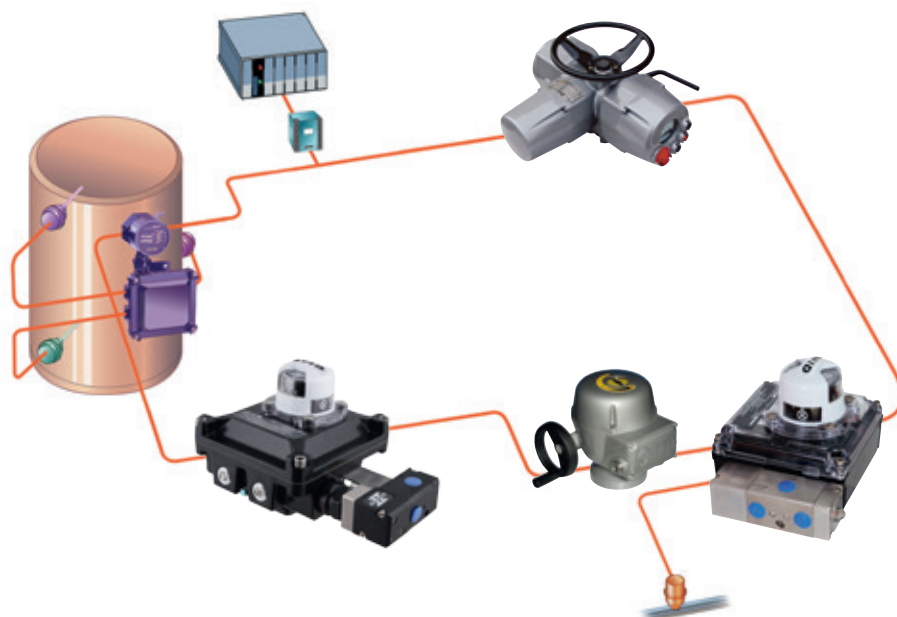

AVID Z SERIES ROTARY VALVE MONITOR

GENERAL PURPOSE / HAZARDOUS AREA

Z SERIES ENCLOSURE DIMENSIONS

No solenoid valve

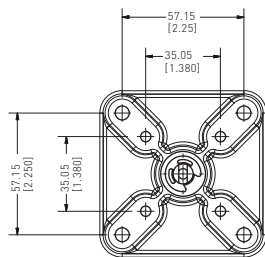
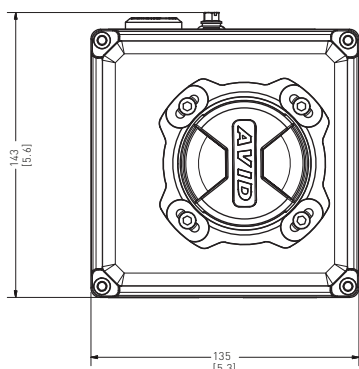

Detail view of housing bracket positions (NAMUR)

With solenoid valve

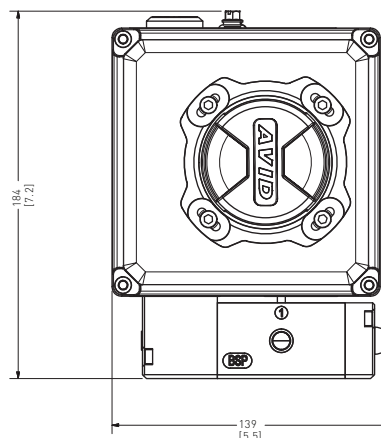

Overall dimensions (with 1/2 way valve and shaft coupler)

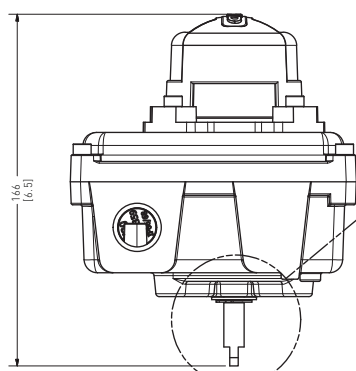

NAMUR shaft option

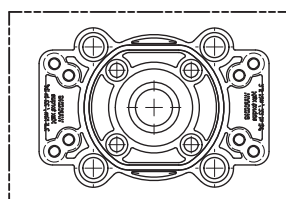
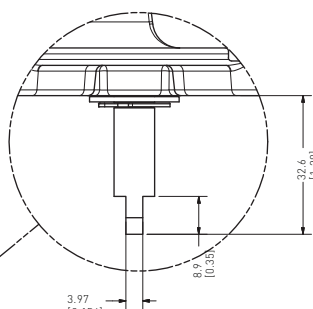

ModMount top view

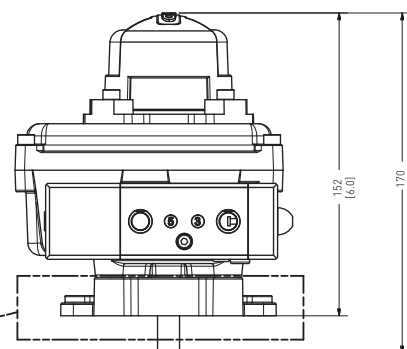

ModMount [standard]

All dimensions are nominal
Dimensions in mm, imperial dimensions (inches) in parentheses

MATERIALS OF CONSTRUCTION

Model	ZR	ZA	ZS
Item	Material		
Enclosure	Engineered Resin	Aluminum	Stainless steel
Shaft	Stainless steel	Stainless steel	Stainless steel
Bushing	Nylon	Oil impregnated bronze	Nylon
Fasteners	Stainless steel	Stainless steel	Stainless steel
HiVue	Co-polyester	Co-polyester	Co-polyester
ModMount	Nylon	Nylon	Nylon

Solenoid valves	Aluminum	316 Stainless steel
Valve body	Black anodized aluminum	Passivated 316 SS
Pilot piston end cap	Black anodized aluminum	Passivated 316 SS
Spring end cap	Black anodized aluminum	Passivated 316 SS
Spool	PTFE impregnated hard anodized aluminum	303 SS
Seals	Nitrile	Nitrile
Bushes	Brass	Brass
Spring	Stainless steel	Stainless steel



AVID Z SERIES CODING GUIDE

GENERAL PURPOSE / HAZARDOUS AREA

Base model

Z

Materials of construction

- R Resin
- A Aluminum
- S Stainless steel

Application

- | | |
|--|-----------------------|
| 0 No solenoid | D DeviceNet |
| 7 AVID 1.1 C _v single coil solenoid | F FOUNDATION Fieldbus |
| C Position transmitter 4 - 20 mA | P PROFIBUS DP |
| A AS-interface | |

Conduit entry

- | | |
|---------------------------------------|------------------------------------|
| 1 ½" NPT x one (solenoid option only) | 8 M25 x one (solenoid option only) |
| 2 M20 x one (solenoid option only) | A ½"NPT x two (no solenoid) |
| 5 ¾" NPT x one (solenoid option only) | B M20 x two (no solenoid) |

Number of switches

- | | |
|-------|-----------------------------------|
| 1 One | 3 Three (no solenoid option only) |
| 2 Two | 4 Four (no solenoid option only) |

Switch option

- | | |
|-------------------------------------|-------------------------|
| 01 V3 SPDT mechanical (silver) 16 | 57 P&F NBB2-V3-E2-3G-3D |
| V3 SPDT mechanical (gold) | 18 P&F NJ2-11-NG |
| 02 CRANE CPE T-switch SPDT | 23 P&F NJ2-12GM40-E2 |
| proximity 06 PlantNet (hall effect) | 03 P&F NJ2-V3-N |
| 11 IFM IS 5001 | 04 P&F SJ3.5-N |
| 10 IFM IS 5026 | 37 P&F SJ3.5-SN |

Terminal strip

- B 8 Point (standard)
- C 9 Point
- D 10 Point

Mounting

- D ModMount metric fixings
- I ModMount imperial fixings
- 0 NAMUR mounting / No ModMount [ZS standard]

Solenoid coil voltage

- 0 Not applicable
- 1 24 V DC Non hazardous
- 2 24 V DC Intrinsically Safe
- 3 24 V DC Ex m
- 4 110 V AC Non hazardous
- 5 110 V AC Ex m
- 6 240 V AC Non hazardous
- 7 240 V AC Ex m

Solenoid valve body type

- 0 Not applicable
- 4 Aluminum ¼" NPT 5/2 way, Hex O/Ride
- C Aluminum ¼" BSP 5/2 way, Hex O/Ride
- F 316 Stainless steel ¼" BSP 5/2 way, Hex O/Ride
- 2 316 Stainless steel ¼"NPT 5/2 way, Hex O/Ride

Special feature

- 00 Standard build
- XX Consult with sales office

Certification

- 0 Non hazardous
- A ATEX
- F North American
- I IECEx

Revision

- R Revision number

Z R - 0 B 2 03 B D 0 0 - 00 A R1 Model number **ZR-0B203BD00-00AR1**

Note: Contact your local sales office for any specific requirements not shown in this guide.

Westlock
Controls

280 N. Midland
Avenue,

Ste 258

Saddle Brook, NJ
07663

United States

Crane Co., and its subsidiaries cannot accept responsibility for possible errors in catalogues, brochures, other printed materials, and website information. Crane

Co. reserves the right to alter its products without notice, including products already on order provided that such alteration can be made without changes being

necessary in specifications already agreed. All trademarks in this material are the property of the Crane Co. or its subsidiaries. The Crane and Crane brands logotype,

in alphabetical order, (ALOYCO®, CENTER LINE®, COMPAC-NOZ®, CRANE®, DEPA®, DUO-CHEK®, ELRO®, FLOWSEAL®, JENKINS®, KROMBACH®, NOZ-CHEK®, PACIFIC

VALVES®, RESISTOFLEX®, REVO®, SAUNDERS®, STOCKHAM®, TRIANGLE®, UNI-CHEK®, WTA®, and XOMOX®) are registered trademarks of Crane Co. All rights reserved.