

AVID LP R2

INSTALLATION AND OPERATING INSTRUCTIONS

Installation and operating instructions for AVID LP R2 with SPDT V3 Microswitches, V3 Inductive Proximity Sensors or T-Switches.

The following document details the installation, operation and maintenance instructions for the AVID LP R2 (low profile) giving 360° visual and electrical valve position.

1.0 MOUNTING INSTRUCTIONS

NOTE

All AVID LP switchboxes are factory equipped with direct and NAMUR mounting.

- 1.1 Please refer to the figures 1 and 2 below to determine the type of mounting that is required.
Figure 1 indicates the conventional direct mount and figure 2 details the NAMUR option.
- 1.2 Operate the actuator to the fully closed position.

1.3 Direct mount

- 1.3a Before mounting the AVID LP it will be necessary to remove the cover.
- 1.3b To do this, loosen the 4 off M5 captive screws with either a 8 mm A/F spanner / socket drive or an appropriately sized flat blade screwdriver.
- 1.3c Remove the cover assembly by lifting the cover vertically. Keep the cover safe taking care not to damage the cover seal detail.

Figure 1

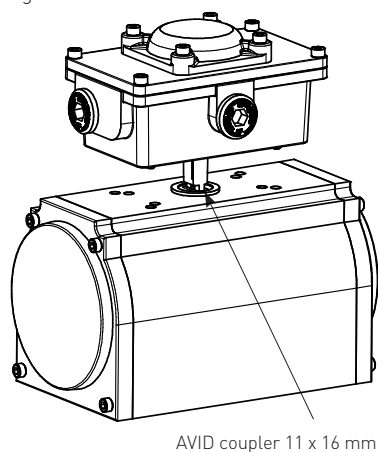

- 1.3d Mount the AVID LP switchbox to the actuator by aligning the 11 x 16 mm shaft adaptor to the actuator pinion coupler.
- 1.3e Ensure that the base of the AVID LP housing sits flush with the top of the actuator.
- 1.3f Locate and tighten the 4 off M5 captive screws in the base of the housing with either a 8 mm A/F socket drive or an appropriately sized flat blade screwdriver.
- 1.3g Tighten the screws to a torque value of 18 to 22 Lb/Ins.

1.4 NAMUR Mount

NOTE

Due to the mounting hole pattern of the AVID LP housing being 93.5 x 41.3 mm equal about the center of the shaft, a modified Namur bracket is required. The modification can either be 4 off M5 tapped holes or 4 off M5 clearance holes.

- 1.4a Secure the appropriately sized modified Namur bracket to the actuator using the screws / washers supplied with the Namur kit finger tight only.
- 1.4b(1) For mounting brackets with 4 off M5 tapped holes, mount the LP switchbox to the mounting bracket by engaging the Namur shaft drive into the actuator Namur pinion slot.

Figure 2

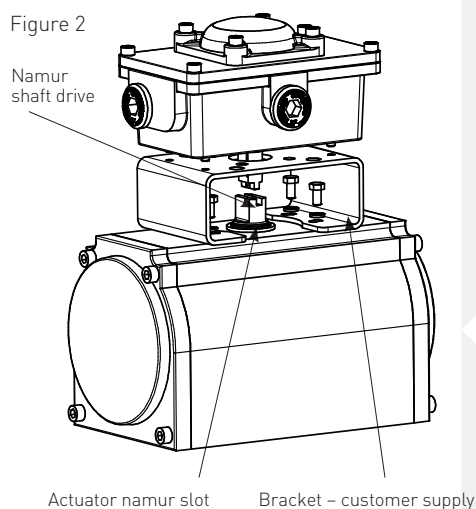

- 1.4b(2) Locate and tighten the 4 off M5 captive screws in the base of the housing with either a 8 mm A/F spanner / socket drive or an appropriately sized flat blade screwdriver.
- 1.4b(3) Tighten the screws to a torque value of 18 to 22 Lb/Ins.
- 1.4c(1) For mounting brackets that have 4 off M5 clearance holes it will be necessary to replace the 4 off M5 captive LP housing mounting screws with M5 x 16 mm screws to be sealed with new sealing caps.
- 1.4c(2) Tighten the screws to a torque value of 18 to 22 Lb/Ins.

AVID LP R2

INSTALLATION AND OPERATING INSTRUCTIONS

3.0 FIELD WIRING

ATTENTION

Before installing the conduit entry gland, please ensure that it is the correct size and thread form. An incorrect gland may affect the enclosure ingress protection rating.

- 3.1 The terminal strip base has been designed to offer easy access for wire termination.
- 3.1a It is not necessary to remove the terminal strip to connect the field wiring, but if required, first remove the terminal strip retaining screw and keep safe as this will be required to secure the terminal strip when complete.
- 3.1b Lift the terminal strip evenly off of the two base pins and terminate the wiring in accordance with the wiring diagram which is located on the of the cover.

NOTE

For special builds of the AVID LP product it may be necessary to have an additional A4 wiring diagram placed in the packing box.

- 3.1c Position the terminal strip over the two base pins and press evenly in the direction of the pins.
- 3.1d Secure with the retaining screw removed in step 3.1a.

4.0 EASIFIX CAM SETTING

- 4.1 To set the switch or sensor cam (Fig. 3), lift the bottom cam and turn until switch / sensor is activated and then release. The spring will push the cam back onto the splined shaft.
- 4.2 Operate the actuator to the opposite extreme, push down on the top cam and turn until the upper switch / sensor is activated.
- 4.3 Operate the actuator from one extreme to the other several times to ensure that the switches / sensors activate correctly.

5.0 COVER ASSEMBLY

- 5.1 Before assembling the cover assembly to the AVID LP housing, check the cover seal detail to ensure that it is not damaged and free of debris.
- 5.1 Engage the shaft into the beacon bore and rotate the cover assembly so that the shaft drive flats fully engage.
- 5.2 Approximately align the cover with the housing flange and secure using either a 8 mm A/F spanner / socket drive or an appropriately sized flat blade screwdriver.
- 5.3 Tighten the screws to a torque value of 18 to 22 Lb/Ins.

6.0 READY FOR USE

- 6.1 The AVID LP switchbox is now ready for use.
- 6.2 If there are any un-used conduit entries, please ensure that they are plugged using correctly rated IP blanking plugs.

7.0 TECHNICAL DATA

Area classification - non hazardous.
Ingress protection - IP66 / 67

Switch / sensor options

Mechanical Switch – SPDT Form C,
Electrical rating -
24, 48, 110 & 240 VAC / 15Amps,
24 VDC / 15 Amps
48 VDC / 2.5 Amps

Alternative inductive proximity sensors;

P&F - NJ2-V3-N, NBB3-V3-Z4, NBB2-V3-E2
IFM - IS5026, IS5001, IS0003, IS5003, NS5002
Turck - Bi2-Q10S-AP6X, Bi2-Q10S-Y0X
Telemecanique - XS7-H10PA340

Terminal strip –
Weco 302 HDS, 8 points or Klippon MK3,
6 points.
Conduit options –
Up to 2 x M20 x 1.5p or 1/2" -14 NPT
Ambient Temperature Range –
Minus 20°C to +80°C

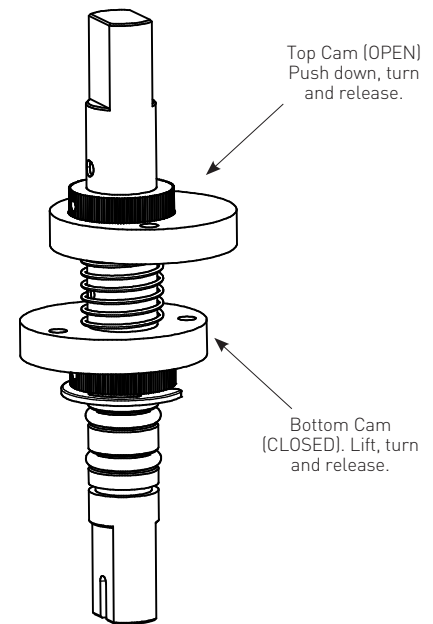

Figure 3

AVID LP R2

INSTALLATION AND OPERATING INSTRUCTIONS

NOTE

For AVID LP switchbox wiring diagrams, please visit www.pentair.com

PARTS LIST

Item	Qty	Description
1	1	LP B/W Cover assembly
2	1	LP Shaft assembly
3	1	LP Housing assembly 2 x M20
4	1	8pt Terminal Strip
5	1	LP Shaft coupler
6	1	Terminal stool
7	1	Housing / Cover Gasket
8	1	Internal earth 8-32 UNC
9	1	E'Clip
10	2	Switch screws
11	1	Terminal securing screw
12	1	Terminal stool securing screw
13	1	Shaft coupler securing screw
14	2	IP Blanking plug
15	1	Internal earth washer
16	1	Switch spacer
17	1	Switch stabilizing plate
18	1	Top switch
19	1	Bottom switch

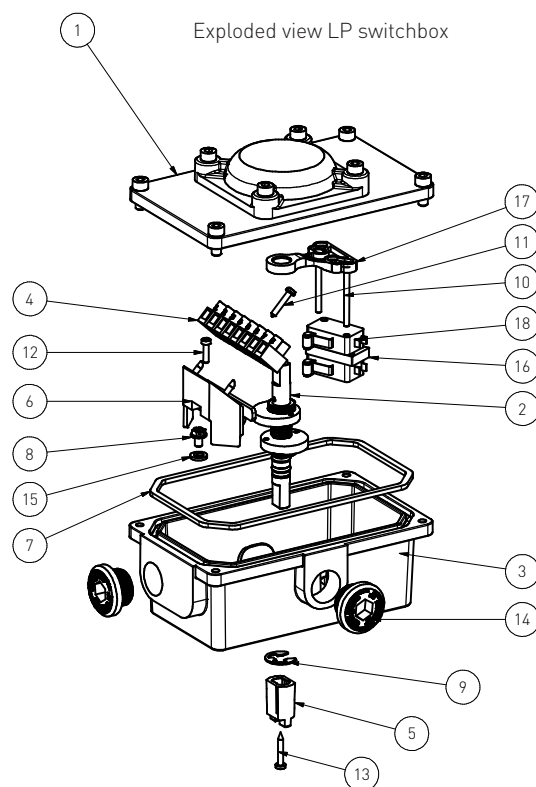

OVERALL DIMENSIONS (mm)

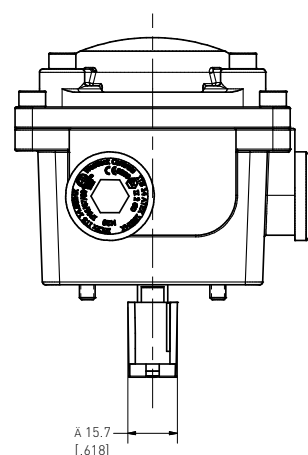
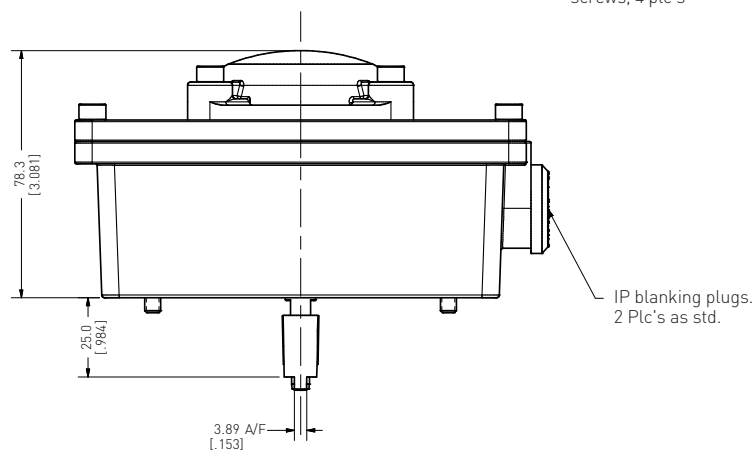
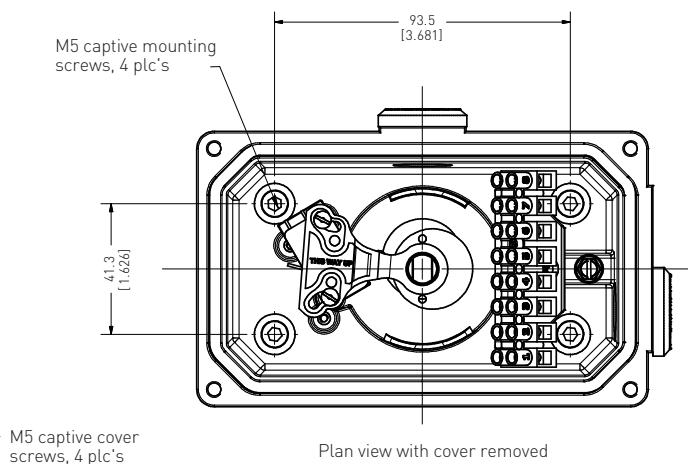
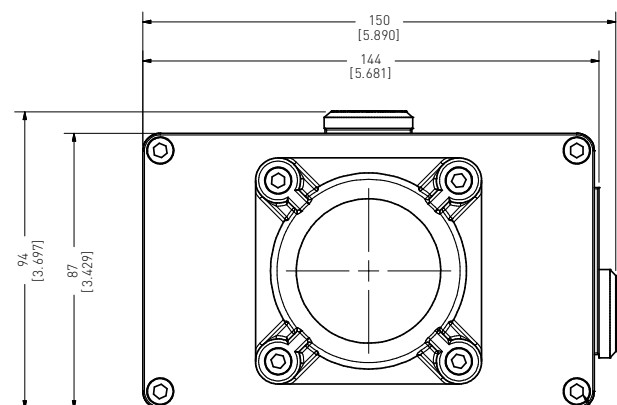

These installation and operating instructions are based on document TECHUK-74 specifically for the LP unit.