

EMERGENCY HANDWHEEL (OPTIONAL)

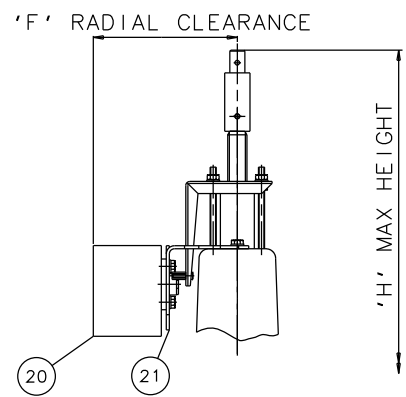

'007' SWITCHBOX (OPTIONAL)

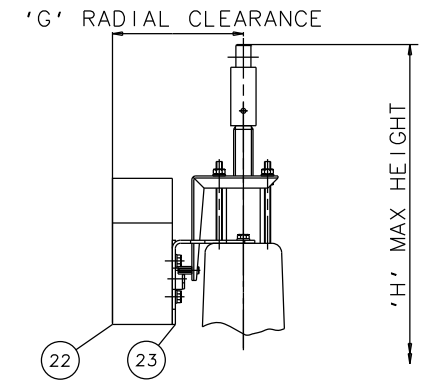

VIAPOS-MIDI POSITIONER (OPTIONAL)

Item	Component	Material	lining
1	HANDWHEEL SPINDLE	MILD STEEL	
2	UPPER SPRING PLATE	MILD STEEL	
3	SPRING	MILD STEEL	
4	SPRING COVER	SILICON ALUM.	
5	BUSH/CYL. 'O' RING	RUBBER	
6	DIAPHRAGM PLATE	FORGED STEEL	
7	OPERATING DIAPHRAGM	RUBBER	
8	MASTER SPINDLE	STAINLESS STEEL	
9	BONNET	STEEL	
10	COMPRESSOR	STAINLESS STEEL	
11	LINE DIAPHRAGM	RUBBER/PTFE	
12	SPINDLE ATTACHMENT	STAINLESS STEEL	
13	UPPER CYLINDER	SILICON ALUM.	
14	LOWER CYLINDER	SILICON ALUM.	
15	HANDWHEEL	STEEL	
16	BODY	CAST IRON	GLASS
17	LOWER SPRING PLATE	MILD STEEL	
18	FAIRCHILD REGULATOR		
19	MOUNTING BRACKET	STAINLESS STEEL	
20	'007' SWITCHBOX		
21	MOUNTING BRACKET	STAINLESS STEEL	
22	VIAPOS MIDI POSITIONER		
23	MOUNTING BRACKET	STAINLESS STEEL	

Size(DN)	A	B	C	D	E	F	G	H
50	796	190	230	827	780	142	152	850
65	815	216	290	846	800	142	152	867
80	842	254	310	873	823	142	152	898
100	860	305	350	891	842	142	152	923

The information on this sheet is Private and Confidential and is the property of Crane Process Flow Technologies Limited and must not be published directly or indirectly in any manner whatsoever without the written permission of the Company and must not be used in any way detrimental to their interests.
 © Crane Process Flow Technologies

CRANE Process Flow Technologies
A Crane Co. Company

Saunders
The Science Inside

Title
 GENERAL ARRANGEMENT OF 'KB' TYPE ES70 SPRING OPENING MODULAR ACTUATOR (D8000) COMPLETE WITH OPTIONS FITTED ON GLASS LINED FLANGED BODY

Drawn JRD	Date 23.09.14	UNCONTROLLED IN HARD COPY FORMAT	
Checked RND	Date 23.09.14		
First Angle Projection Method E	DO NOT SCALE	Drawing No. KB-ES70-GLASS	Issue. 1