

EMERGENCY HANDWHEEL
(OPTIONAL)

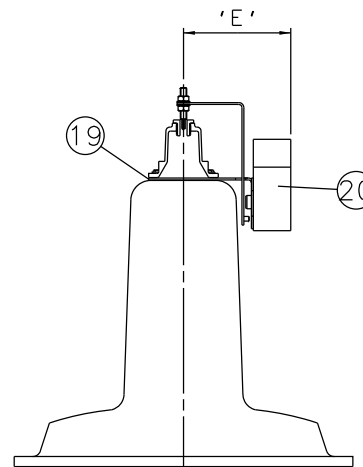

PMV POSITIONER
(OPTIONAL)

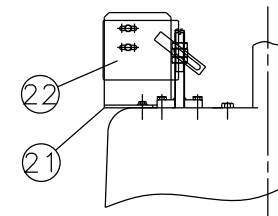

'007' SWITCHBOX
(OPTIONAL)

Item	Component	Material	Lining
1	ADJUSTING SCREW	MILD STEEL	
2	SPRING COVER	SILICON ALUMINIUM	
3	INDICATOR ROD	STAINLESS STEEL	
4	LIFTING ROD	MILD STEEL	
5	UPPER SPRING PLATE	S.G. IRON	
6	SPRING	SPRING STEEL	
7	LOWER SPRING PLATE	S.G. IRON	
8	DIAPHRAGM PLATE	CAST IRON	
9	LOWER CYLINDER O RING	RUBBER	
10	MASTER SPINDLE	STAINLESS STEEL	
11	BONNET	CAST IRON	
12	SPINDLE ATTACHMENT	STAINLESS STEEL	
13	COMPRESSOR	CAST IRON	
14	LINE DIAPHRAGM	RUBBER	
15	BODY	CAST IRON	HARD RUBBER
			SOFT RUBBER
			BUTYL RUBBER
			NEOPRENE RUBBER
16	COVER	SILICON ALUM.	
17	OPERATING DIAPHRAGM	RUBBER	
18	LOWER CYLINDER	SILICON ALUM.	
19	MOUNTING BRACKET	STAINLESS STEEL	
20	VIAPOS MIDI POSITIONER		
21	MOUNTING BRACKET	STAINLESS STEEL	
22	007 SWITCHBOX		
23	HANDWHEEL	CAST IRON	

Size(DN)	A	B	C	D	E
100	1079	305	350	1221	204
125	1092	356	400	1234	204
150	1158	406	480	1300	204

The information on this sheet is Private and Confidential and is the property of Crane Process Flow Technologies Limited and must not be published directly or indirectly in any manner whatsoever without the written permission of the Company and must not be used in any way detrimental to their interests.
© Crane Process Flow Technologies

CRANE Process Flow Technologies
A Crane Co. Company

Saunders
The Science Inside

Title

GENERAL ARRANGEMENT OF 'KB' TYPE ES65 SPRING CLOSING MODULAR ACTUATOR (F8400) COMPLETE WITH OPTIONS FITTED ON RUBBER LINED FLANGED BODY

Drawn JRD Date 16.09.14

Checked RND Date 16.09.14

First Angle Projection Method E

UNCONTROLLED IN HARD COPY FORMAT

Drawing No. KB-ES65-RUBBER Issue. 1