

EMERGENCY HANDWHEEL
(OPTIONAL)

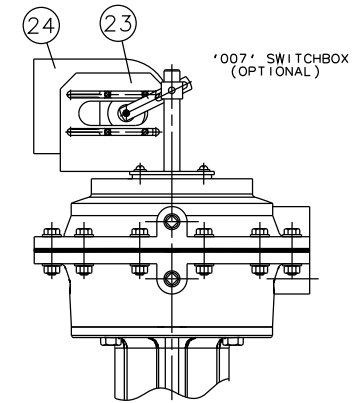
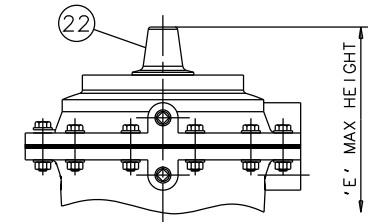

Item	Component	Material						
1	UPPER CYLINDER	SILICON ALUM.						
2	UPPER DIAPHRAGM PLATE	MILD STEEL						
3	LOWER DIAPHRAGM PLATE	MILD STEEL						
4	OPERATING DIAPHRAGM	RUBBER						
5	LOWER CYLINDER	SILICON ALUM.						
6	CYLINDER 'O' RING	RUBBER						
7	MASTER SPINDLE	STAINLESS STEEL						
8	SPINDLE ATTACHEMENT	STAINLESS STEEL						
9	BONNET	CAST IRON						
10	COMPRESSOR	CAST IRON						
11	LINE DIAPHRAGM	RUBBER						
12	BODY	CAST IRON GUNMETAL						
13	HANDWHEEL	PRESSED STEEL						
14	HANDWHEEL SPINDLE	MILD STEEL						
15	SPINDLE BUSH	MILD STEEL						
16	INDICATOR ROD	MILD STEEL						
17	COVER	SILICON ALUM.						
18	UPPER SPRING PLATE	MILD STEEL	Size(DN)	A	B	C	D	E
19	GUIDE ROD	MILD STEEL	25	282	111	664	635	358
20	SEALING PLATE	MILD STEEL						
21	SEALING PLT. 'O' RING	RUBBER	32	282	124	664	635	358
22	INDICATOR COVER	POLAMIDE	40	282	143	664	635	358
23	MOUNTING BRACKET	STAINLESS STEEL						
24	'007' SWITCHBOX		50	290	168	611	565	364

The information on this sheet is Private and Confidential and is the property of Crane Process Flow Technologies Limited and must not be published directly or indirectly in any manner whatsoever without the written permission of the Company and must not be used in any way detrimental to their interests.
© Crane Process Flow Technologies

CRANE Process Flow Technologies
A Crane Co. Company

Saunders
The Science Inside

Title

GENERAL ARRANGEMENT OF 'KB' TYPE ES55 DOUBLE ACTING MODULAR ACTUATOR (C8200) COMPLETE WITH OPTIONS FITTED ON SCREWED BODY

Drawn RI Date 31.07.14

UNCONTROLLED IN
HARD COPY FORMAT

Checked RND Date 31.07.14

First Angle Projection Method E

Drawing No. Issue.
KB-ES55-SCREWED 1