

25mm - 50mm

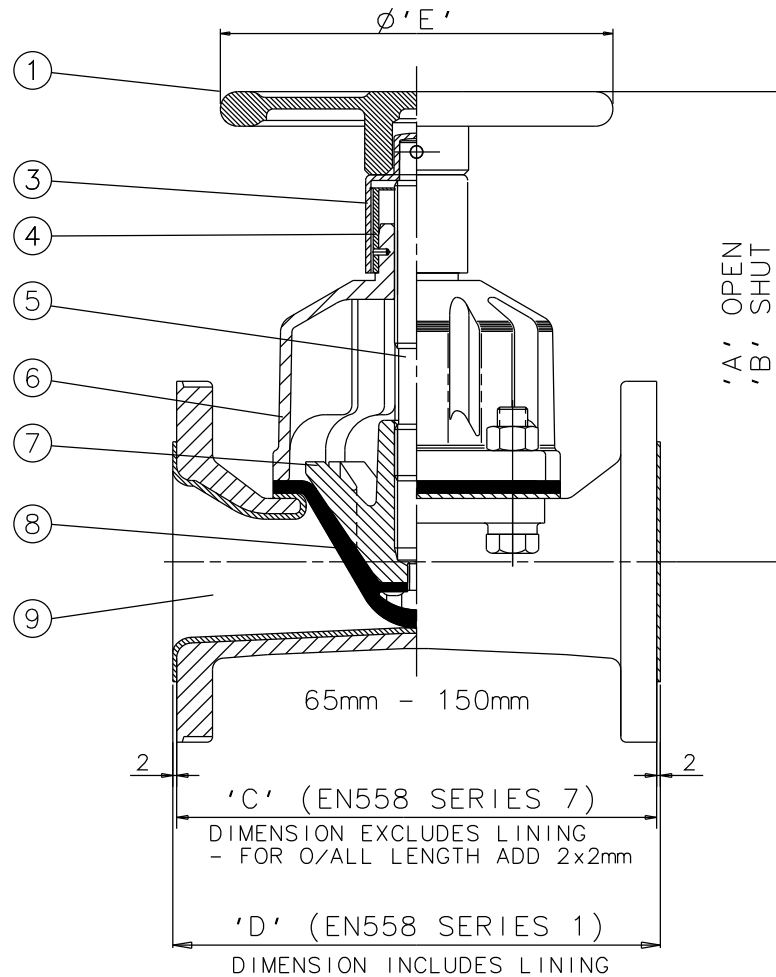

Item	Component	Material	Lining	Where Used
1	HANDWHEEL	CAST IRON		25-50mm
2		ABS		
3	HANDWHEEL BOSS	POLYPROPYLENE		
4	BONNET SLEEVE	POLYPROPYLENE		
5	SPINDLE	MILD STEEL		
6	BONNET	CAST IRON		
7	COMPRESSOR	CAST IRON		
8	LINE DIAPHRAGM	RUBBER		
9	BODY	CAST IRON	HARD RUBBER	
			SOFT RUBBER	
		SG IRON	BUTYL RUBBER	
			NEOPRENE RUBBER	

Size(DN)	A	B	C	D	E
15	N/A				
20	N/A				
25	168	162	127	160	120
32	168	162	146	180	120
40	168	162	159	200	120
50	179	159	190	230	120
65	237	213	216	290	170
80	273	241	254	310	230
100	316	280	305	350	280
125	338	296	356	400	280
150	438	382	406	480	368

The information on this sheet is Private and Confidential and is the property of Crane Process Flow Technologies Limited and must not be published directly or indirectly in any manner whatsoever without the written permission of the Company and must not be used in any way detrimental to their interests.
 © Crane Process Flow Technologies

CRANE Process Flow Technologies
A Crane Co. Company

Saunders
The Science Inside

Title
 GENERAL ARRANGEMENT OF 'KB' TYPE RISING
 HANDWHEEL INDICATOR BONNET ASSEMBLY (9000)
 FITTED ON RUBBER LINED FLANGED BODY

Drawn RI	Date 30.06.14	UNCONTROLLED IN HARD COPY FORMAT
Checked RND	Date 30.06.14	
First Angle Projection Method E	DO NOT SCALE	Drawing No. KB-CI-RHI-RUBBER
		Issue. 1