

DN200

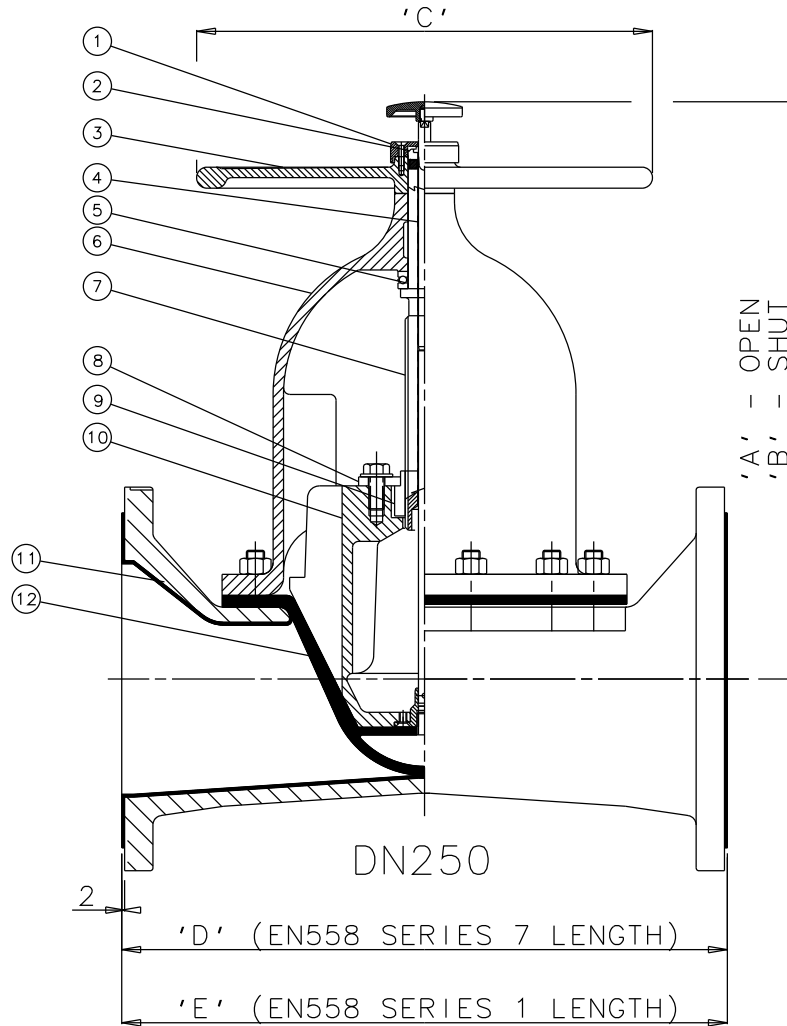

DN250

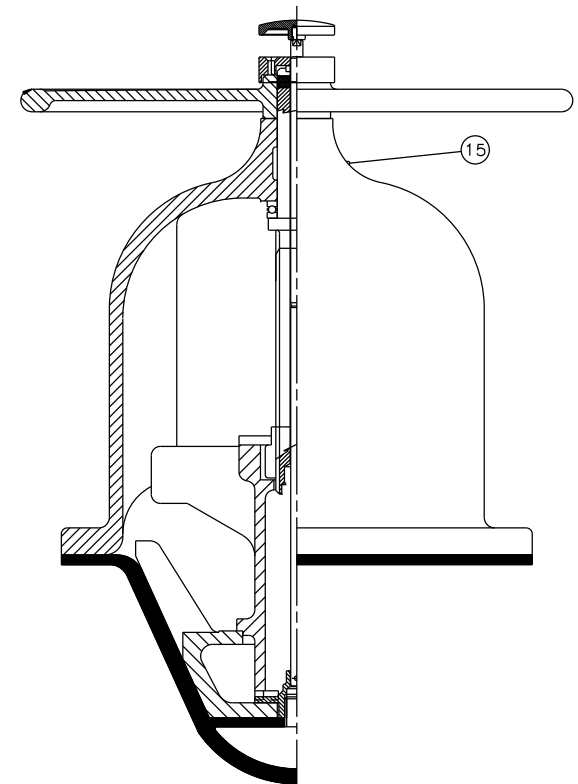

DN300

Item	Component	Material	Lining
1	HANDWHEEL COVER PLATE	STEEL	
2	WIPER SEAL	NITRILE	
3	HANDWHEEL	CAST IRON	
4	INDICATOR ROD	STAINLESS STEEL	
5	THRUST RACE		
6	BONNET	CAST IRON	
7	SPINDLE	STEEL	
8	COMPRESSOR PLATE	S.G. IRON	
9	SPINDLE NUT	BRONZE	
10	COMPRESSOR	CAST IRON	
11	BODY	CAST IRON	HARD RUBBER
			SOFT RUBBER
			BUTYL RUBBER
			NEOPRENE RUBBER
12	LINE DIAPHRAGM	RUBBER	
13	HANDWHEEL	STEEL	
14	SPINDLE NUT	BRASS	
15	GREASE NIPPLE		

Size (DN)	A	B	C	D	E
200	597	476	400	525	600
250	795	612	483	639	730
300	891	683	584	753	850

The information on this sheet is Private and Confidential and is the property of Crane Process Flow Technologies Limited and must not be published directly or indirectly in any manner whatsoever without the written permission of the Company and must not be used in any way detrimental to their interests.

Crane Process Flow Technologies



Process Flow Technologies
A Crane Co. Company



Title			
GENERAL ARRANGEMENT OF 'KB' TYPE NON RISING HANDWHEEL INDICATOR BONNET ASSEMBLY (1050) FITTED ON RUBBER LINED FLANGED BODY.			
Drawn	NAW	Date 16.09.14	UNCONTROLLED IN HARD COPY FORMAT
Checked	RND	Date 16.09.14	
First Angle Projection Method E		DO NOT SCALE	Drawing No.
			Issue. 1