

XOMOX®

brands you trust.

TECHNICAL DATASHEET
XOMOX® FK Ball Valves
Type K21F - K23F



CRANE®

www.cranecpe.com

Xomox® FK Ball Valves Features and Benefits

Soft-Seated Ball Valves According to ASME Standards

Xomox FK Valves are designed in accordance with ASME B16.34, API-608, API-6D, these ball valves feature a full-port split body design, and the option of a locking hand lever or an enclosed operating gear and hand wheel. Each valve is tested to API 598 as standard.

FEATURES INCLUDE:

- Full bore design
- Face-to-face dimension Long Pattern ASME B16.10
- Raised Face Flange dimension per ASME B16.5
- Self-relieving seats
- Fire tested API 607 6th edition & ISO 10497:2010
- Anti-static design (electrical continuity between ball-stem-body)
- Blow-out proof stem
- Actuator mounting flange according to ISO 5211
- Patented SX stem seal for side load protection
- Fugitive emissions per EPA Method-21, ISO-15848, & TA-Luft (VDI 2440)



Standard hand lever with locking device.

Scope of Supply

Class	Face-to-face Dimension	Dual-Certified Body Material
150	ASME B16.10	CF8M / 1.4408
300	ASME B16.10	CF8M / 1.4408
150	ASME B16.10	WCB / 1.0619
300	ASME B16.10	WCB / 1.0619

Class 150 & 300 Floating Ball Design Dimensions and Weights

K21F DN15-200 CL150
K23F DN15-200 CL300

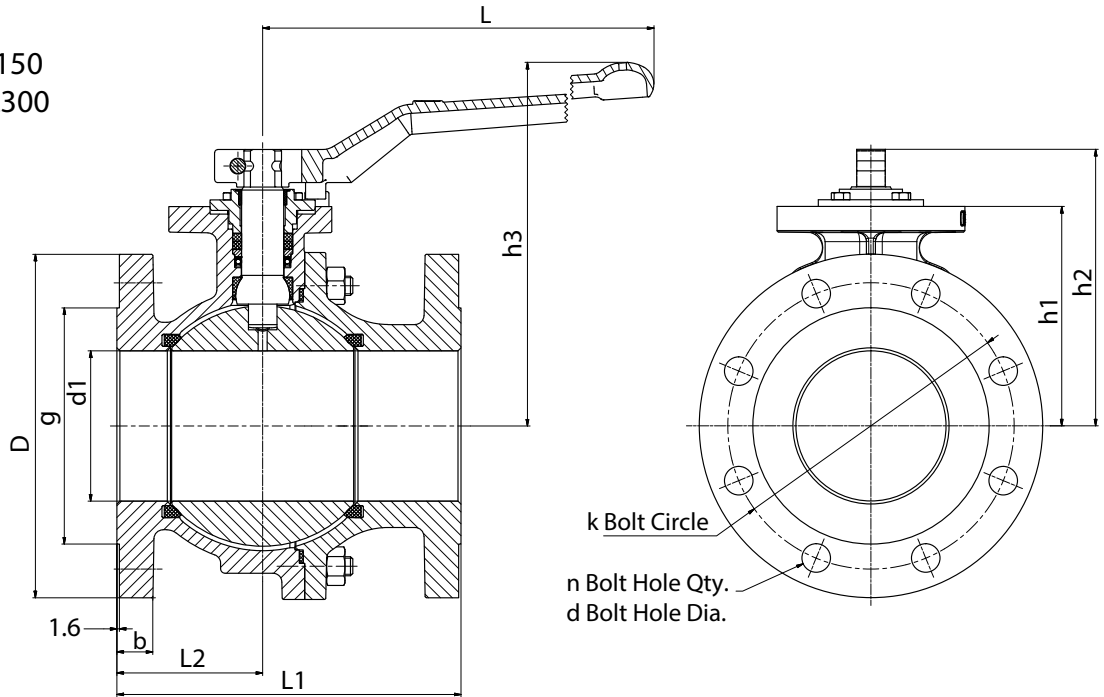

CLASS 150 (mm)

DN	Size	L1	L2	b	D Dia.	k Bolt Circle Dia.	n Bolt Hole Qty.	d Bolt Hole Dia.	g Dia.	d1 Dia.	ISO 5211 Pattern	Thread	h1	h2	h3	L	Bare Stem Weight kg
15	1/2"	108	46	11.3	89.0	60.5	4	15.9	34.9	15	F05	M6	48	69	98	182	2.4
20	3/4"	117	50	12.7	98.6	69.9	4	15.9	42.9	20	F05	M6	53	74	102	182	2.9
25	1"	127	52	14.3	108.0	79.2	4	15.9	50.8	25	F05	M6	58	78	107	182	3.6
40	1 1/2"	165	71	17.5	127.0	98.6	4	15.9	73.0	38	F07	M8	82	110	151	280	8.0
50	2"	178	74	19.1	152.4	120.7	4	19.0	92.1	50	F07	M8	90	118	158	280	10.5
80	3"	203	86	23.9	190.5	152.4	4	19.0	127.0	78	F10	M10	127	165	223	450	23.2
100	4"	229	97	23.9	228.6	190.5	8	19.0	157.2	100	F10	M10	146	184	242	450	33.8
150	6"	394	197	25.5	279.4	241.3	8	22.2	215.9	151	F14	M16	212	260	323	720	97.8
200	8"	457	225	28.5	343.0	298.4	8	22.2	269.9	202	F14	M16	257	351	n/a	n/a	169.0

CLASS 300 (mm)

DN	Size	L1	L2	b	D Dia.	k Bolt Circle Dia.	n Bolt Hole Qty.	d Bolt Hole Dia.	g Dia.	d1 Dia.	ISO 5211 Pattern	Thread	h1	h2	h3	L	Bare Stem Weight kg
15	1/2"	140	52	14.3	95.2	66.7	4	15.9	34.9	15	F05	M6	48	69	98	182	3.2
20	3/4"	152	54	15.7	117.3	82.6	4	19.0	42.9	20	F05	M6	53	74	102	182	4.4
25	1"	165	58	17.4	124.0	88.9	4	19.0	50.8	25	F05	M6	58	78	107	182	5.1
40	1 1/2"	190	76	20.7	155.4	114.3	4	22.2	73.0	40	F07	M8	82	110	151	280	11.2
50	2"	216	81	22.3	165.0	127.0	8	19.0	92.1	50	F07	M8	90	118	158	280	13.4
80	3"	282	99	28.4	209.6	168.2	8	22.2	127.0	80	F10	M10	127	165	223	450	30.6
100	4"	305	112	31.8	254.0	200.2	8	22.2	157.2	100	F10	M10	146	184	242	450	49.2
150	6"	403	202	36.6	317.5	269.7	12	22.2	215.9	151	F14	M16	212	264	n/a	n/a	137.0
200	8"	502	251	41.1	381.0	330.2	12	25.4	269.9	202	F16	M20	256	367	n/a	n/a	234.0

For actuation dimensions see pages 8 and 9.

Class 150 & 300 Trunnion Ball Design Dimensions and Weights

K21F-T DN250-300 CL150

K23F-T DN250-300 CL300

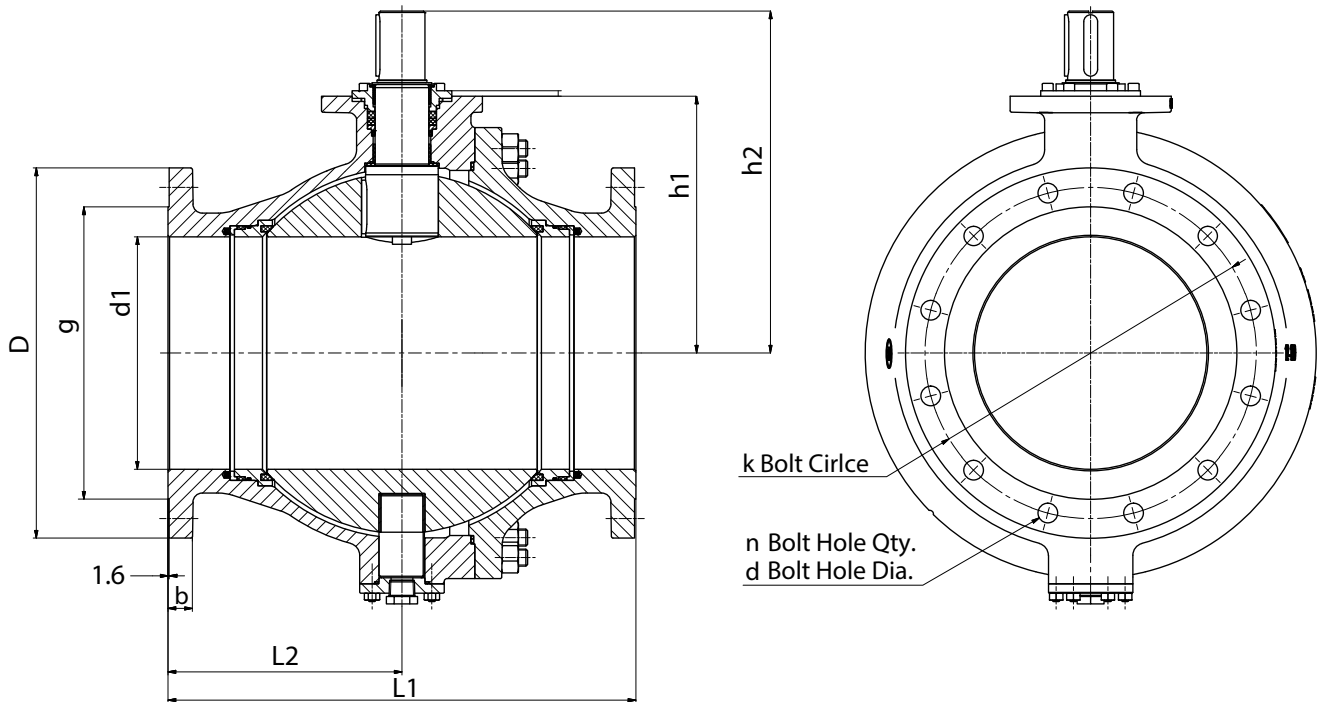

CLASS 150 (mm)

DN	Size	L1	L2	b	D Dia.	k Bolt Circle Dia.	n Bolt Hole Qty.	d Bolt Hole Dia.	g Dia.	d1 Dia.	ISO 5211 Pattern	Thread	h1	h2	Bare Stem Weight kg
250	10"	533	222	302.0	406.4	362.0	12	25.4	323.8	252	F14	M16	300	394	278
300	12"	610	305	31.8	482.4	431.8	12	25.4	381.0	303	F16	M20	335	446	460

CLASS 300 (mm)

DN	Size	L1	L2	b	D Dia.	k Bolt Circle Dia.	n Bolt Hole Qty.	d Bolt Hole Dia.	g Dia.	d1 Dia.	ISO 5211 Pattern	Thread	h1	h2	Bare Stem Weight kg
250	10"	568	238	47.7	445	387.4	16	28.6	323.8	252	F16	M20	285	396	379
300	12"	648	324	50.8	521	450.8	16	31.8	381.0	303	F25	M16	335	478	594

For actuation dimensions see pages 8 and 9.

Floating Ball Design Materials of Construction

K21F DN15-80 CL150
K23F DN15-80 CL300

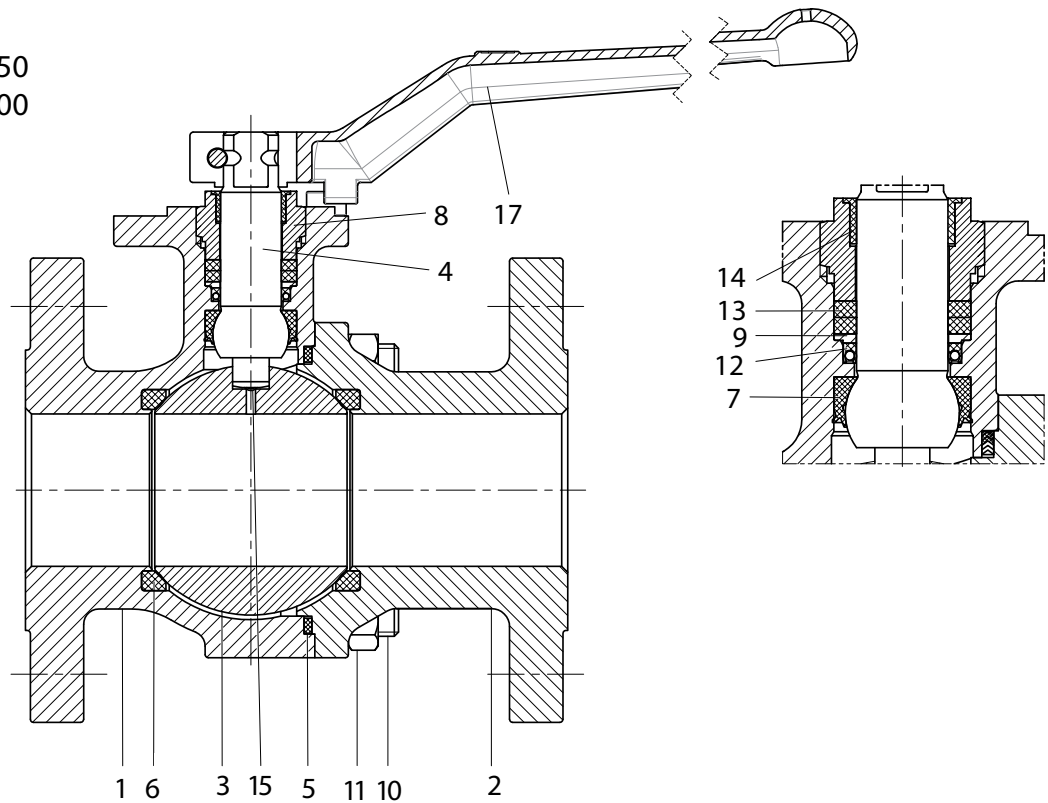

Item	Description	Carbon Steel	Stainless Steel
1	Body	(1.0619) ASTM A216 Gr WCB	(1.4408) ASTM A351 Gr. CF8M
2	Tail	(1.0619) ASTM A216 Gr WCB	(1.4408) ASTM A351 Gr. CF8M
3	Ball	316ss	316ss
4	Stem	UNS S31803	UNS S31803
5	Body Gasket	PTFE/Graphite/316ss	PTFE/Graphite/316ss
6	Seat	TFM	TFM
7	SX Stem Seal	TFM	TFM
8	Packing Gland	UNS S31803	UNS S31803
9	Support Ring	316ss	316ss
10	Stud	ASTM A193 Gr. B7	ASTM A193 Gr. B8M Cl.2
11	Heavy hex nut	ASTM A194 Gr. 2H	ASTM A194 Gr. 8M
12	Spring energized Lip Seal	PTFE Filled/SST	PTFE Filled/SST
13	Packing	Graphite	Graphite
14	Guide bushing	PTFE-Carbon filled	PTFE-Carbon filled
15	Anti-static spring	SST	SST
*16	Stop Pin	316ss	316ss
17	Hand lever	316ss	316ss
*18	Socket Head Cap Screw	316ss	316ss
*19	Hex Nut	316ss	316ss
*20	Locking pin with Ring	316ss	316ss

*not shown

Floating Ball Design Materials of Construction

K21F DN100-200 CL150
K23F DN100-200 CL300

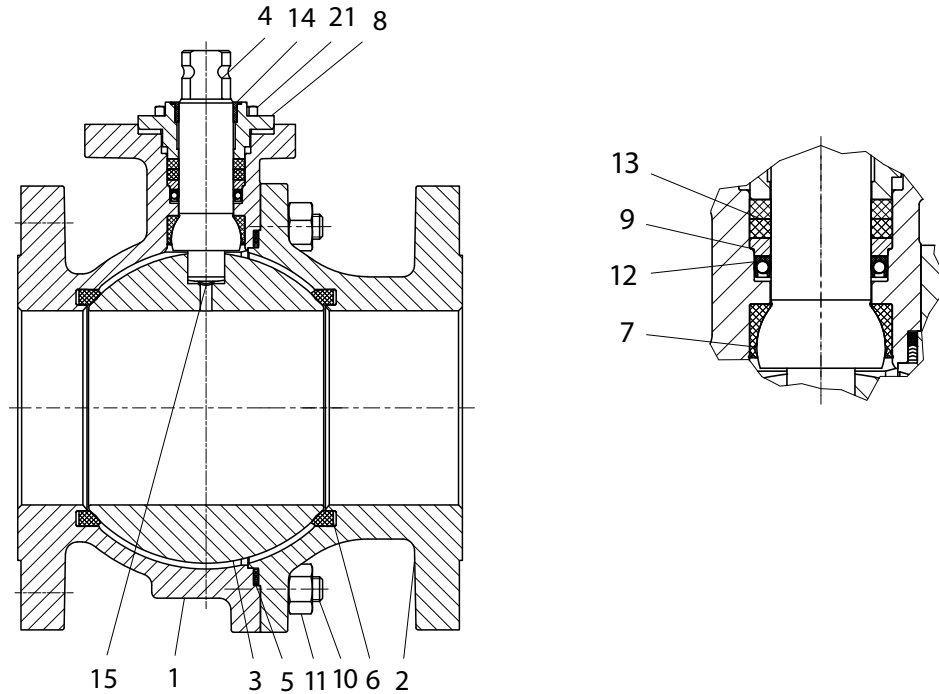

Item	Description	Carbon Steel	Stainless Steel
1	Body	(1.0619) ASTM A216 Gr WCB	(1.4408) ASTM A351 Gr. CF8M
2	Tail	(1.0619) ASTM A216 Gr WCB	(1.4408) ASTM A351 Gr. CF8M
3	Ball	316ss	316ss
4	Stem	UNS S31803	UNS S31803
5	Body Gasket	PTFE/Graphite/316ss	PTFE/Graphite/316ss
6	Seat	TFM	TFM
7	SX Stem Seal	TFM	TFM
8	Packing Gland	316ss	316ss
9	Support Ring	316ss	316ss
10	Stud	ASTM A193 Gr. B7	ASTM A193 Gr. B8M Cl.2
11	Heavy hex nut	ASTM A194 Gr. 2H	ASTM A194 Gr. 8M
12	Spring energized Lip Seal	PTFE Filled/SST	PTFE Filled/SST
13	Packing	Graphite	Graphite
14	Guide bushing	PTFE-Carbon filled	PTFE-Carbon filled
15	Anti-static spring	SST	SST
*16	Stop Pin	316ss	316ss
*17	Hand lever	316ss	316ss
*18	Socket Head Cap Screw	316ss	316ss
*19	Hex nut	316ss	316ss
*20	Locking pin with ring	316ss	316ss
21	Packing Adjustment Bolt	ASTM A193 Gr. B8M Cl.2	ASTM A193 Gr. B8M Cl.2

*Not shown

Trunnion Ball Design Materials of Construction

K21F-T DN250-300 CL150
 K23F-T DN250-300 CL300

Detail view of seat

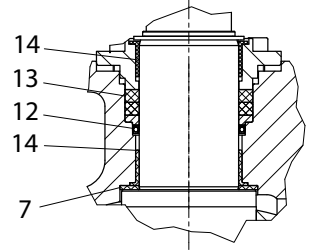
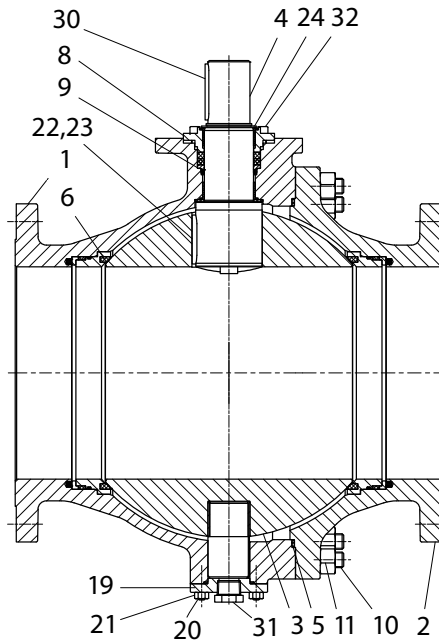
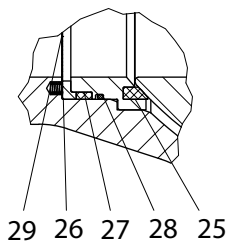

Detail view of top stem

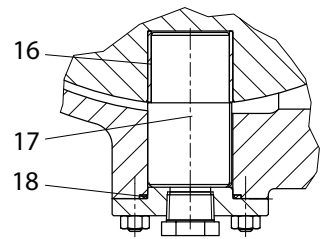

Detail view of bottom stem

Item	Description	Carbon Steel	Stainless Steel
1	Body	(1.0619) ASTM A216 Gr WCB	(1.4408) ASTM A351 Gr. CF8M
2	Tail	(1.0619) ASTM A216 Gr WCB	(1.4408) ASTM A351 Gr. CF8M
3	Ball	316ss	316ss
4	Stem	UNS S31803	UNS S31803
5	Body Gasket	PTFE/Graphite/316ss	PTFE/Graphite/316ss
6	Seat	TFM	TFM
7	Stem Seal	TFM	TFM
8	Packing Gland	316ss	316ss
9	Support Ring	316ss	316ss
10	Stud	ASTM A193 Gr. B7	ASTM A193 Gr. B8M Cl.2
11	Heavy hex nut	ASTM A194 Gr. 2H	ASTM A194 Gr. 8M
12	Spring energized Lip Seal	PTFE Filled/SST	PTFE Filled/SST
13	Packing	Graphite	Graphite
14	Flange bearing	Reinforced Thermoplastic	Reinforced Thermoplastic
16	Sleeve bearing	Reinforced Thermoplastic	Reinforced Thermoplastic
17	Bottom Stem	316ss	316ss
18	Gasket	PTFE/Graphite/316ss	PTFE/Graphite/316ss
19	Cover	ASTM A105	316ss
20	Stud	ASTM A193 Gr. B7	A193 Gr. B8M Cl.2
21	Heavy hex nut	ASTM A194 Gr.2H	A194 Gr. 8M
22	Parallel key	316ss	316ss
23*	Socket Head Cap Screw	316ss	316ss
24	Retaining ring	SST	SST
25	Seat Retaining ring	316ss	316ss
26	L-Ring	316ss	316ss
27	Seal Ring	Graphite	Graphite
28	O-Ring	Viton	Viton
29	Spring	SST	SST
30	Parallel Key	316ss	316ss
31	Pipe plug	316ss	316ss
32	Packing Adjustment Bolt	ASTM A193 Gr. B8M Cl.2	ASTM A193 Gr. B8M Cl.2

* Not shown, only used on 12" CL300, K23F-T

Actuator Mounting Dimensions

Figure 1

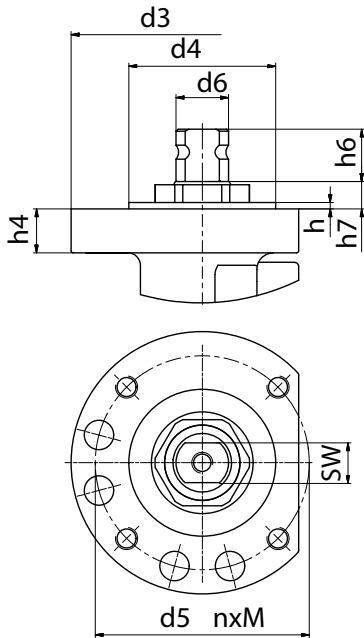

Figure 2

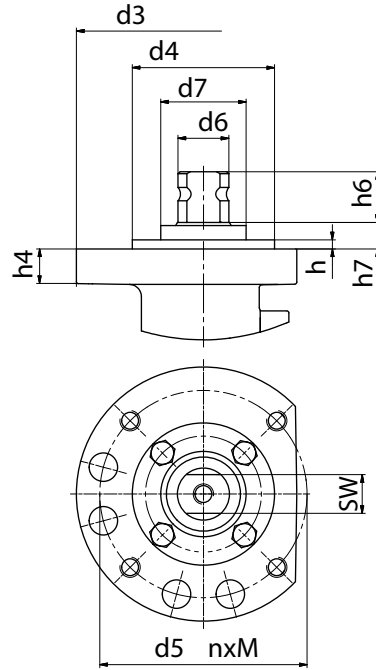

Figure 3

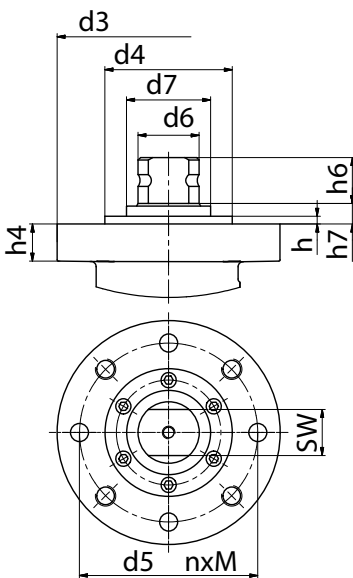

Figure 4

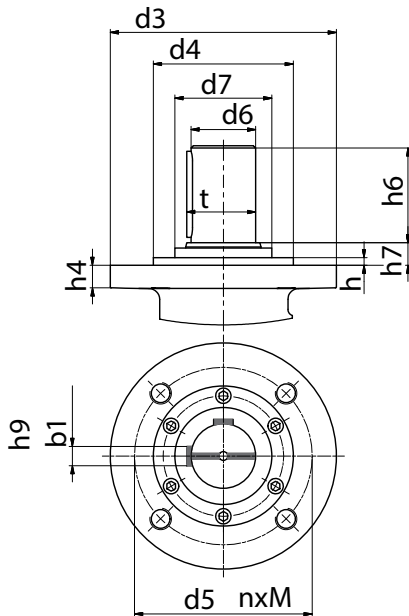
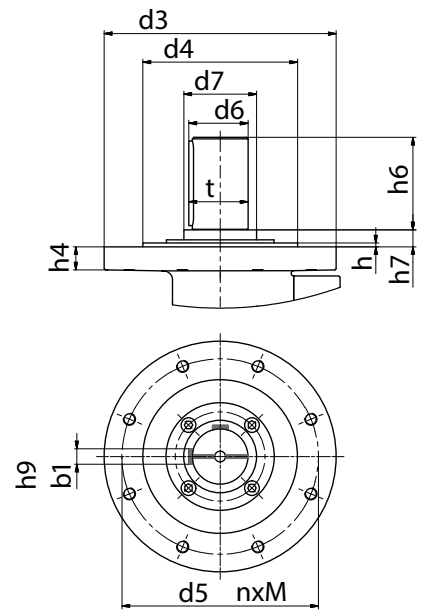

Figure 5



Actuator Mounting Dimensions

Dimensions (mm)

DN	Size	Class	Figure	ISO 5211 Mounting Dimension										Stem end connection			
				ISO 5211	d3	d5 (Bolt Circle)	n Qty.	M	d4	SW	d6	h	d7		h4	h6	h7
15	½"	150/300	1	F05	65	50	4	M6	35	11	14	2	-	9	12	9	Double D
20	¾"	150/300	1	F05	65	50	4	M6	35	11	14	2	-	9	12	9	Double D
25	1"	150/300	1	F05	65	50	4	M6	35	11	14	2	-	9	12	9	Double D
40	1½"	150/300	1	F07	90	70	4	M8	55	14	18	3	-	8	18	10	Double D
50	2"	150/300	1	F07	90	70	4	M8	55	14	18	3	-	10	18	10	Double D
80	3"	150/300	1	F10	125	102	4	M10	70	19	25	3	-	21	25	13	Double D
100	4"	150/300	2	F10	125	102	4	M10	70	19	25	6	42	17	25	13	Double D
150	6"	150	3	F14	175	140	4	M16	100	27	36	7	59	22	32	16	Double D
150	6"	300	3	F14	175	140	4	M16	100	36	48	7	66	29	36	16	Double D
200	8"	150	4	F14	175	140	4	M16	100	-	48	8	66	17	76	18	2 Keys
200	8"	300	4	F16	210	165	4	M20	130	-	60	8	90	21	90	21	2 Keys
250	10"	150	4	F14	175	140	4	M16	100	-	48	8	66	22	78	16	2 Keys
250	10"	300	4	F16	210	165	4	M20	130	-	60	8	90	21	90	21	2 Keys
300	12"	150	4	F16	210	165	4	M20	130	-	60	8	90	21	90	21	2 Keys
300	12"	300	5	F25	300	254	8	M16	200	-	72	5	94	30	119.5	23	2 Keys

Keyway Dimensions - Actuator Mounting Figures 4 & 5 (mm)

DN	Size	Class	Figure	b1 Key	b1 Tolerance	h9 Keyway	h9 Tolerance	t Key Standout	Stem end connection
200	8"	150	4	14	-0.018 / -0.061	14	0 / -0.043	51.5	2 Keys
200	8"	300	4	18	-0.018 / -0.061	18	0 / -0.043	64	2 Keys
250	10"	150	4	14	-0.018 / -0.061	14	0 / -0.043	51.5	2 Keys
250	10"	300	4	18	-0.018 / -0.061	18	0 / -0.043	64	2 Keys
300	12"	150	4	18	-0.018 / -0.061	18	0 / -0.043	64	2 Keys
300	12"	300	5	20	-0.022 / -0.074	20	0 / -0.052	76.5	2 Keys

Valve Torque – Cv

Valve Torque: Nm

DN	15	20	25	40	50	80	100	150 CL150	150 CL300	200 CL150	200 CL300	250 CL150	250 CL300	300 CL150	300 CL300
Size	1/2"	3/4"	1"	1 1/2"	2"	3"	4"	6"	6"	8"	8"	10"	10"	12"	12"
Class 150	8	8	9	30	42	75	115	400	-	800	-	950	-	1600	-
Class 300	8	10	12	40	55	100	140	-	800	-	1900	-	1900	-	2900

Break torque at max. pressure drop for Lubricating Fluids in clear/clear service conditions (i.e. water, oil at 38°C)

IMPORTANT!! If Non-Lubrication medias (i.e. Gases, Benzine), slurry's or adhesive medias are used, increasing torque values have to be considered.

Torque Factors for Actuation:

Break = 100%

Run = 70%

Seat = 90%

Maxium Allowable Stem Torque: Nm

DN	15	20	25	40	50	80	100	150 CL150	150 CL300	200 CL150	200 CL300	250 CL150	250 CL300	300 CL150	300 CL300
Size	1/2"	3/4"	1"	1 1/2"	2"	3"	4"	6"	6"	8"	8"	10"	10"	12"	12"
Stem MAST	63	85	85	130	180	500	500	1600	3000	2400	4400	2400	4400	5400	8000

Cv Factors

DN	Size	Kv	Cv
15	1/2"	26	30
20	3/4"	48	55
25	1"	82	95
40	1-1/2"	225	260
50	2"	424	490
80	3"	1125	1300
100	4"	1903	2200
150	6"	4801	5550
200	8"	8737	10100
250	10"	14186	16400
300	12"	20933	24200

Pressure / Temperature Range

Maximum allowable pressure (Bar)
 (Based on standard TFM seats).

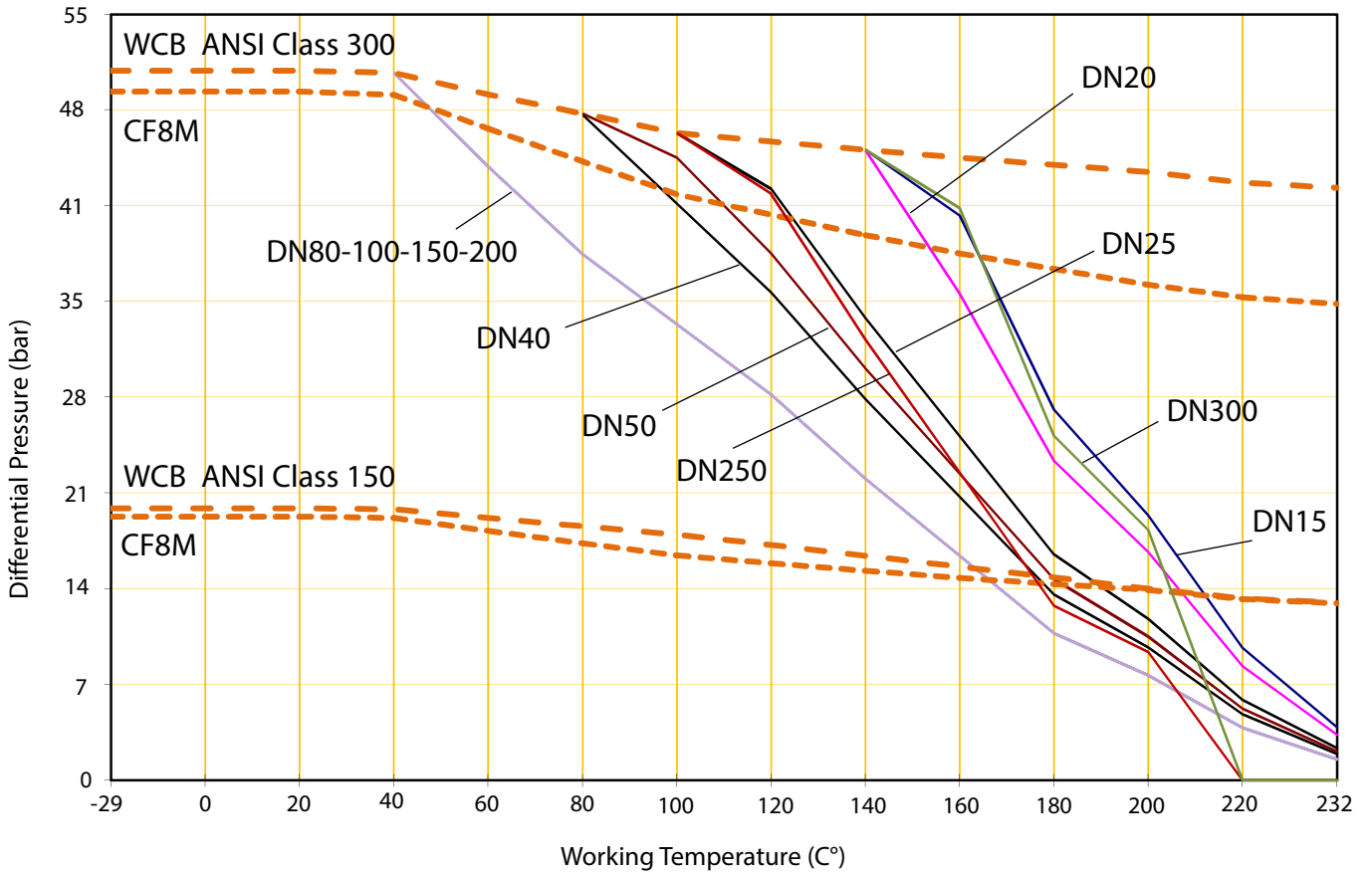

XOMOX®

CRANE ChemPharma & Energy

XOMOX® Headquarters
4444 Cooper Road,
Cincinnati, OH 45242, U.S.A.
Tel.: (513) 745-6000
Fax: (513) 745-6086
www.cranecpe.com



brands you trust.



COMPAC-NOZ®



DEPA®

ELRO®

DUO-CHEK®



NOZ-CHEK®



RESISTOFLEX®



Saunders®
the science inside

STOCKHAM®



UNI-CHEK®

w.ta.®

XOMOX®

CPE-XOMOX FK-SSBV-TD-A4-10-8-2014

Crane Co., and its subsidiaries cannot accept responsibility for possible errors in catalogues, brochures, other printed materials, and website information. Crane Co. reserves the right to alter its products without notice, including products already on order provided that such alteration can be made without changes being necessary in specifications already agreed unless otherwise indicated. All trademarks in this material are property of the Crane Co. or its subsidiaries. The Crane and Crane brands logotype (DEPA®, ELRO®, Krombach®, PSI®, Resistoflex®, ResistoPure™, Revo®, Saunders®, and XOMOX®) are registered trademarks of Crane Co. or its subsidiaries. All rights reserved.