

MOST COMPACT AUTOMATED SPV PACKAGES IN THE INDUSTRY

L-TORQ XOMOX
Sleeved Plug Valves

Why Sleeved Plug Valves



No Cavities

No scaling media
– Torque does not increase during service

Large Sealing Area

Small scratches do not affect the seal. No concern of leakage

Inline Adjustable

Inline and external seals can be adjusted while the valve is installed.

OUR HERITAGE EMBODIES TRUST AND CREATIVITY OUR FUTURE IS DEFINED THROUGH INNOVATION

**XOMOX® IS A PIONEER AND A REFERENCE MARKET
LEADER IN SLEEVED PLUG VALVE TECHNOLOGY
OUR PURPOSE IS TO PROVIDE YOU SOLUTIONS THAT
ENSURE SAFETY, QUALITY AND HIGH PERFORMANCE**

XOMOX® Sleeved Plug Valves

More than 65 years experience in variety of applications

- 1 Reliable shutoff and throttling service devices**
- 2 Provide safety in a wide range of severe and highly demanding services**
- 3 Show excellent performance in traditional ball and gate valve applications**
- 4 Offer a cost-efficient solution for tight shutoff and throttling of gases, vapors and slurries**

Product Overview

Materials of Construction

- WCB/CF8M/CN7M/CD4MCuN with PFA Sleeve

Size Range

- 1/2" - 6"

Pressure Ratings

- ASME Class 150, 300,

Sealing and Packing

- Cover Joint: 50% PTFE - 50% Graphite Spiral Wound Gasket with Monel or SS trim.
- Stem Seals: PTFE or Graphite per API 624

Actuator Mounting

- ISO 5211 Mounting

Applications

- MDI, TDI
- Fertilizer
- Ammonia
- Caustic
- Crude
- Oil Sands
- AA
- Chlorine
- HCN
- Sulfuric Acid
- HF
- Coffee

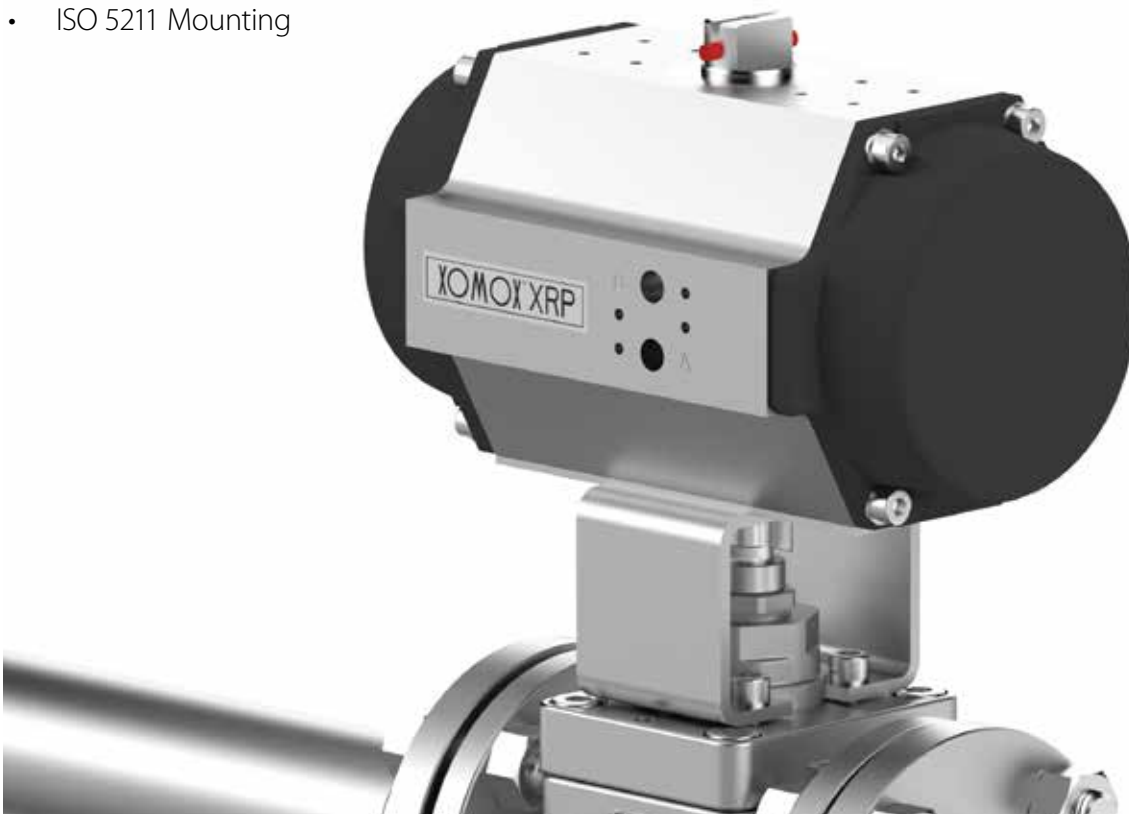

L-TORQ XOMOX

Brings remarkable benefits in torque, reparability and emissions performance, while maintaining the primary properties of a sleeved plug valve.

Features and Benefits

50%↓



TORQUE REDUCTION

**Conventional
Sleeved Plug Valve**

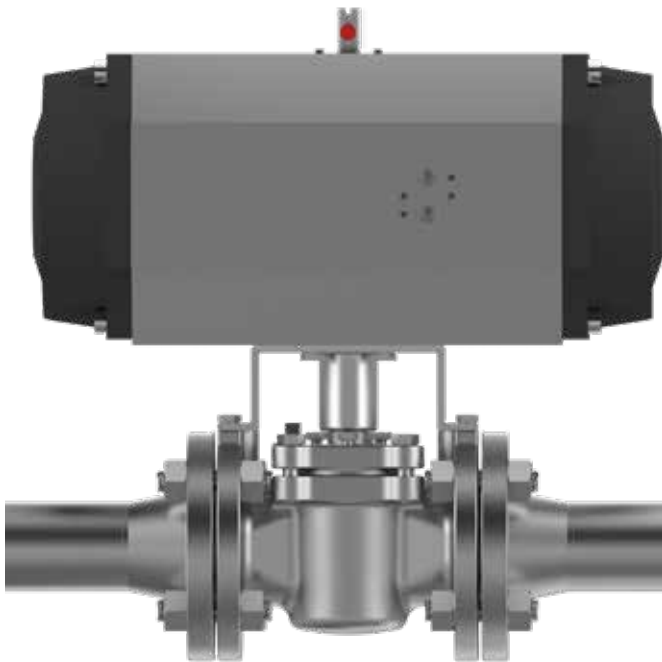

L-TORQ



Smaller Actuator

Lighter Weight
(Actuated Valves)

Longer Lifetime

Features and Benefits

SIMPLIFIED REPAIR



**Simplified
Repair**

**Compact Sleeve
cartridge design**

**Cover, Plug
and Sleeve Cartridge
Separate components**

Features and Benefits



FUGITIVE EMISSIONS



Meeting new
TA-LUFT 2021

ISO 15848-1
BH CO3 200°C
SSA0 Standard

Design Features

SLEEVE CARTRIDGE DESIGN

- Structure that supports the sleeve by giving more dimensional control.
- Fully encapsulated metal cage port lips in PFA – eliminating the crevice region that exist in conventional SPV design

INVERTED PLUG

- Provides effective control on sleeve compression
- Plug adjustment done by plug lifting
- Separated stem packing and plug adjustment

REPAIR KIT

- Compact sleeve cartridge design
- This simplified repair process does not require highly skilled personnel nor special tooling.



Properties and Characteristics

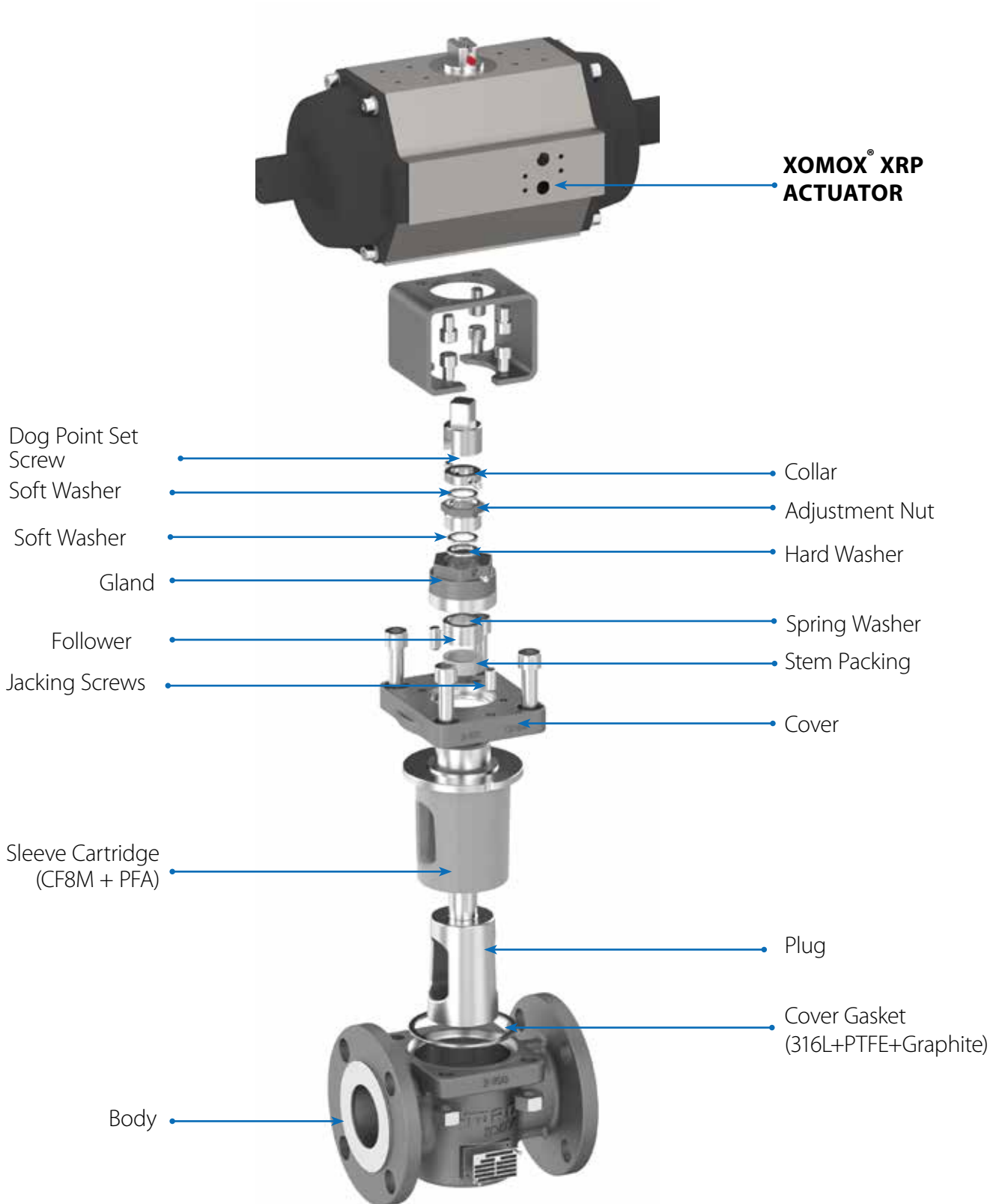

Design Features and Options



Available In
2-Way
Configuration
Class 150
and Class 300

Integrated
Locking Device
Available with
Lever And Gear
Operators

Actuator
Mounting
capabilities per
ISO 5211

Available in
Firesafe
Option as
per API 607

Pressure Temperature Ratings

PRESSURE-TEMPERATURE RATING

L-TORQ XOMOX FIG. L067 & L0367, SIZE 1/2"-6" 2-WAY, CLASS 150 & 300

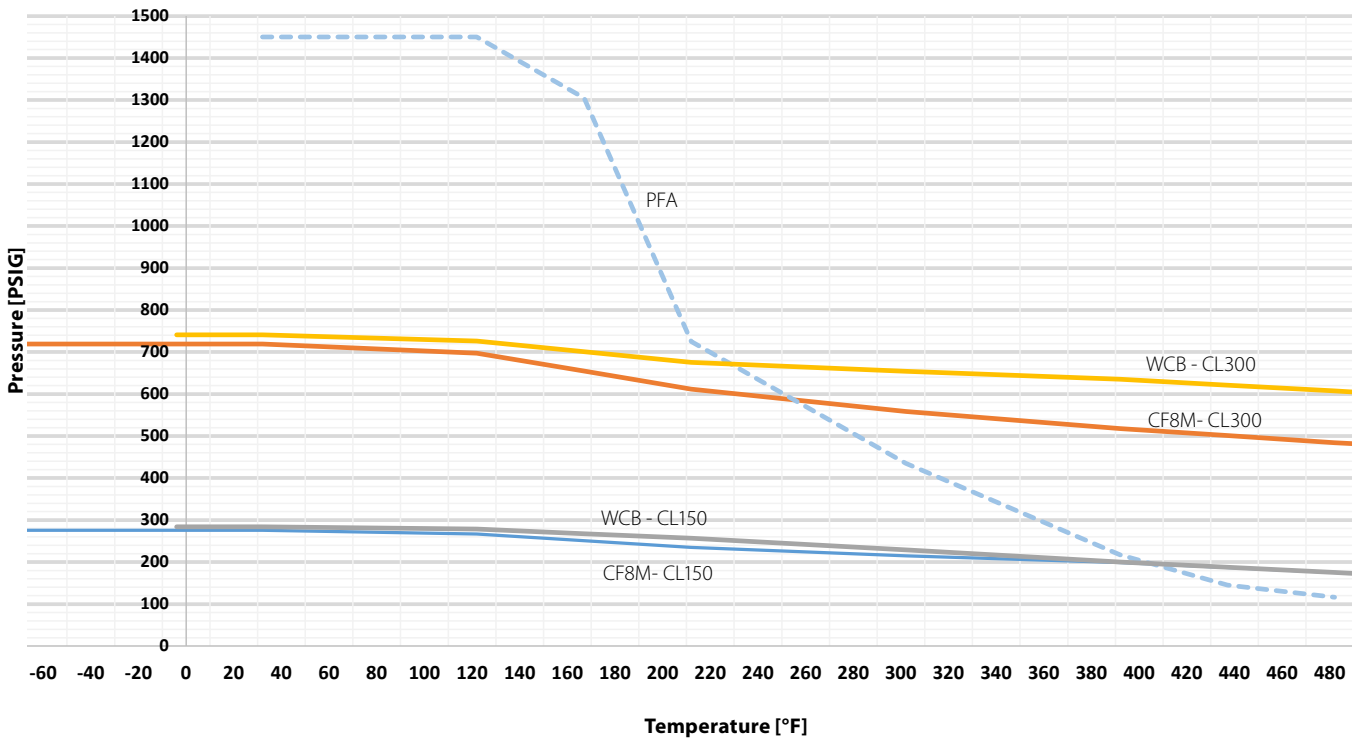

OPERATING TORQUES. (INCH-POUNDS)

Size	Break Torque	Seat Torque	Run Torque
1/2	100	80	70
3/4	100	80	70
1	190	150	130
1 1/2	400	320	280
2	545	435	380
3	660	530	460
4	1350	1080	950
6	2700	2165	1880

* Figures are for 2-Way valves with PFA Cartridge for clean media. For Chlorine, Oxygen etc. Dry Built configurations multiply the above values with 1.5

Dimensional Data

ACTUATED

L-TORQ XOMOX FIG. L067 & L0367, SIZE 1/2"-6", Class 150

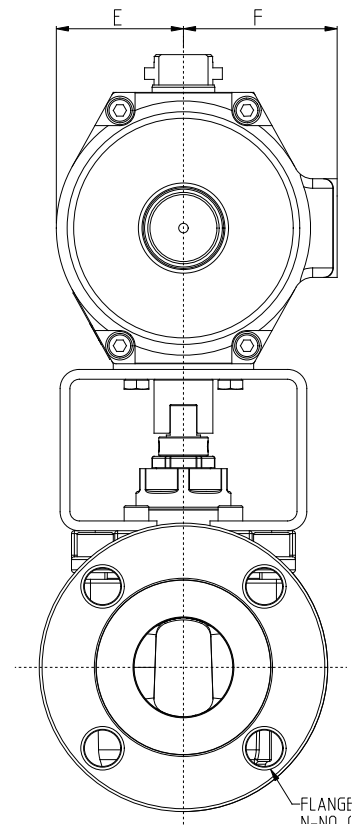
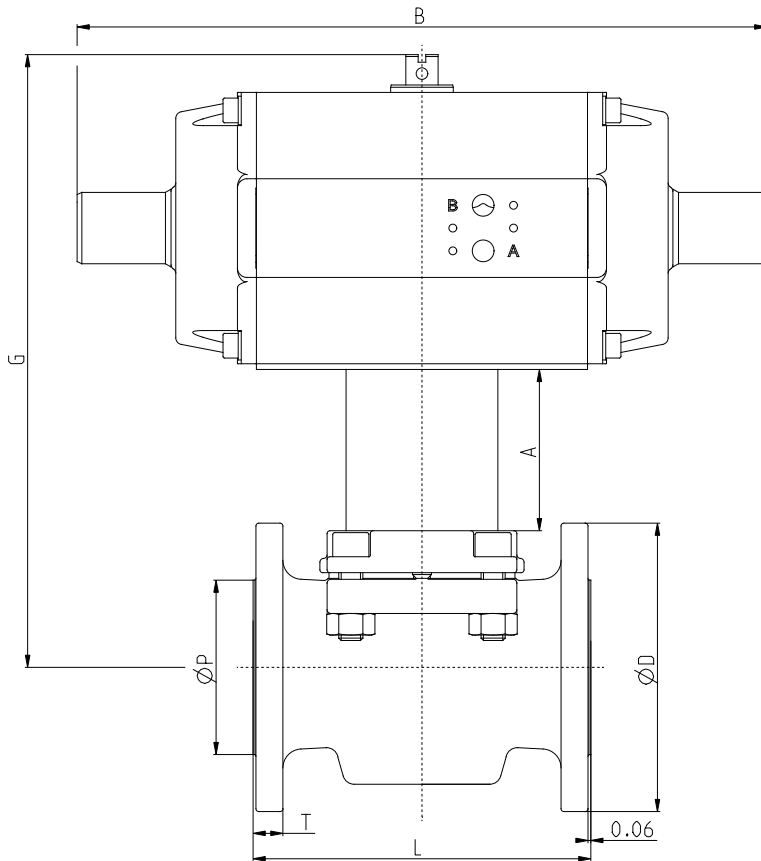

FLANGE BOLTING DETAILS
 N-NO OF BOLT HOLES
 O-DIA OF BOLT HOLES
 C-DIA OF BOLT CIRCLE
 CUST.

Single Acting with 80 PSIG air supply

L-TORQ XOMOX FIG. L067, SIZE 1/2"-6", Class 150

SIZE	CLASS	A	B	C	D	E	F	G	L	N	O	P	T	WEIGHT IN POUNDS	BARE STEM WEIGHT
1/2"	150	2.52	7.77	2.38	3.50	1.37	1.63	7.83	4.25	4.00	0.63	1.38	0.37	4.5	9.92
3/4"	150	2.52	7.77	2.75	3.90	1.37	1.63	7.83	4.61	4.00	0.63	1.69	0.40	4.9	10.8
1"	150	2.60	10.27	3.12	4.25	1.61	2.19	8.90	5.00	4.00	0.63	2.00	0.44	8	17.64
1 1/2"	150	3.35	11.34	3.88	5.00	2.17	2.72	11.34	6.50	4.00	0.63	2.87	0.56	12.5	27.56
2"	150	3.35	14.31	4.75	5.98	2.64	3.19	12.71	7.01	4.00	0.75	3.62	0.62	19.5	42.99
3"	150	3.35	14.31	6.00	7.48	2.64	3.19	13.26	7.99	4.00	0.75	5.00	0.75	26.7	58.86
4"	150	4.13	17.78	7.50	9.02	3.07	3.78	16.07	9.02	8.00	0.75	6.19	0.94	45.5	100.31
6"	150	4.33	20.83	9.50	10.98	3.54	4.02	18.63	10.51	8.00	0.88	8.50	1.00	77.2	170.2

Dimensional Data

Single Acting with 80 PSIG air supply

L-TORQ XOMOX FIG. L0367, SIZE 1/2"-6", Class 300

SIZE	CLASS	A	B	C	D	E	F	G	L	N	O	P	T	WEIGHT IN POUNDS	BARE STEM WEIGHT
1/2"	300	2.52	7.77	2.62	3.74	1.37	1.63	7.83	5.51	4.00	0.63	1.38	0.56	5.2	11.46
3/4"	300	2.52	7.77	3.25	4.61	1.37	1.63	7.83	5.98	4.00	0.75	1.69	0.62	6.1	13.45
1"	300	2.60	10.27	3.50	4.88	1.61	2.19	8.90	6.26	4.00	0.75	2.00	0.68	9.6	21.16
1 1/2"	300	3.35	11.34	4.50	6.10	2.17	2.72	11.34	7.48	4.00	0.88	2.87	0.81	15.7	34.61
2"	300	3.35	14.31	5.00	6.50	2.64	3.19	12.71	8.50	8.00	0.75	3.62	0.87	22.6	49.82
3"	300	3.35	14.31	6.62	8.27	2.64	3.19	13.26	11.10	8.00	0.88	5.00	1.12	33.9	74.74
4"	300	4.13	17.78	7.88	10.00	3.07	3.78	16.07	12.01	8.00	0.88	6.19	1.25	57.5	126.77
6"	300	4.33	20.83	10.62	12.52	3.54	4.02	18.63	15.87	8.00	0.88	8.50	1.44	103.4	227.96

Double Acting with 80 PSIG air supply

L-TORQ XOMOX FIG. L067 & L0367, SIZE 1/2"-6", Class 150 and 300

SIZE	CLASS	A	B	C	D	E	F	G	L	N	O	P	T	WEIGHT IN POUNDS	BARE STEM WEIGHT
1/2"	150	2.52	6.53	2.38	3.50	1.00	1.30	7.05	4.25	4.00	0.63	1.38	0.37	4	8.8
3/4"	150	2.52	6.53	2.75	3.90	1.00	1.30	7.05	4.61	4.00	0.63	1.69	0.40	4.4	9.7
1"	150	2.60	7.78	3.12	4.25	1.37	1.63	8.35	5.00	4.00	0.63	2.00	0.44	7.2	15.9
1 1/2"	150	3.35	10.27	3.88	5.00	1.61	2.19	10.16	6.50	4.00	0.63	2.87	0.56	11.8	26
2"	150	3.35	11.34	4.75	5.98	2.17	2.72	11.71	7.01	4.00	0.75	3.62	0.62	17.8	39.2
3"	150	3.35	11.34	6.00	7.48	2.17	2.72	12.26	7.99	4.00	0.75	5.00	0.75	25.5	56.2
4"	150	4.13	14.31	7.50	9.02	2.64	3.19	14.90	9.02	8.00	0.75	6.19	0.94	42.2	93
6"	150	4.33	17.78	9.50	10.98	3.07	3.78	17.59	10.51	8.00	0.88	8.50	1.00	72.8	160.5
1/2"	300	2.52	6.53	2.62	3.74	1.00	1.30	7.05	5.51	4.00	0.63	1.38	0.56	4.7	10.4
3/4"	300	2.52	6.53	3.25	4.61	1.00	1.30	7.05	5.98	4.00	0.75	1.69	0.62	5.8	12.8
1"	300	2.60	7.78	3.50	4.88	1.37	1.63	8.35	6.26	4.00	0.75	2.00	0.68	8.9	19.6
1 1/2"	300	3.35	10.27	4.50	6.10	1.61	2.19	10.16	7.48	4.00	0.88	2.87	0.81	15.3	33.7
2"	300	3.35	11.34	5.00	6.50	2.17	2.72	11.71	8.50	8.00	0.75	3.62	0.87	21.2	46.7
3"	300	3.35	11.34	6.62	8.27	2.17	2.72	12.26	11.10	8.00	0.88	5.00	1.12	33.3	73.4
4"	300	4.13	14.31	7.88	10.00	2.64	3.19	14.90	12.01	8.00	0.88	6.19	1.25	54.7	120.6
6"	300	4.33	17.78	10.62	12.52	3.07	3.78	17.59	15.87	8.00	0.88	8.50	1.44	100.8	222.2

ISO 15848 Standard Introduction



International
Organization for
Standardization

ISO 15848-1 is an International standard for fugitive emissions issued by the ISO Organization. It contains both dynamic life cycles and thermal cycles and is considered one of the most demanding fugitive emission standards for soft seated valves. This standard contains different levels of acceptance based on the number of thermal and mechanical cycles, temperature, and number of adjustments. The objective of ISO 15848-1 is to enable classification of performance in different designs and constructions of valves to reduce fugitive emissions.

INTERNATIONALISO
STANDARD 15848-1

Example Description Tables

ISO 15848 – 1 BH CO3 ^(200°C) 392°F – SSA0																								
<table border="1"> <thead> <tr> <th colspan="2">Part Composition</th> </tr> </thead> <tbody> <tr> <td> Part 1: Design <ul style="list-style-type: none"> System of classification and procedures of qualification for the tests of the valve type </td> <td> Part 2: Industrial (Production) <ul style="list-style-type: none"> Acceptance tests in production of the valves Non-destructive </td> </tr> </tbody> </table>		Part Composition		Part 1: Design <ul style="list-style-type: none"> System of classification and procedures of qualification for the tests of the valve type 	Part 2: Industrial (Production) <ul style="list-style-type: none"> Acceptance tests in production of the valves Non-destructive 	<table border="1"> <thead> <tr> <th colspan="2">Number of Adjustments</th> </tr> </thead> <tbody> <tr> <td colspan="2" style="text-align: center;">0 / 1 / 2 / 3</td> </tr> </tbody> </table>			Number of Adjustments		0 / 1 / 2 / 3													
Part Composition																								
Part 1: Design <ul style="list-style-type: none"> System of classification and procedures of qualification for the tests of the valve type 	Part 2: Industrial (Production) <ul style="list-style-type: none"> Acceptance tests in production of the valves Non-destructive 																							
Number of Adjustments																								
0 / 1 / 2 / 3																								
		<table border="1"> <thead> <tr> <th colspan="5">Temperature Classes</th> </tr> <tr> <th>(T-196 °C)</th> <th>(T-40 °C)</th> <th>(T RT)</th> <th>(T200 °C)</th> <th>(T400 °C)</th> </tr> </thead> <tbody> <tr> <td>-320°F</td> <td>-40°F</td> <td>Room temperature, °F</td> <td>392°F</td> <td>752°F</td> </tr> <tr> <td>-196°C</td> <td>-40°C</td> <td>Room temperature, °C</td> <td>200°C</td> <td>400°C</td> </tr> </tbody> </table>			Temperature Classes					(T-196 °C)	(T-40 °C)	(T RT)	(T200 °C)	(T400 °C)	-320°F	-40°F	Room temperature, °F	392°F	752°F	-196°C	-40°C	Room temperature, °C	200°C	400°C
Temperature Classes																								
(T-196 °C)	(T-40 °C)	(T RT)	(T200 °C)	(T400 °C)																				
-320°F	-40°F	Room temperature, °F	392°F	752°F																				
-196°C	-40°C	Room temperature, °C	200°C	400°C																				
<table border="1"> <thead> <tr> <th>Class</th> <th>Measured Leak Rate^a mg s⁻¹ m⁻¹</th> <th>Remarks</th> </tr> </thead> <tbody> <tr> <td>A^b</td> <td>≤ 10⁻⁶</td> <td>Typically achieved with bellow seals or and equivalent stem (shaft) sealing system for quarter turn valves</td> </tr> <tr> <td>B</td> <td>≤ 10⁻⁴</td> <td>Typically achieved with PTFE based packings or elastomeric seals</td> </tr> <tr> <td>C</td> <td>≤ 10⁻²</td> <td>Typically achieved with flexible graphite based packings</td> </tr> </tbody> </table>		Class	Measured Leak Rate ^a mg s ⁻¹ m ⁻¹	Remarks	A ^b	≤ 10 ⁻⁶	Typically achieved with bellow seals or and equivalent stem (shaft) sealing system for quarter turn valves	B	≤ 10 ⁻⁴	Typically achieved with PTFE based packings or elastomeric seals	C	≤ 10 ⁻²	Typically achieved with flexible graphite based packings	<table border="1"> <thead> <tr> <th>Classification</th> <th>Minimum number of mechanical cycles</th> </tr> </thead> <tbody> <tr> <td>CO1</td> <td>500 cycles, with two thermal cycles (except for RT)</td> </tr> <tr> <td>CO2</td> <td>1,500 cycles, with three thermal cycles</td> </tr> <tr> <td>CO3</td> <td>2,500 cycles, with four thermal cycles</td> </tr> </tbody> </table>			Classification	Minimum number of mechanical cycles	CO1	500 cycles, with two thermal cycles (except for RT)	CO2	1,500 cycles, with three thermal cycles	CO3	2,500 cycles, with four thermal cycles
Class	Measured Leak Rate ^a mg s ⁻¹ m ⁻¹	Remarks																						
A ^b	≤ 10 ⁻⁶	Typically achieved with bellow seals or and equivalent stem (shaft) sealing system for quarter turn valves																						
B	≤ 10 ⁻⁴	Typically achieved with PTFE based packings or elastomeric seals																						
C	≤ 10 ⁻²	Typically achieved with flexible graphite based packings																						
Classification	Minimum number of mechanical cycles																							
CO1	500 cycles, with two thermal cycles (except for RT)																							
CO2	1,500 cycles, with three thermal cycles																							
CO3	2,500 cycles, with four thermal cycles																							
<p>^a Expressed in mg s⁻¹ m⁻¹ measured with total leakage method ^b Class A can be measured only with helium using the vacuum method</p>		<table border="1"> <thead> <tr> <th>Test Fluid</th> <th>Class</th> </tr> </thead> <tbody> <tr> <td>H - Helium</td> <td>AH, BH, CH</td> </tr> <tr> <td>M - Methane</td> <td>BM, CM</td> </tr> </tbody> </table> <p>When the test fluid is helium, classes are identified as AH, BH and CH. When the test fluid is methane, classes are identified as BM and CM.</p>			Test Fluid	Class	H - Helium	AH, BH, CH	M - Methane	BM, CM														
Test Fluid	Class																							
H - Helium	AH, BH, CH																							
M - Methane	BM, CM																							

Manufacturing valves will be subjected to the ISO 15848-2 test as described in the norm. This is a non-destructive test that intends to address the performance of the valves (Please refer to ISO 15848 norm).

How to Order

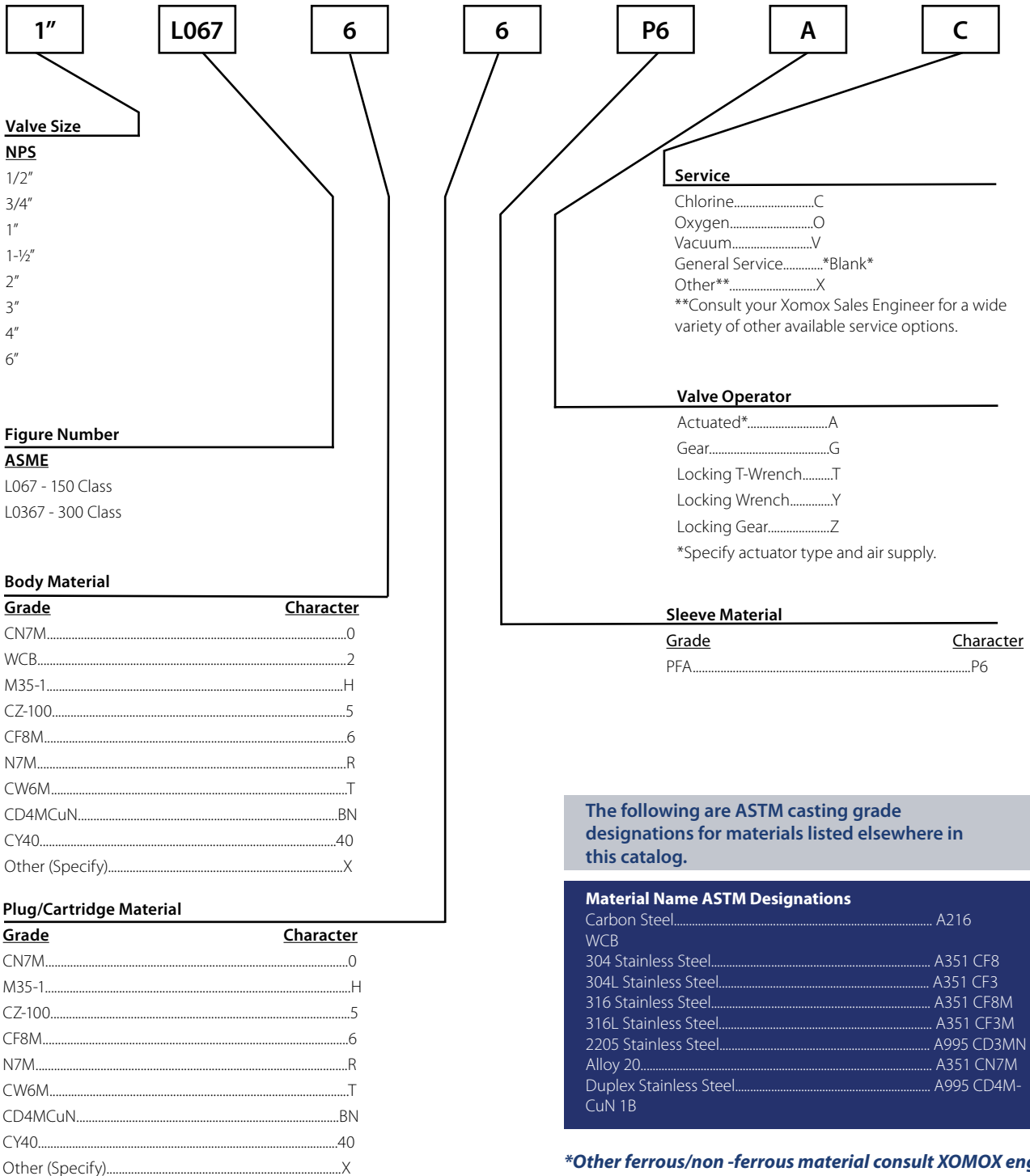

The following are ASTM casting grade designations for materials listed elsewhere in this catalog.

Material Name ASTM Designations

Carbon Steel.....	A216
WCB	
304 Stainless Steel.....	A351 CF8
304L Stainless Steel.....	A351 CF3
316 Stainless Steel.....	A351 CF8M
316L Stainless Steel.....	A351 CF3M
2205 Stainless Steel.....	A995 CD3MN
Alloy 20.....	A351 CN7M
Duplex Stainless Steel.....	A995 CD4M-CuN 1B

***Other ferrous/non-ferrous material consult XOMOX engineer**

CRANE®

CRANE CHEMPHARMA & ENERGY

XOMOX® Headquarters
4444 Cooper Rd.
Cincinnati, OH 45242, USA
Tel: +1 513 745 6000
Fax: +1 513 745 6086

Xomox International GmbH & Co. OHG
Von-Behring-Straße 15
8131 Lindau/Bodensee, Germany
Tel: +49 8382 702 0
Fax: +49 8382 702 144

Crane Co., and its subsidiaries cannot accept responsibility for possible errors in catalogues, brochures, other printed materials, and website information. Crane Co. reserves the right to alter its products without notice, including products already on order provided that such alteration can be made without changes being necessary in specifications already agreed. All trademarks in this material are the property of the Crane Co. or its subsidiaries. The Crane and Crane brands logotype (CENTER LINE®, COMPAC-NOZ®, CRANE®, DEPA® & ELRO®, DOPAK®, DUO-CHEK®, FLOWSEAL®, GYROLOK®, GO REGULATOR®, HOKE®, JENKINS®, KROMBACH®, NOZ-CHEK®, PACIFIC VALVES®, RESISTOFLEX®, REVO®, SAUNDERS®, STOCKHAM®, TEXAS SAMPLING®, TRIANGLE®, UNI-CHEK®, VALVES®, WESTLOCK CONTROLS®, WTA®, and XOMOX®) are registered trademarks of Crane Co. All rights reserved.