

brands you trust.



Saunders[®] IDV Diaphragms
eXtreme Elastomer Range
High Performance PTFE Range

OVERVIEW AND PERFORMANCE

Saunders® eXtreme Elastomer Range

Code	ISO	Type	Sizes	Temperature	Typical Applications
XB	IIR	A & KB Type	DN8 - DN350	-40°C to 130°C	Titanium Dioxide Potable Water Brine
XE	EPDM	A & KB Type	DN8 - DN350	-40°C to 130°C	Phosphatic Fertilizers Water Treatment Potable Water
XC	FKM	A & KB Type	DN8 - DN350	-5°C to 150°C	High Temperature Acids Sulphuric Acid Hydrochloric Acid
XF	CSM	A Type	DN65	-10°C to 100°C	Fire mains isolation

Saunders® High Performance PTFE Range

Code	ISO	Type	Sizes	Temperature	Typical Applications
PB	PTFE/IIR	A Type	DN8 - DN250	-20°C to 150°C	Concentrated Hydrochloric Acid Caustic Soda
PE	PTFE/EPDM	A Type	DN8 - DN250	-20°C to 150°C	Nitric Acid Concentrated Acids and Alkalis
PC	PTFE/FKM	A Type	DN8 - DN250	-5°C to 175°C	Sulphuric Acid, Strong Acids at high Temperature
KE	PTFE/PVDF/EPDM	A Type	DN15 - DN100, DN150	-20°C to 100°C	Chlorinated Solvents Bromine Services
KC	PTFE/PVDF/FKM	A Type	DN15 - DN100, DN150	-20°C to 130°C	Aggressive Chlorine Services

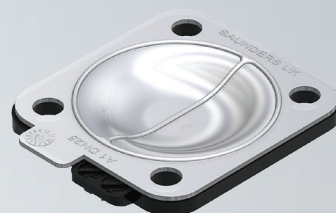
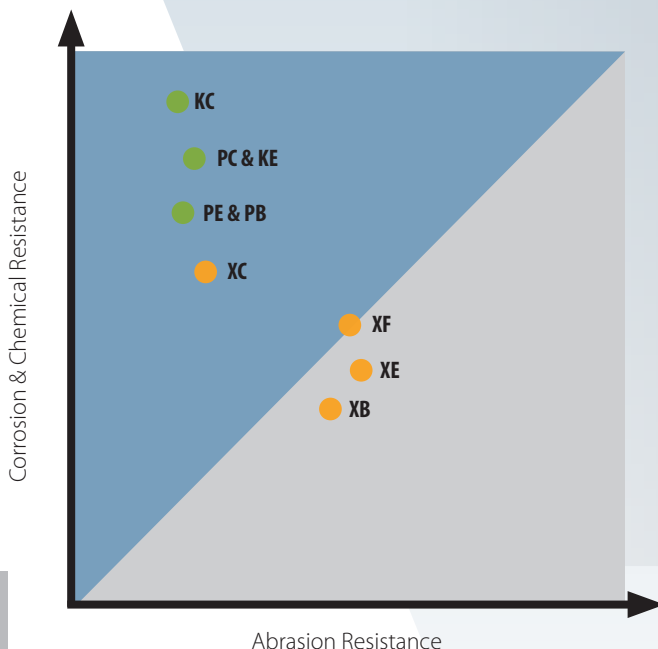

SAUNDERS EXTREME ELASTOMER RANGE

The Saunders® diaphragm is an intricate design and not a simple moulded part. Layers of proprietary blended and calendared (rolled into sheet form) rubber is vulcanized with high strength woven reinforcement.

Key Features

- 1 Diaphragms constructed with multiple layers of rubber and fabric reinforcement for **optimised flex performance**, even in high-cycle applications.
- 2 Sealing ribs on the diaphragms wetted face provide **enhanced leak-tight sealing capabilities and lower closure torques**.
- 3 Proprietary formulations, solely manufactured in-house, deliver the necessary physical properties to provide **excellent abrasion and corrosion resistance**.

Polymer expertise since 1934

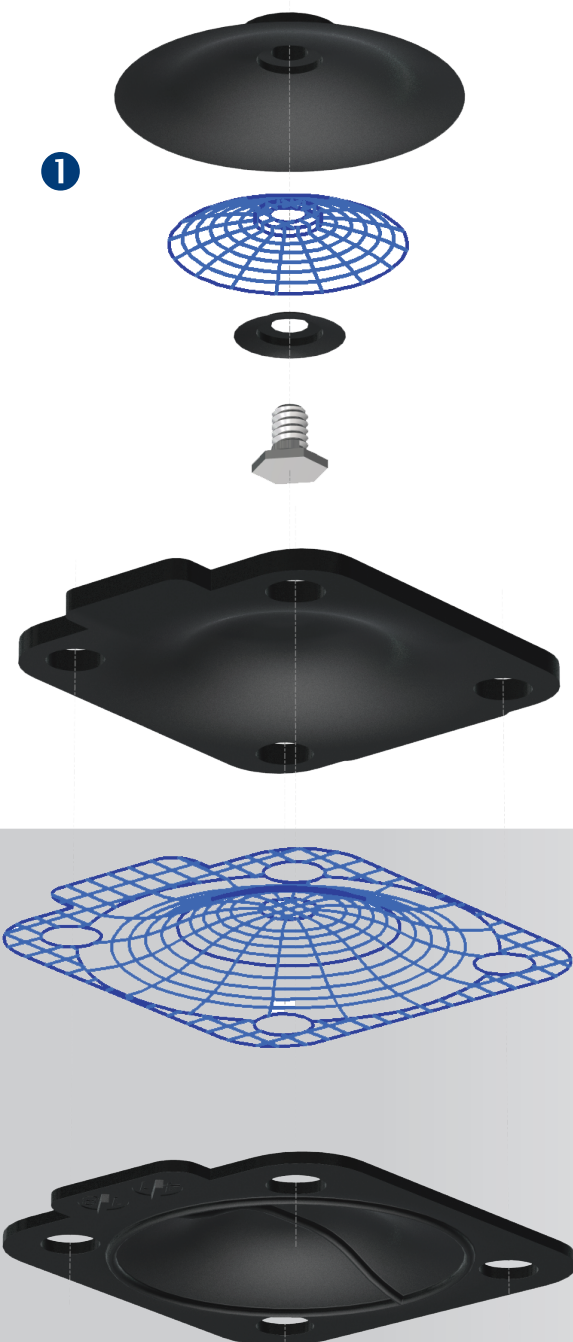

XE GRADE DIAPHRAGM

Saunders® XE grade diaphragms are best used for both abrasive and corrosive applications such as phosphoric acid, metal treatment and mining applications, as well as salts in water, acids and alkalis, ozone, potable drinking water and intermittent steam.

Size	Grade	Catalogue Code
DN8-DN350	XE	XE



Customer Benefits

- Up to 40% improvement in compression set characteristic
- Reducing the need for re-torquing and ensuring seal to atmosphere
- 100% compatible with all existing installations of Saunders industrial product ranges
- A coding tag for traceability of both materials and manufacturing data

Construction

- Ethylene propylene diene (EPDM)
- Organic peroxide cured
- Carbon black reinforced
- Fabric reinforced to optimize flex

Size Range

- DN008 – DN350 / 0.25" - 14"

Compliance and Traceability

- Fully lot traceable to BS EN 10204 3.1b (On request)

Temperature Range

- Type A: -40°C to 130°C / -40°F to 266°F
- Type KB: -40°C to 100°C / -40°F to 212°F

Typical Applications

- Chlor Alkali, Demineralisers, Filtrations, HVAC, Waste Streams

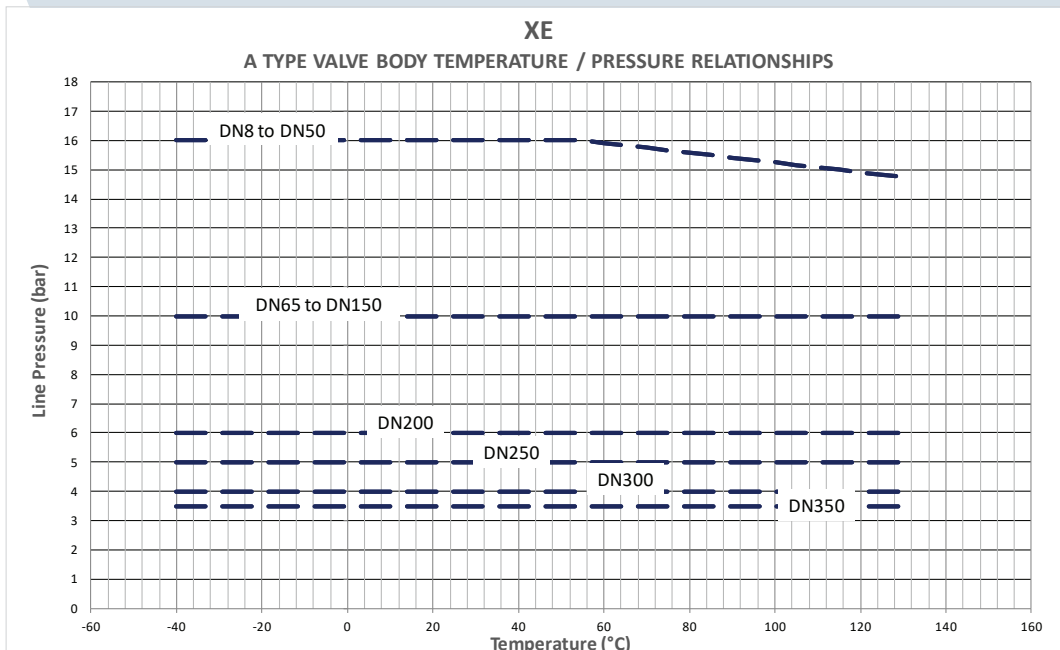

XB GRADE DIAPHRAGM

Saunders® XB offers the best-in-class solution in water applications due to its low moisture permeability, as well as excellent resistance to heat, aging and weathering. It also offers great performance for diluted acids and alkalis, and additional abrasive applications like phosphoric acid in low concentrations.

Size	Grade	Catalogue Code
DN8-DN350	XB	XB



Customer Benefits

- Highest tensile strength properties of all elastomer grade diaphragms
- Provides strength in the toughest of applications
- 100% compatible with all existing installations of Saunders industrial product ranges
- A coding tag for traceability of both materials and manufacturing data

Construction

- Isobutylene Isoprene (IIR)
- Resin cured
- Carbon black reinforced
- Fabric reinforced to optimize flex

Size Range

- DN008 – DN350 / 0.25" - 14"

Compliance and Traceability

- Fully lot traceable to BS EN 10204 3.1b (On request)
- WRAS approved

Temperature Range

- Type A: -40°C to 130°C / -40°F to 266°F
- Type KB: -40°C to 100°C / -40°F to 212°F

Typical Applications

- Demineralisers, Filtrations, HVAC, Potable Water, Utility Services

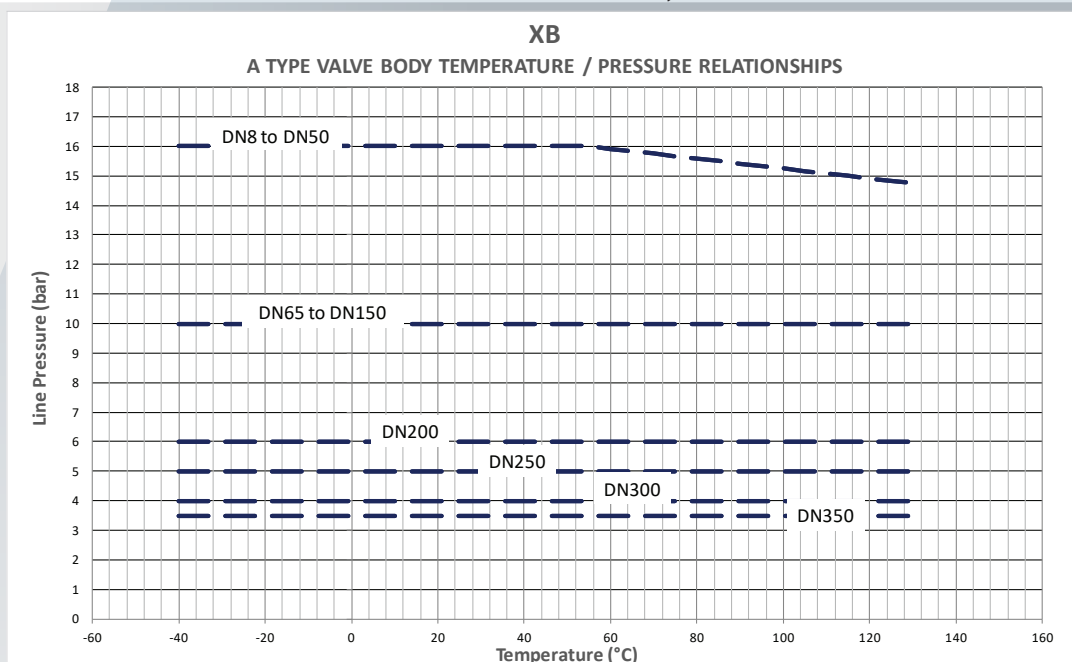

XC GRADE DIAPHRAGM

Saunders® XC offers strong resistance to aromatic hydrocarbons and high temperature concentrated acids. It is also a great solution for hydrogen at high temperatures, low concentrated chlorine solutions, ozone, sulphuric acid and unleaded petroleum.

Size	Grade	Catalogue Code
DN8-DN350	XC	XC



Customer Benefits

- Highest permeation resistance properties of all elastomer grades
- Perfect choice for high temperature chemical applications
- 100% compatible with all existing installations of Saunders industrial product ranges
- A coding tag for traceability of both materials and manufacturing data

Construction

- Fluoroelastomer (FKM)
- Amine cured
- Carbon black reinforced
- Fabric reinforced to optimize flex

Size Range

- DN015 – DN350 / 0.5" - 14"

Compliance and Traceability

- Fully lot traceable to BS EN 10204 3.1b (On request)

Temperature Range

- Type A: -5°C to 150°C / 23°F to 302°F
- Type KB: +5°C to 120°C / 41°F to 248°F

Typical Applications

- Chlor Alkali, Chemical, Demineralisers, Phosphate Fertilizers

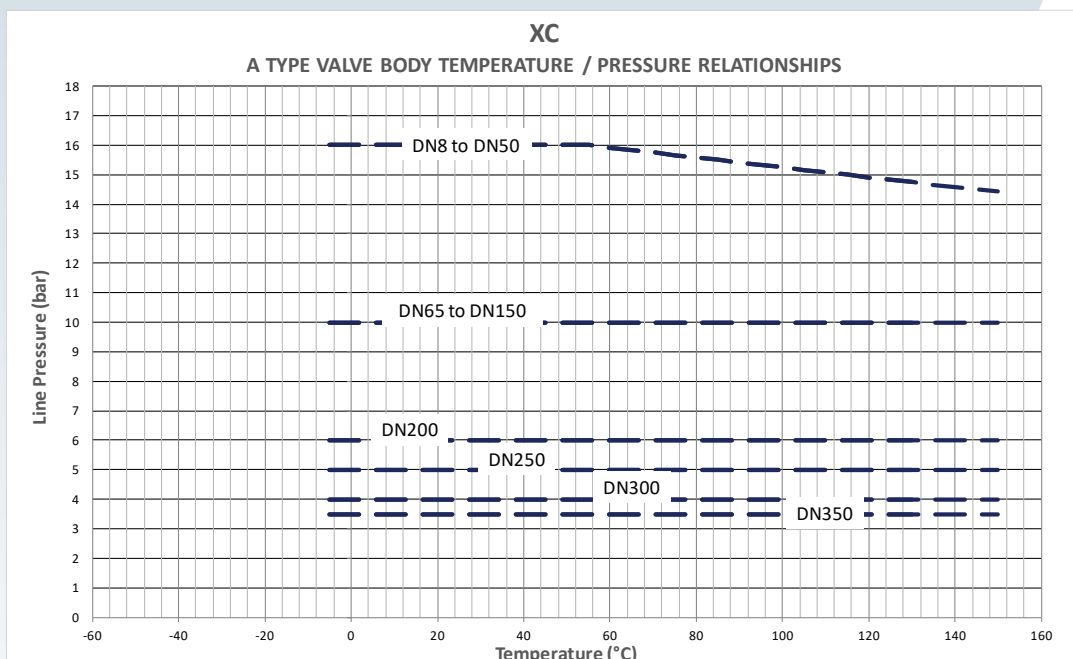

XF GRADE DIAPHRAGM

Saunders® XF is designed to have fire resistant properties with a higher specification fabric making it the perfect solution for fire hydrant applications when used in conjunction with Saunders WFB valves.

Size	Grade	Catalogue Code
DN65	XF	XF



Customer Benefits

- This grade of diaphragm has undergone stringent high temperature resistance tests
- 100% compatible with all existing installations of Saunders industrial product ranges
- A coding tag for traceability of both materials and manufacturing data

Construction

- Chlorosulphonated Polyethylene (CSM Fire)
- Metal oxide cured
- Carbon black reinforced
- Kevlar fabric reinforced

Size Range

- DN65 / 2.5"

Compliance and Traceability

- Fully lot traceable to BS EN 10204 3.1b (On request)

Temperature Range

- Type A: -10°C to 100°C / 14°F to 212°F

Typical Applications

- Cruise liners, on & off shore refineries, naval vessels and high rise buildings

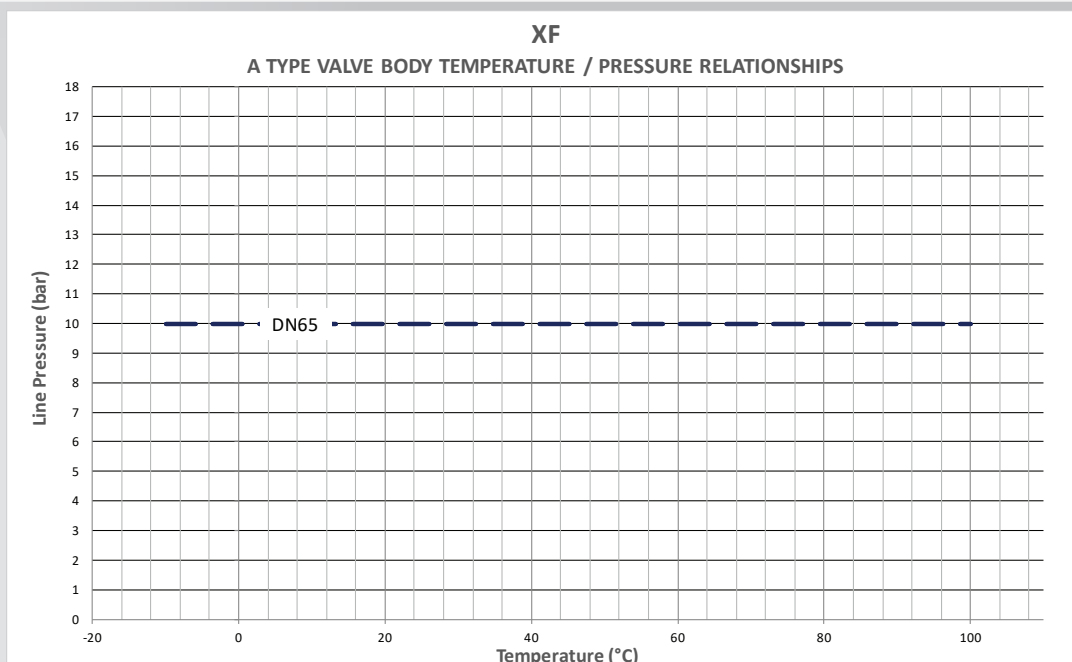

SAUNDERS HIGH PERFORMANCE PTFE RANGE

Saunders® High Performance PTFE diaphragms are a robust two-piece or three-piece design utilising a wetted PTFE face backed with a fabric reinforced elastomer layer. Saunders® maintains front-to-back ownership of all phases of diaphragm development and manufacture, including sintering and coining of PTFE diaphragm faces.

Key Features

- ① Unique stainless steel bayonet fitment, reduces point loading, **improves sealing performance** and facilitates correct diaphragm installation
- ② Third generation two-piece construction **increases pressure rating and enhances durability**, extending diaphragm lifetime
- ③ 100% virgin PTFE contact face is chemically inert, offering **enhanced corrosion resistance and extending diaphragm lifetime** in the most aggressive of services

*Polymer expertise
since 1934*

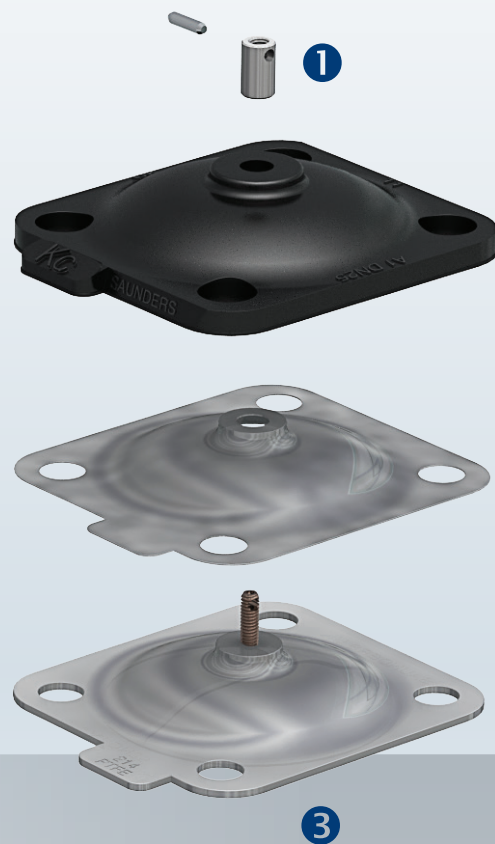

PE GRADE DIAPHRAGM

Saunders® PE typical applications include strong acids and alkalis, salts in water at high temperatures. This diaphragm works well with constant / intermittent steam and can also be used for high purity processes where cleanability is essential.

Size	Grade	Catalogue Code
DN8-DN250	PE	PE



Customer Benefits

- 100% compatible with all existing installations of Saunders industrial product ranges
- A coding tag for traceability of both materials and manufacturing data
- 100% virgin PTFE contact face is chemically inert, offering enhanced corrosion resistance and extending diaphragm lifetime in the most aggressive of services

Construction

- 100% virgin PTFE Face
- Ethylene propylene diene (EPDM) backing

Size Range

- DN015 – DN250 / 0.5" - 10"

Compliance and Traceability

- Fully lot traceable to BS EN 10204 3.1b (On request)

Temperature Range

- Type A: -20°C to 150°C / -4°F to 302°F

Typical Applications

- Chlor-alkali, phosphatic Fertilizers, nitric acid, food and beverage

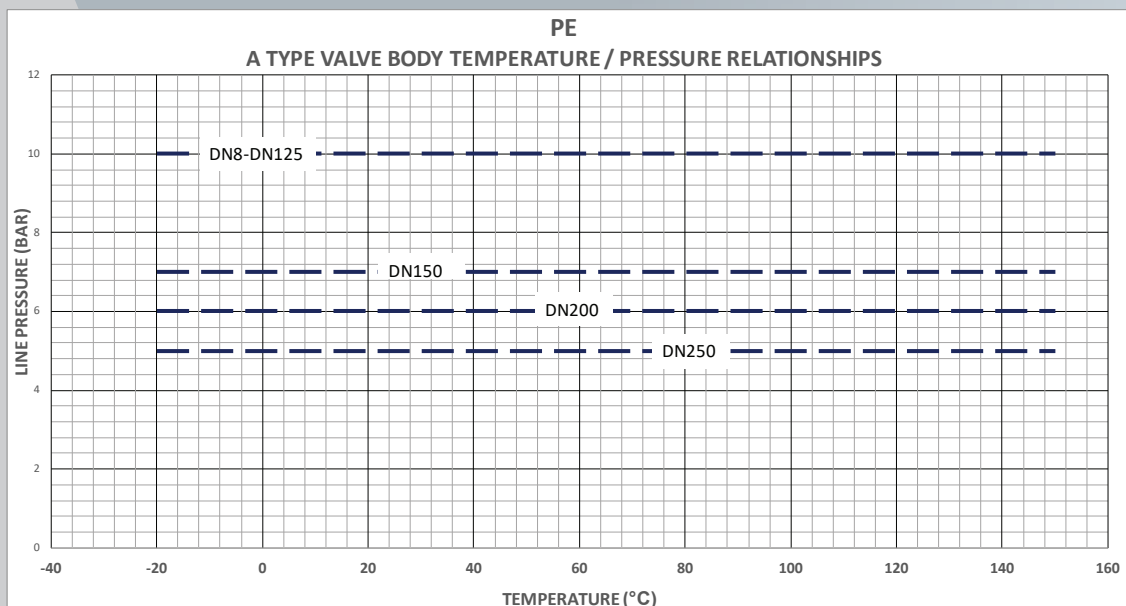

PB GRADE DIAPHRAGM

Saunders® PB offers the best-in-class solution for strong acids and alkalis such as concentrated hydrochloric acid and high temperature sulphuric acid. PB can also be used in the food and beverage industry where a contamination-free product is required.

Size	Grade	Catalogue Code
DN8-DN250	PB	PB



Customer Benefits

- 100% compatible with all existing installations of Saunders industrial product ranges
- A coding tag for traceability of both materials and manufacturing data
- 100% virgin PTFE contact face is chemically inert, offering enhanced corrosion resistance and extending diaphragm lifetime in the most aggressive of services

Construction

- 100% virgin PTFE face
- Isobutylene Isoprene (IIR) backing

Size Range

- DN008 – DN250 / 0.25" - 10"

Compliance and Traceability

- Fully lot traceable to BS EN 10204 3.1b (On request)

Temperature Range

- Type A: -20°C to 150°C / -4°F to 302°F

Typical Applications

- Chlor-alkali, phosphatic fertilizers, hydrochloric acid, food and beverage

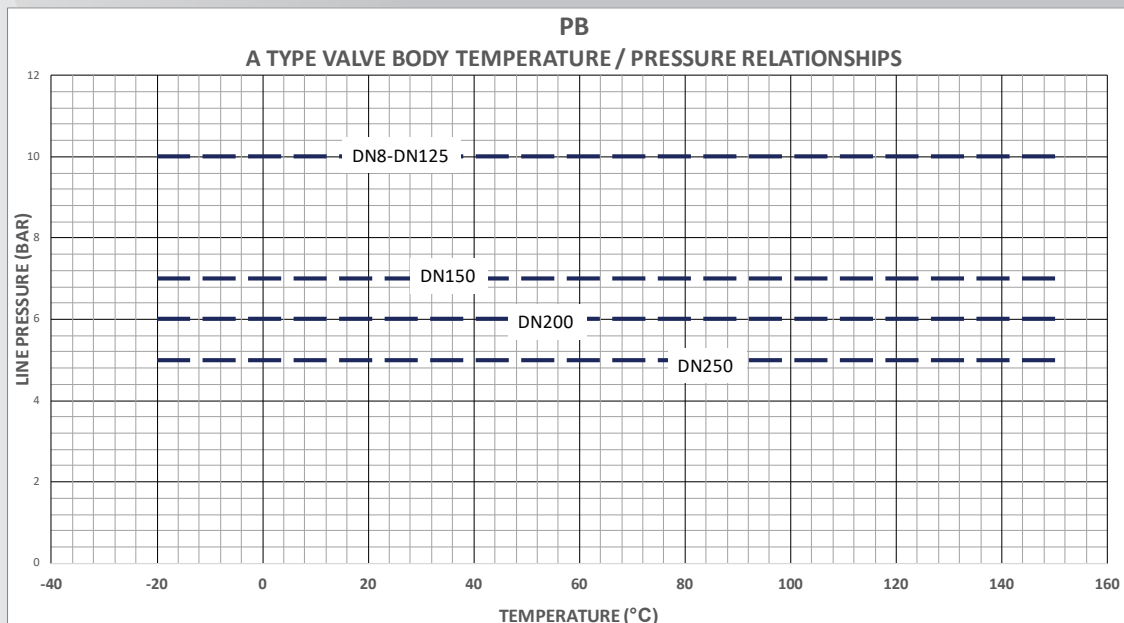

PC GRADE DIAPHRAGM

Saunders® PC is designed for strong acids at high temperatures and critical applications such as aggressive sulphuric acid, diluted chlorine and bromine solutions at low concentration.

Size	Grade	Catalogue Code
DN8-DN250	PC	PC

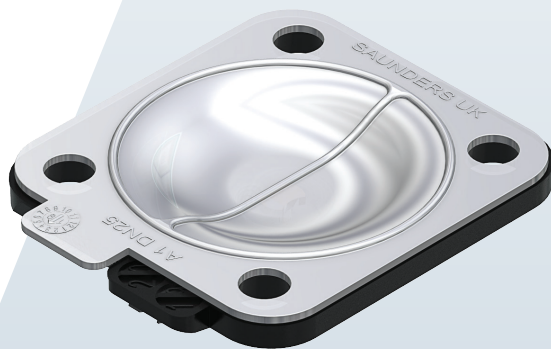

Customer Benefits

- Improved permeation resistance due to FKM backing offering longer life for critical applications
- 100% compatible with all existing installations of Saunders industrial product ranges
- A coding tag for traceability of both materials and manufacturing data
- 100% virgin PTFE contact face is chemically inert, offering enhanced corrosion resistance and extending diaphragm lifetime in the most aggressive of services

Construction

- 100% virgin PTFE Face
- Fluoroelastomer Compound (FKM) backing

Size Range

- DN008 – DN250 / 0.25" - 10"

Compliance and Traceability

- Fully lot traceable to BS EN 10204 3.1b (On request)

Temperature Range

- Type A: -5°C to 175°C / 23°F to 347°F

Typical Applications

- Chemical applications, sulphuric acid and bromine services

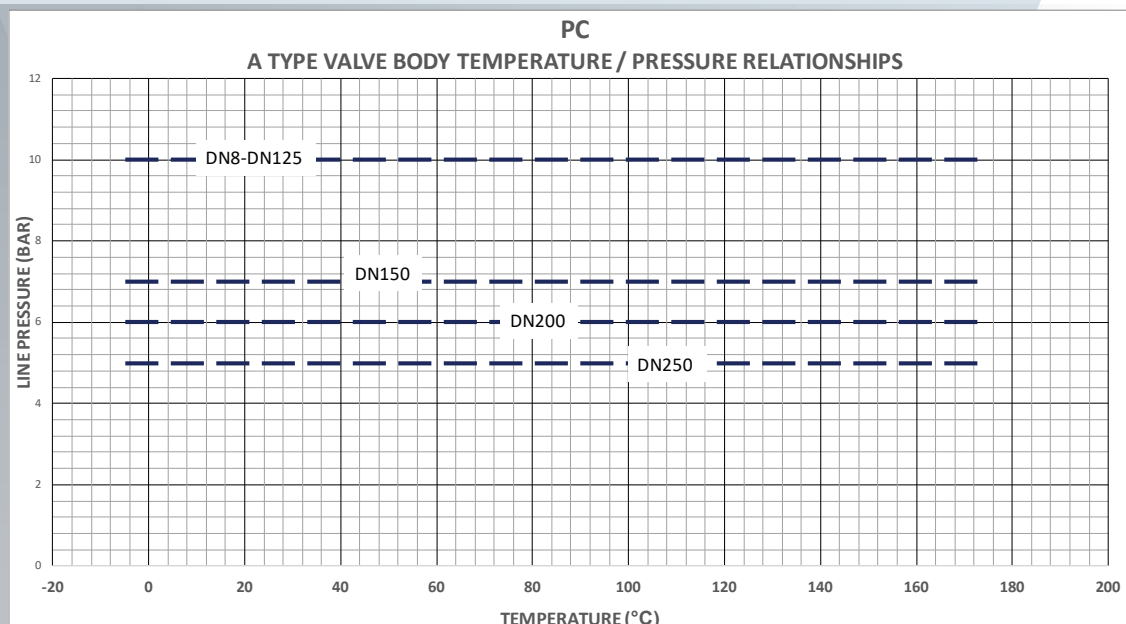

KE GRADE DIAPHRAGM

Saunders® KE is typically used for demanding applications where permeation resistance is a priority for services such as chlorine, bromine and chlorinated solutions.

Size	Grade	Catalogue Code
DN8-DN100, DN150	KE	KE

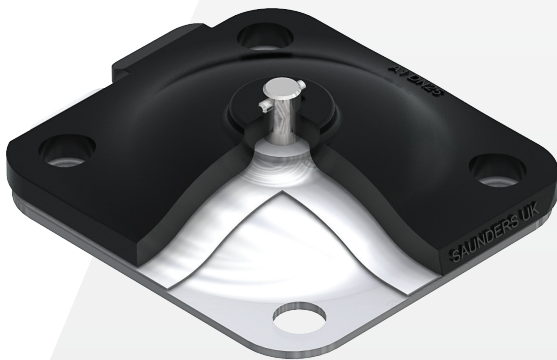

Customer Benefits

- PVDF interlayer offers enhanced permeation resistance reducing the total cost of ownership for critical applications
- 100% compatible with all existing installations of Saunders industrial product ranges
- A coding tag for traceability of both materials and manufacturing data
- 100% virgin PTFE contact face is chemically inert, offering enhanced corrosion resistance and extending diaphragm lifetime in the most aggressive of services

Construction

- 100% virgin PTFE
- PVDF interlayer
- Ethylene propylene diene (EDPDM) backing

Size Range

- DN15-DN100, DN150 / 0.5"-4",6"

Compliance and Traceability

- Fully lot traceable to BS EN 10204 3.1b (On request)

Temperature Range

- Type A: -20°C to 100°C / -4°F to 266°F

Typical Applications

- Bromine services and chlorinated solutions

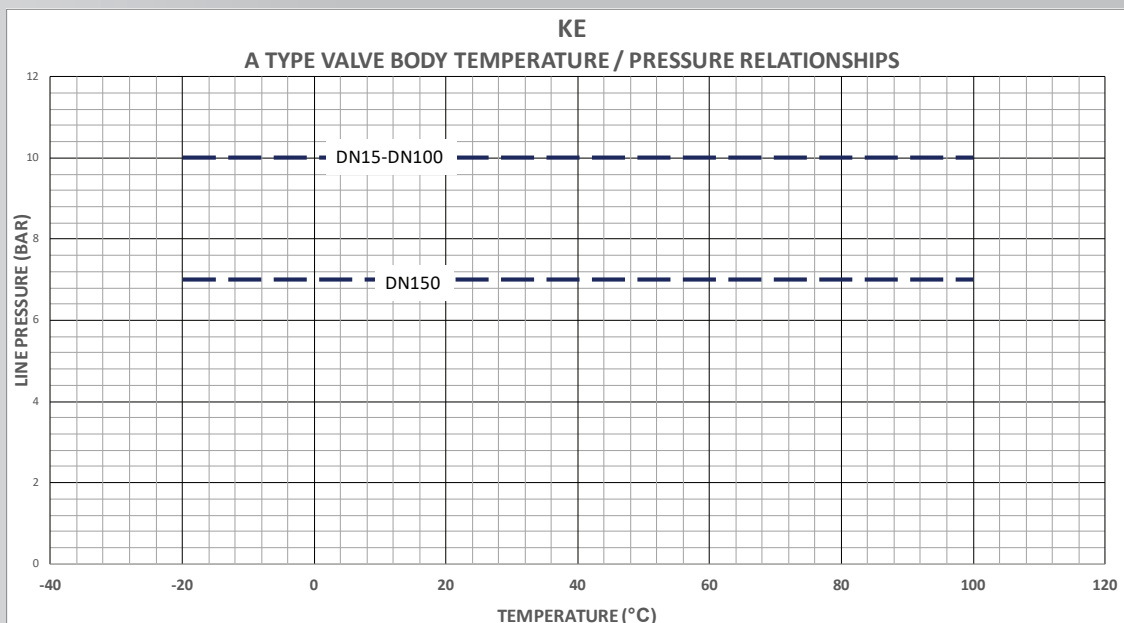

KC GRADE DIAPHRAGM

Saunders® KC Chlorine diaphragm is complete with PVDF interlayer, fluoroelastomer backing and titanium stud. This industry leading combination ensures the longest in-service diaphragm lifetime for aggressive chlorine applications.

Size	Grade	Catalogue Code
DN8-DN100, DN150	KC	KC



Customer Benefits

- Best permeation and corrosion-resistant diaphragm for aggressive chlorine applications
- Titanium stud enables high corrosion resistance
- 100% compatible with all existing installations of Saunders industrial product ranges
- A coding tag for traceability of both materials and manufacturing data
- 100% virgin PTFE contact face is chemically inert, offering the best corrosion resistance and extending diaphragm lifetime in the most aggressive of services

Construction

- 100% virgin PTFE face
- PVDF interlayer
- Fluoroelastomer (FKM) backing
- Titanium stud

Size Range

- DN15-DN100, DN150 / 0.5"-4",6"

Compliance and Traceability

- Fully lot traceable to BS EN 10204 3.1b (On request)

Temperature Range

- Type A: -20°C to 130°C / -4°F to 266°F

Typical Applications

- Aggressive chlorine applications

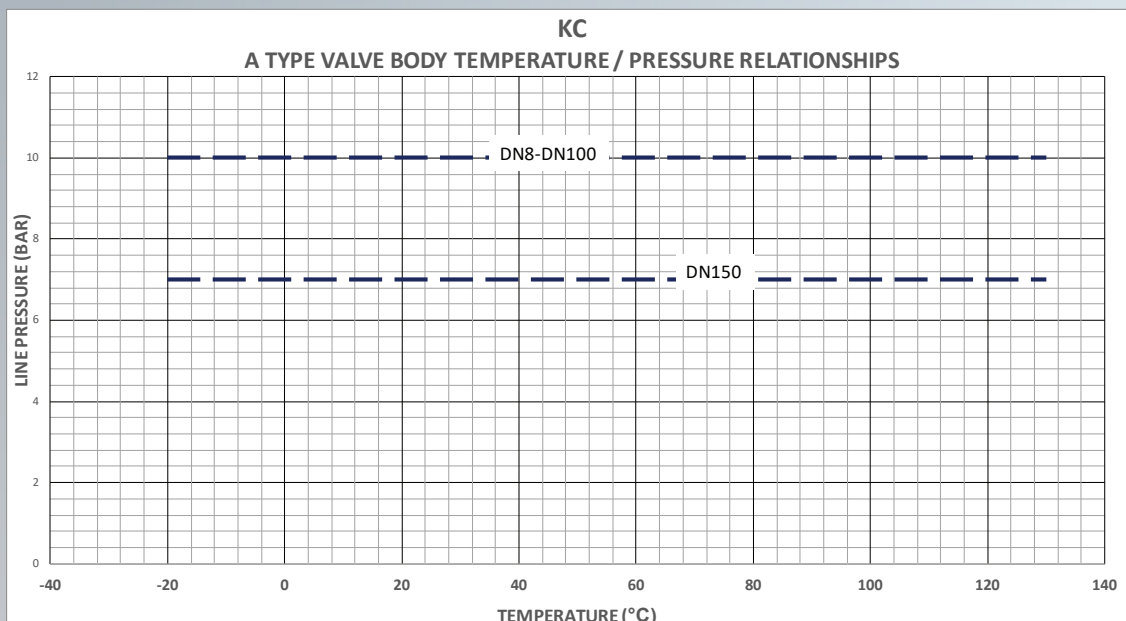

FREQUENTLY ASKED QUESTIONS

Do you still offer other grades of Saunders® diaphragms?

Yes, we can offer other Saunders diaphragm grades such as natural rubber, nitrile rubber and polychloroprenes etc. on request.

How should I install my Saunders® diaphragm?

There are a number of steps to consider for successful Saunders® diaphragm replacement/installation. For full instructions please refer to our installation and operating manual. However the key points to note are:

1. Compressor engagement – depending on the diaphragm fitment type (i.e. button, screw or bayonet)
2. Centralization procedure – gradual tightening of the bonnet bolts in the correct pattern to achieve even loading
3. Bolting Torques – application (and reapplication after 24 hours or one heat cycle) of the correct final bolting torques

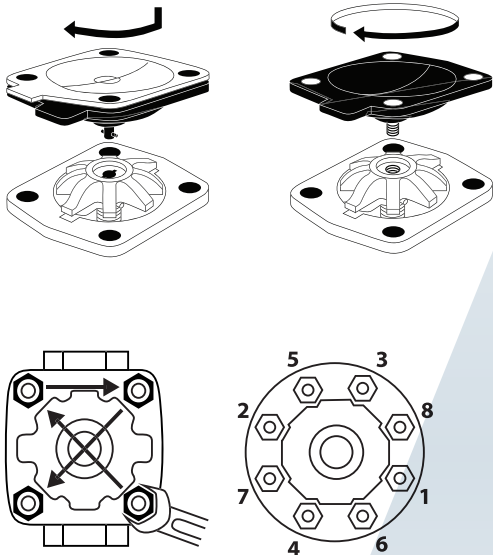

Valve Size DN	Weir Types	
	lbf.ft	lbf.ft
8	2,2	3
10	3	4
15	5	6,6
20	5	6,6
25	6	8
32	8	11
40	13	17
50	24	33
65	35	47
80	49	67
100	39	53
125	44	60
150	79	107
200	96	130
250	107	145
300	122	165
350	122	165
400	122	165
450	122	165
500	122	165

Valve Size DN	Straight Through Types	
	lbf.ft	lbf.ft
15	5	6,6
20	5	6,6
25	11	15
32	11	15
40	12	16
50	24	33
65	30	40
80	44	60
100	39	53
125	39	53
150	79	107
200	96	130
250	107	145
300	122	165
350	122	165

How can I maintain my Saunders® diaphragm?

The Saunders® Industrial Diaphragm Valve is designed in such a way that enables in-line maintenance; disassembly, inspection and reassembly without removing the valve body from the pipeline. For full instructions on diaphragm installation, please refer to our installation and operating manual, and take note of the points raised in this FAQ section.

How long will my Saunders® diaphragm last?

The lifetime of Saunders® diaphragms in service is dependant on a number of factors including process media concentration, operating temperature and correct installation, such that is impossible to provide a definitive answer to this question. Saunders recommends that for most applications with some level of aggressive media present, diaphragms should be replaced every 3-5 years as part of a regular preventative maintenance program.

What approvals do you offer on the new Saunders® diaphragms?

Approvals differ based on region and diaphragm grade. To find out whether we can offer the approval you require please contact us at IDVexperts@cranecpe.com

FREQUENTLY ASKED QUESTIONS

What fitment types for diaphragms are offered by Saunders®?

We offer three kinds of fitments for our diaphragms which are dictated by diaphragm size and material. The images below show each type and their respective sizes and materials.

Button Fit



- A Type
- Material: Elastomers
- Size Range: DN8–DN10 - two bolt
- Material: PTFE
- Size Range: DN8–DN10

Screw Fit

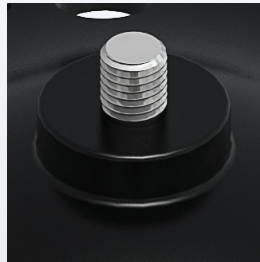

- A & KB Type
- Material: Elastomers
- Size Range: DN15 - DN350 – four bolt

Bayonet Fit



- A Type
- Material: Fluoropolymer (PTFE)
- Size Range: DN15 – DN250 - four bolt

How can I trace my Saunders® diaphragm?

We mark all of our Saunders® diaphragms with the material grade, size, year and week of manufacture so we can retrospectively identify the exact batch of material from which that particular Saunders® diaphragm was produced. This, coupled with the rigorous physical property testing which occurs during various manufacturing stages allows us to provide our customers with the complete confidence that we are in total control of the quality of our Saunders® diaphragms.

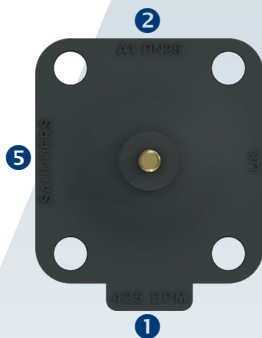

- 1 Material Grade
- 2 Size (placement may vary)
- 3 Week of manufacture
- 4 Year of manufacture
- 5 Saunders®

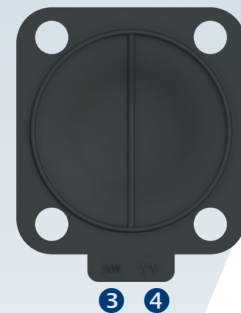

How do I configure my diaphragm ordering code?

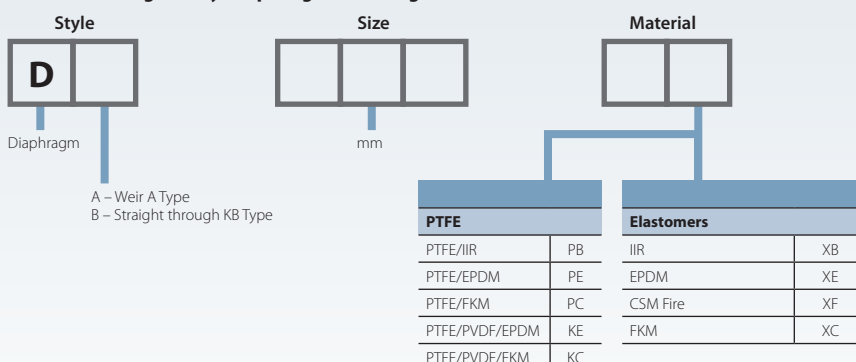



Crane ChemPharma & Energy

Crane Process Flow Technologies Ltd.

Grange Road

Cwmbran, Gwent NP44 3XX

UNITED KINGDOM

Tel: +44 1633 486666

Fax: +44 1633 486777

www.cranecpe.com

CRANE

Crane Process Flow Technologies
SPRL / BV
Avenue Franklin No. 1
Wavre, B-1300 , Belgium
Tel: +32 10 8184 44
Fax: +32 10 8184 58

Crane ChemPharma & Energy
4526 Research Forest Dr, Suite 400,
The Woodlands, TX 77381 • USA
Tel: (936)-588-8360

Crane Process Flow Technologies (India) Ltd
Solitaire, 5th & 6th Floor, S.No. 131 / 1+2 ,
ITI Road, Aundh, Pune - 411007, India
Tel: +91 20 3056 7800
Fax: +91 20 3056 7812

Need Technical assistance? Ask the experts.
IDVexperts@cranecpe.com

brands you trust.



COMPAC-NOZ



DEPA

ELRO **DUO-CHEK**



NOZ-CHEK



RESISTOFLEX



STOCKHAM



UNI-CHEK

w.ta.

XOMOX

Crane Co., and its subsidiaries cannot accept responsibility for possible errors in catalogues, brochures, other printed materials, and website information. Crane Co. reserves the right to alter its products without notice, including products already on order provided that such alteration can be made without changes being necessary in specifications already agreed. All trademarks in this material are property of the Crane Co. or its subsidiaries. The Crane and Crane brands logotype, in alphabetical order, (ALOYCO®, CENTER LINE®, COMPAC-NOZ®, CRANE®, DEPA®, DUO-CHEK®, ELRO®, FLOWSEAL®, JENKINS®, KROMBACH®, NOZ-CHEK®, PACIFIC VALVES®, RESISTOFLEX®, REVO®, SAUNDERS®, STOCKHAM®, TRIANGLE®, UNI-CHEK®, WTA®, and XOMOX®) are registered trademarks of Crane Co. All rights reserved.