

# INSTALLATION, OPERATION AND MAINTENANCE MANUAL

**REDUCING MAINTENANCE & INSTALLATION TIME BY 50%**

## **SAUNDERS**<sup>®</sup> **Hygenic Ball Valves**

**CRANE**<sup>®</sup>

**v in** [www.cranecpe.com](http://www.cranecpe.com)

# Content

The SAUNDERS<sup>®</sup> Sanitary Ball Valve series is a Class 300 Quarter Turn Floating Ball Valve Design. When mounted with an actuator the ball valve cartridge can be removed without removal of the actuator and sensor.



## TABLE OF CONTENT

<b>Basic Instructions</b>	<b>3</b>
<b>1 1. Product Structure</b>	
<b>1.1. Actuator operated Product Structure</b>	<b>4</b>
<b>1.2. Manual Lever Product Structure</b>	<b>5</b>
<b>2 2. Installation</b>	<b>6</b>
<b>2.2.1 Removing Actuator</b>	<b>6</b>
<b>2.2.2. Actuator Assembly</b>	<b>6</b>
<b>2.2.3. Handle Assembly / Disassembly</b>	<b>7</b>
<b>2.2.4. Seat/ Cartridge Replacement</b>	<b>8</b>
<b>2.2.5. Cartridge Installation</b>	<b>9</b>
<b>3 Actuator Connection Description</b>	<b>10</b>
<b>4 Technical data</b>	<b>11</b>
<b>4.1. Working Data</b>	<b>11</b>
<b>4.2. Mechanical Data</b>	<b>11</b>
<b>4.3. Pneumatic Data</b>	<b>11</b>
<b>5 Trouble Shooting</b>	<b>12</b>
<b>6 Notes</b>	<b>13</b>

## Basic Instructions

These instructions do not make allowance for: Contingencies and events, which may arise during the installation, operation, and maintenance of the valve.

Local safety regulations: the operator is responsible for observing these regulations, also with reference to the installation personnel.

### High Pressure

Before dismounting pneumatic lines and valves, turn off the pressure and vent the lines. To prevent damage, make sure that all the pneumatics connections are made correctly. Before removing, a valve from the line ensure the line is depressurized and drained. The valve should be cycled to relieve any pressure that could be trapped in the body/ball.

### Moving Parts (Risk of Amputation)

The ball valve is a quarter turn actuator. Provisions must be made by the user to ensure the valve cannot be operated unintentionally. All personnel are restricted from inserting fingers or objects into the bore whilst the actuators are live. Accidental pressurization of the actuator whilst bore is exposed can result in serious harm.

### Electrical Risks

Observe applicable accident prevention and safety regulations for electrical equipment.

 **WARNING**

**Do not connect or disconnect (equipment/sensors) while circuit is live unless location is known to be non-hazardous.**

### Hazardous Situation

To avoid injury, ensure:

- That the system cannot be activated unintentionally.
- Installation and maintenance may be carried out by authorized technicians only.
- After an interruption in the power or pneumatic supply, ensure that the process will be restarted in a defined and controlled manner.
- The valve must be operated according to the operating instructions

# Overview

## Product Structure

### 1.1. Actuator operated Product Structure

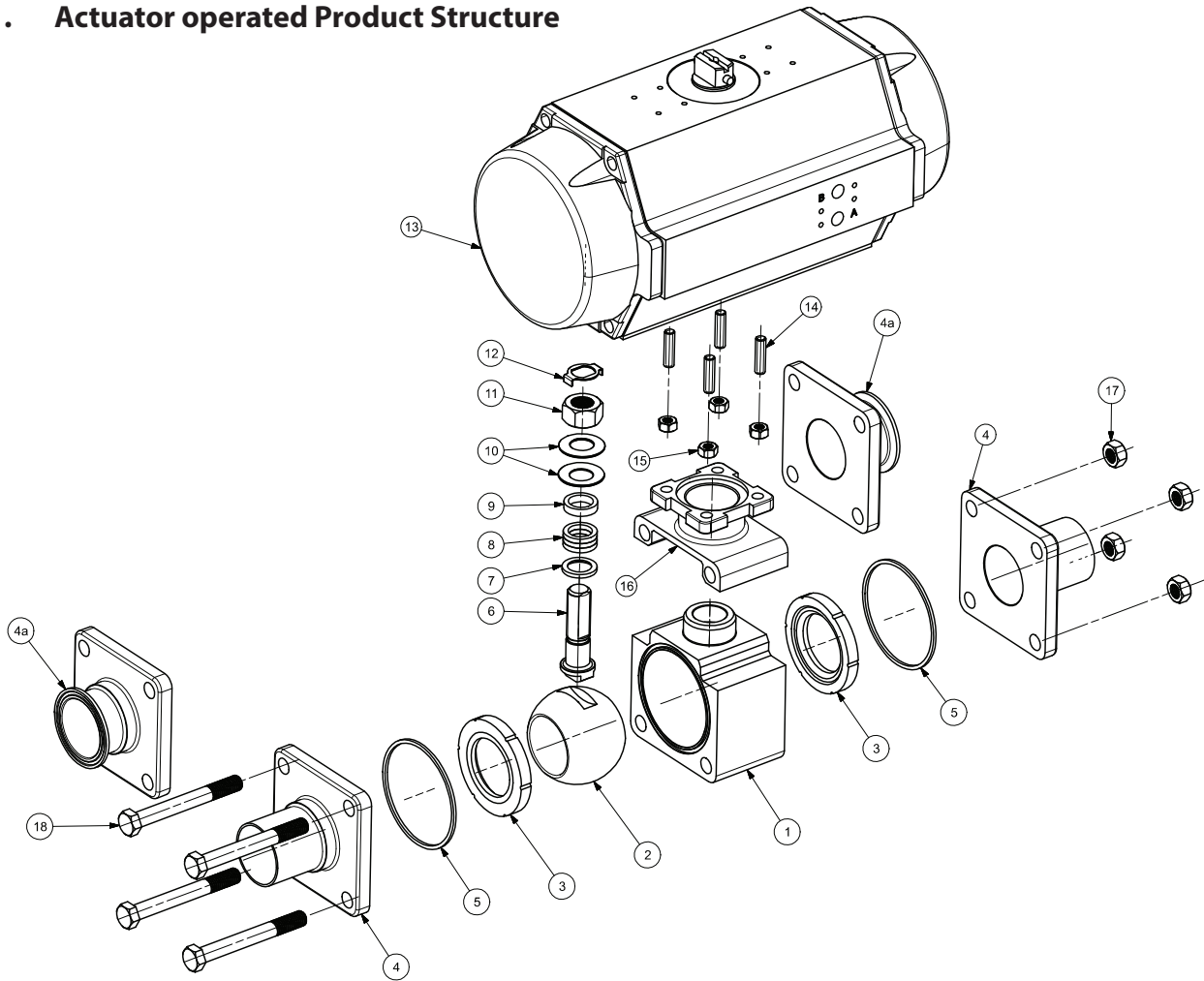

**Figure 1. Ball Valve Structure**

ITEM NO.	DESCRIPTION	QTY
1	Body	1
2	Ball	1
3	Seat	2
4	End connection (bw)	2
4a	End connection (tc)	2
5	Body seal	2
6	Stem	1
7	Primary stem seal	1
8	Stem packing	3
9	Gland	1

ITEM NO.	DESCRIPTION	QTY
10	Belleville washer	2
11	Hex nut	1
12	Nut lock tab	1
13	Actuator	1
14	Actuator stud	4
15	Actuator nut	4
16	Top adapter	1
17	Body hex nut	4
18	Body hex bolt	4

## Product Structure

### 2.1. Manual Lever Product Structure

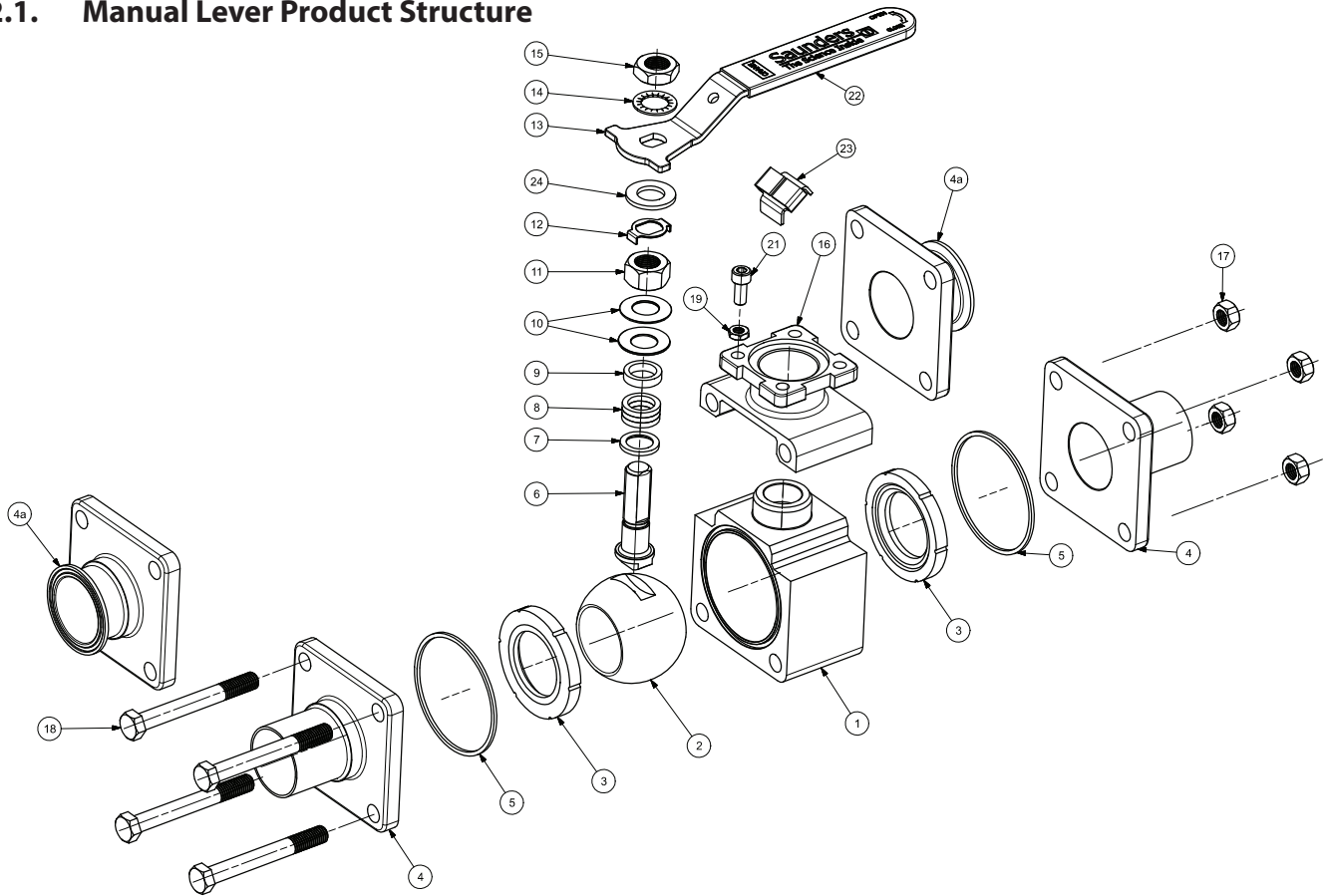

**Figure 2. Ball Valve Structure**

ITEM NO.	DESCRIPTION	QTY
1	Body	1
2	Ball	1
3	Seat	2
4	End connection (bw)	2
4a	End connection (tc)	2
5	Body seal	2
6	Stem	1
7	Primary stem seal	1
8	Stem packing	3
9	Gland	1
10	Belleville washer	2
11	Hex nut	1

ITEM NO.	DESCRIPTION	QTY
12	Nut lock tab	1
13	Lever	1
14	Lever lock washer	1
15	Lever hex nut	1
16	Top adapter	1
17	Body hex nut	4
18	Body hex bolt	4
19	Lever stop hex nut	1
21	Lever stop cap screw	1
22	Lever sleeve	1
23	Lever lock	1
24	Lever flat washer	1

## Ball Valve Installation

### 2. Installation

#### 2.2.1 Removing Actuator

1. Remove the 4 off M6 nuts using a 10mm spanner provided

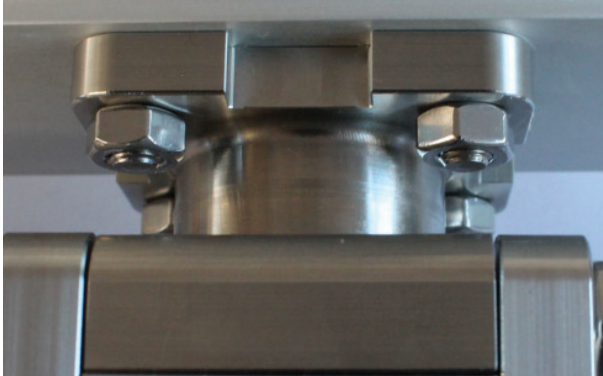

2. Remove actuator

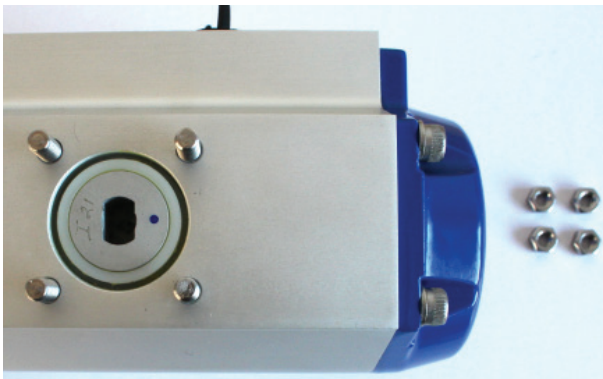

3. Ensure 4 off M6 studs are fully engaged into the actuator

#### 2.2.2. Actuator Assembly

1. Ensure 4 off M6 studs are fully engaged into the actuator

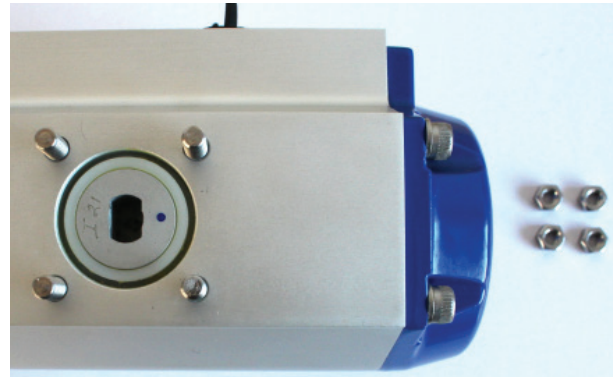

2. Ensure Stem is in the Correct Orientation for the Actuator



3. Place actuator onto adapter piece and secure using 4 M6 nuts

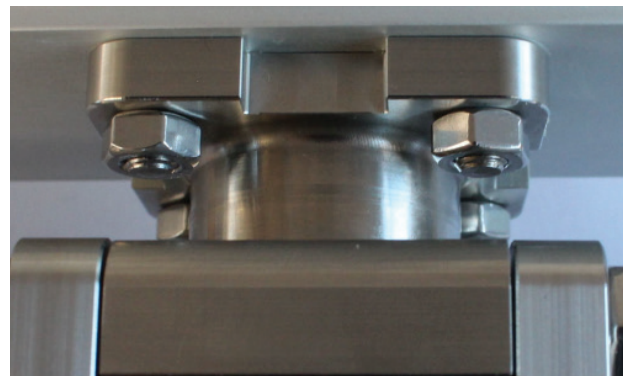

# Ball Valve Installation

## 2.2.3 Handle Assembly/Disassembly

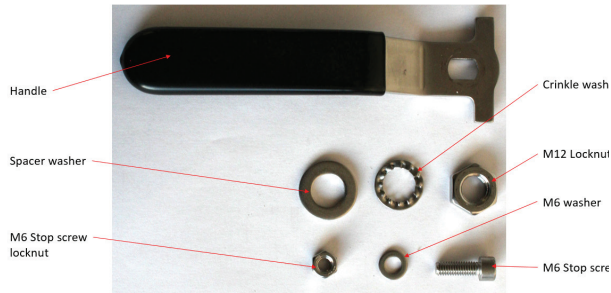

1. Fit M6 stop screw. The screw location is bottom right with the valve in line with the flow.

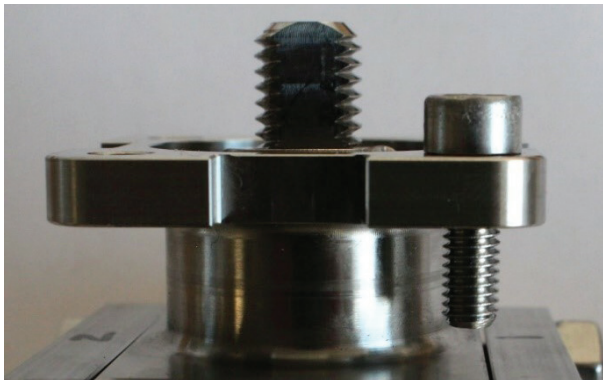

2. Fit M6 washer & M6 stop screw locknut

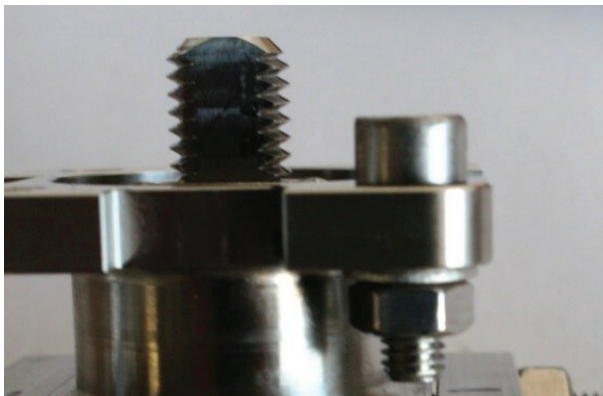

3. Fit spacer washer over locknut locking washer



4. Locate handle over stem

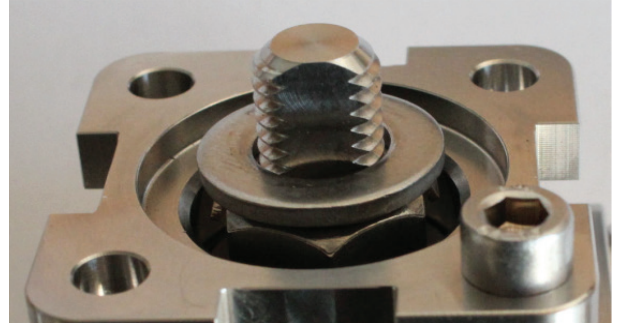

5. Fit locking washer over handle

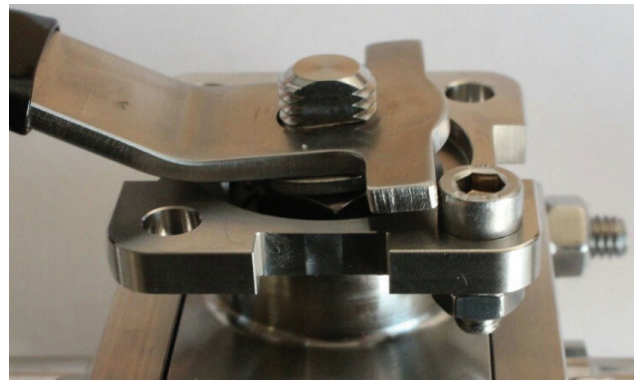

6. Fit M12 locknut using 19mm spanner provided

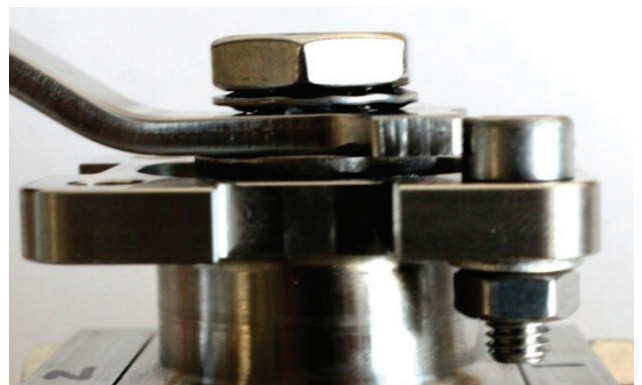

## Ball Valve Installation

### 2.2.4 Seat/ Cartridge Replacement

1. Loosen the top M8 fastenings using the 2 off 13mm spanners provided

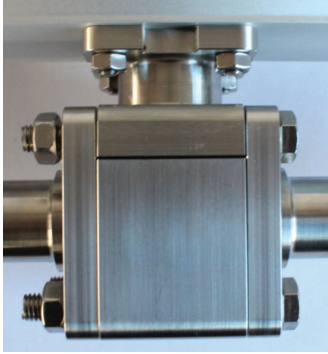

2. Remove the bottom fastenings using the 13mm spanners provided

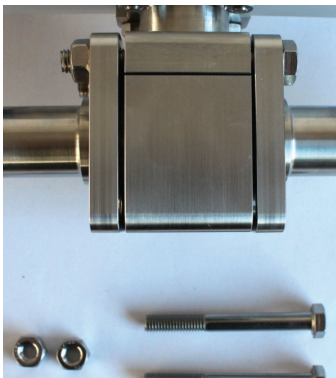

3. Withdraw the Cartridge (centre section)

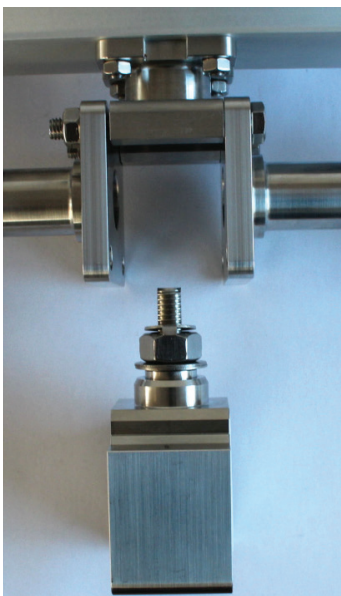

4. Remove seats

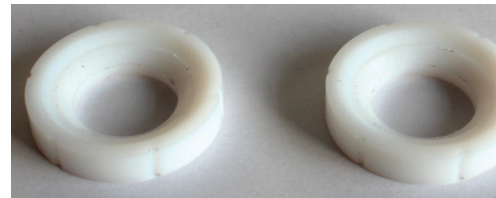

5. Fit replacement seats. Ensure correct orientation of seats

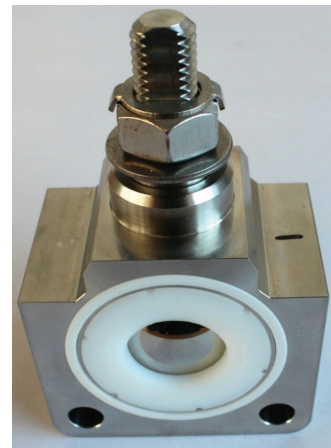



## Ball Valve Installation

### 2.2.5. Cartridge Installation

6. Ensure correct orientation of stem. Stem drive flats to be positioned perpendicular to main bore

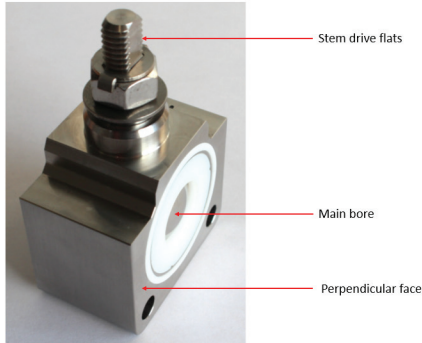

9. Tighten the upper M8 fastenings (metal to metal) using the 10mm spanners supplied

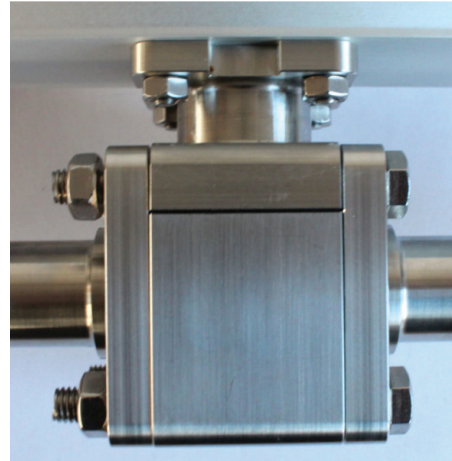

7. Insert cartridge/centre section into main body

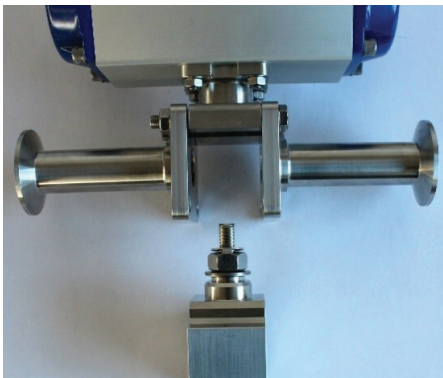

8. Fit and tighten the lower M8 fastenings (metal to metal) using the 10mm spanners supplied

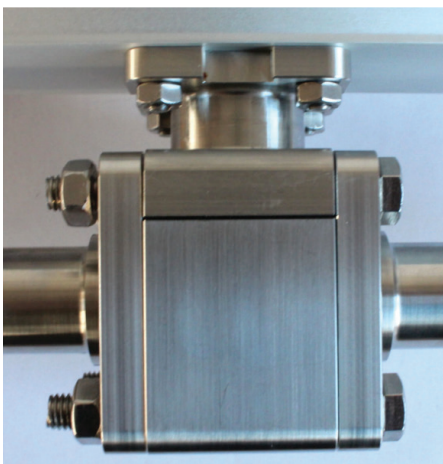

# Actuator Connection Description

## Pneumatic Valve Actuator, Series R

Air connections double-acting  
Air supply to port A: anti-clockwise/open

Air connections with spring reset  
Air supply to port A: anti-clockwise/open

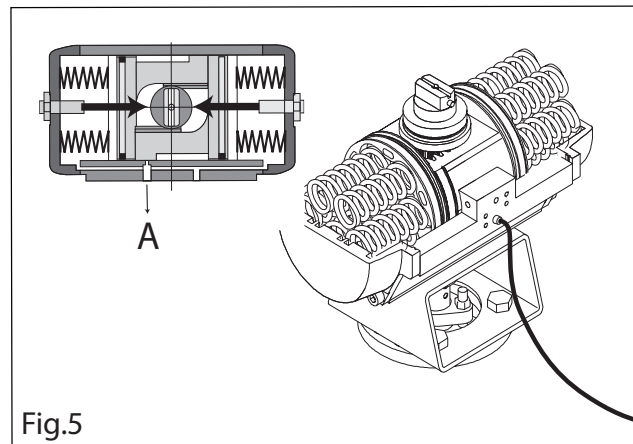
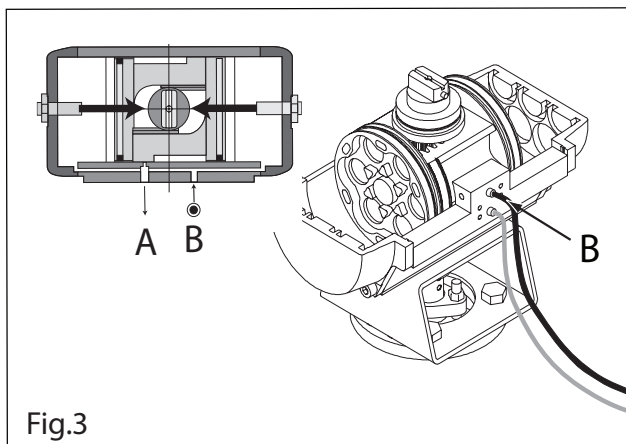
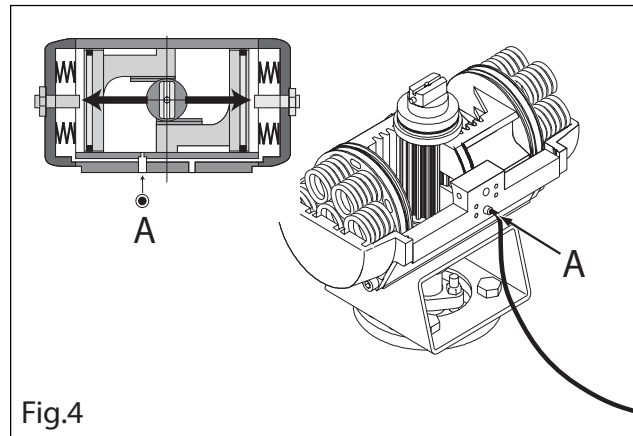
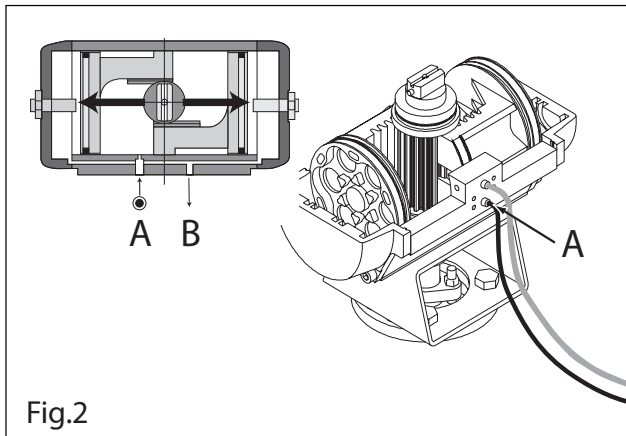

## Recommended Pipe Diameters for Compressed Air Lines

Actuator size	up to 1.20 m	longer than 1.20 m, max. upto 6 m
001 - 025	6 mm	6 mm
050 - 180	8 mm	8 mm
205 - H15	10 mm	15 mm

**⚠ WARNING**

1. Exceeding maximum actuator head pressure may result in damage.
2. Incorrect connection may cause damage.
3. Refer to Actuator IOM for additional information and safety requirements.

### 4. Technical data

#### 4.1. Working data

Ambient temperature: 0~70°C

Class rating: Class 300

#### 4.2. Mechanical data

**Body material:** Stainless Steel 316

**Sealing material:** TFM – modified polytetrafluoro-ethylene (PTFE)

#### 4.3. Pneumatic data

Refer to REVO Actuator IOM

### 5. Attention

These instructions do not make allowance for:

- Contingencies and events, which may arise during the installation, operation, and maintenance of the valve.
- Local safety regulations: the operator is responsible for observing these regulations, also with reference to the installation personnel.

#### High Pressure

Before dismounting pneumatic lines and valves, turn off the pressure and vent the lines. To prevent damage, make sure that all the pneumatics connections are made correctly. Before removing, a valve from the line ensure the line is depressurized and drained. The valve should be cycled to relieve any pressure that could be trapped in the body/ball.

#### Moving Parts (Risk of Amputation)

The ball valve is a quarter turn actuator. Provisions must be made by the user to ensure the valve cannot be operated unintentionally. All personnel are restricted from inserting fingers or objects into the bore whilst the actuators are live. Accidental pressurization of the actuator whilst bore is exposed can result in serious harm.

#### Electrical Risks

Observe applicable accident prevention and safety regulations for electrical equipment.

#### WARNING

**Do not connect or disconnect (equipment/sensors) while circuit is live unless location is known to be non-hazardous.**

#### Hazardous Situation

To avoid injury, ensure:

- That the system cannot be activated unintentionally.
- Installation and maintenance may be carried out by authorized technicians only.
- After an interruption in the power or pneumatic supply, ensure that the process will be restarted in a defined and controlled manner.
- The valve must be operated according to the operating instructions

## Trouble Shooting

Problem Observed	Potential Cause	Solution
Leakage at Stem	Loss of packing compression	Inspect the Belleville washers for damage. If condition is good, remove locking tab, tighten the gland nut to fully compress Belleville washers, then back the nut off by 1/16th of a turn and realign with locking tab.
		If damage is noted, dismantle valve stem assembly to gland, then replace disk springs in series with outer edges touching (doubles deflection). Replace gland nut and retighten.
	Damage/wear to packing/primary stem Seal	Full tear down and replacement of damaged/worn components
Leakage at body (Body seal)	Loss of body seal compression	Check tightness at body bolting connections. If loose, retighten.
		If leakage continues to occur, dismantle the valve in a safe condition and replace body seals.
Leakage in-line/downstream	Ball/stem misalignment	Ensure the valve is fully closing and orientation of stem is correct
	Ball/Seat damage	If leakage occurs downstream in the closed position, the seat or ball may be damaged. In this instance, the parts should be replaced. Maintenance of these components requires dismantling of valve in a safe condition.
Cartridge to actuator fitment issues	Stem to actuator misalignment	Ensure stem is aligned with actuator double D slot.
Cartridge does not eject from top adapter	Lower end connection to body bolts still fitted	Remove low end connection body bolts
	Top end connection to top adapter bolts too tight	Ensure top two end connection nuts have been slackened to facilitate removal
Lever fouling on ISO actuator mounting flange	Spacer washer missing	Place spacer washer between lever and locking washer
Loose lever	Serrated lock washer missing	Place serrated lock washer between lever and securing nut and retighten
	Securing nut loose	Tighten securing nut





---

**CRANE CHEMPHARMA & ENERGY**

Crane Process Flow Technologies Ltd.  
Grange Road  
Cwmbran, Gwent  
NP44 3XX, United Kingdom  
Tel: +44 1633 486666

---

Crane Co., and its subsidiaries cannot accept responsibility for possible errors in catalogues, brochures, other printed materials, and website information. Crane Co. reserves the right to alter its products without notice, including products already on order provided that such alteration can be made without changes being necessary in specifications already agreed. All trademarks in this material are the property of the Crane Co. or its subsidiaries. The Crane and Crane brands logotype (CENTER LINE®, COMPAC-NOZ®, CRANE®, DEPA® & ELRO®, DOPAK®, DUO-CHEK®, FLOWSEAL®, GYROLOK®, GO REGULATOR®, HOKE®, JENKINS®, KROMBACH®, NOZ-CHEK®, PACIFIC VALVES®, RESISTOFLEX®, REVO®, SAUNDERS®, STOCKHAM®, TEXAS SAMPLING®, TRIANGLE®, UNI-CHEK®, VALVES®, WESTLOCK CONTROLS®, WTA®, and XOMOX®) are registered trademarks of Crane Co. All rights reserved.