

TECHNICAL DATASHEET

MAXIMIZING VALVE LIFE IN EXCESS OF 3 MILLION CYCLES

SAUNDERS ANGLE SEAT VALVES

APU/AKU SERIES (ASME BPE)

Normally Closed/Normally Open/Double Acting

Contents

Materials of Construction.....Page 2

Dimensions.....Pages 3-4

Installation and Orientation..... Page 5

Actuator Selection/Performance Graphs.....Page 6 - 17

Product Coding/How to Order.....Pages 18-19

Product Breakdown

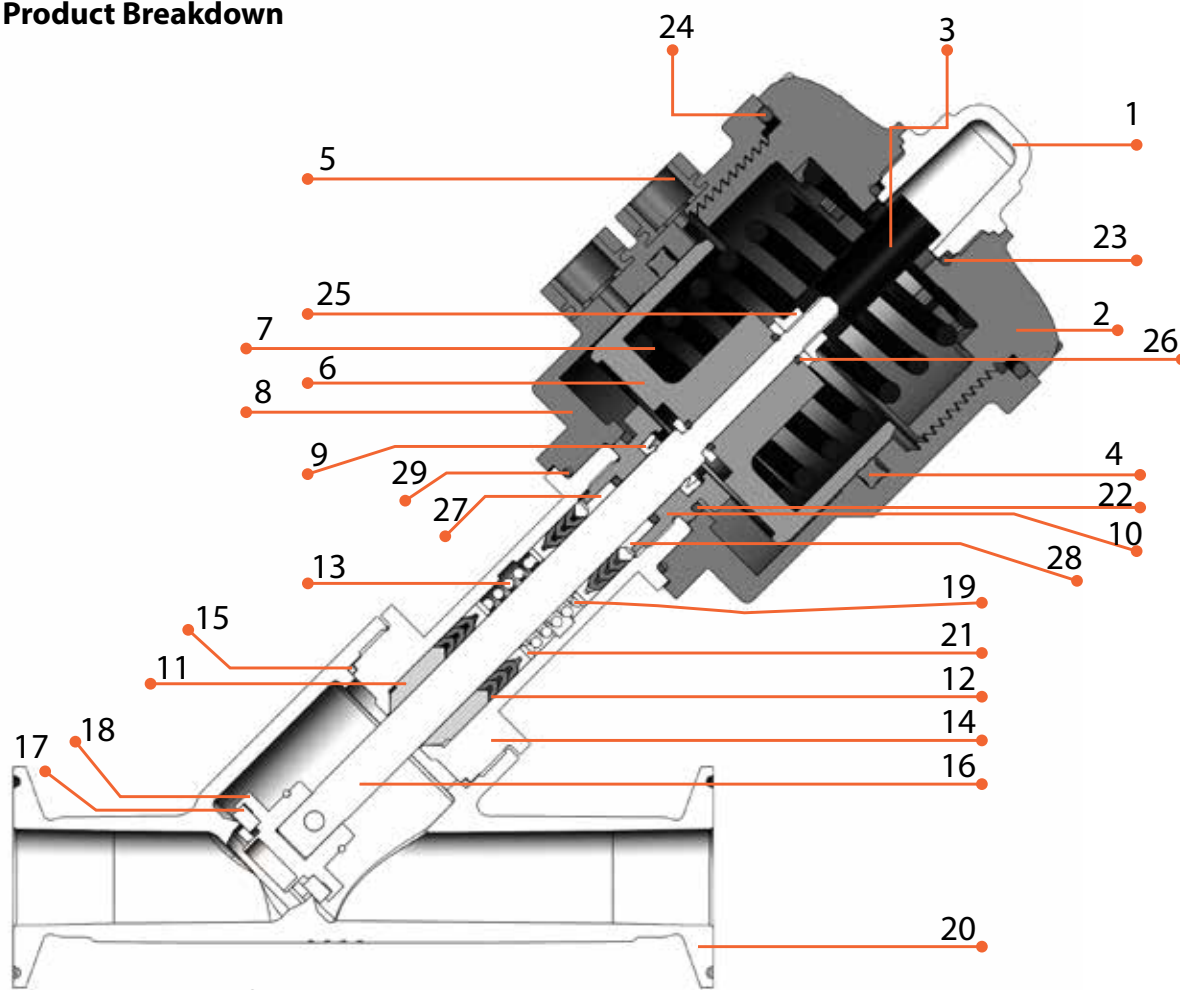

Cross section view

Components

Sr. no	DESCRIPTION	MATERIAL	Pos. No.	Qty.
1	Body	CF3M (SS316L)	20	1
2	Indicator Dome	Polycarbonate	1	1
3	Operator Cover	Glass filled Nylon	2	1
4	Open Indicator	ABS	3	1
5	Piston Seal	NBR	4	1
6	Insert	SS316L	5	2
7	Piston	Aluminium Anodised	6	1
8	Piston Spring	Carbon Steel (IS4454 GR II)	7	1
9	Piston Inner Spring	Carbon Steel (IS4454 GR II)	7A	1
10	Operator	Glass filled Nylon	8	1
11	Shaft Seal	NBR	9	1
12	Hex Assembly	Aluminium hard Anodised	10	1
13	Shaft bearing	PTFE/PEEK	11	1
14	Gland Packing	PTFE/PEEK	12	6
15	Gland Spring	SS 302	13	1
16	Sleeve	CF3M (SS316L Cast- 1.4435)	14	1
17	Body Seal	PTFE	15	1
18	Shaft	SS316L (1.4404)	16	1
19	Washer	SS 304	21	2
20	Gland Packing Retainer	PTFE	19	1
21	Operator Seal	NBR	22	1
22	Dome Nut Seal	NBR/Viton	23	1
23	Operator Cover Seal	NBR/Viton	24	1
24	Hex Flange Nut	Zinc	25	1
25	Seal	NBR/Viton	26	2
26	Bush	PTFE	27	1
27	Bush Seal	NBR/Viton	28	1
28	Sleeve Seal	NBR/Viton	29	1
29	Seat holder assembly	SS 316L	17	1
30	Retaining Ring	SS 302	18	1
31	Body Seal	PTFE	15	2
32	Shaft Seal	NBR	9	1
33	Operator Seal	NBR	22	1
34	Dome Nut Seal	NBR/Viton	23	1
35	Operator Cover Seal	NBR/Viton	24	1
36	Seal	NBR/Viton	26	2
37	Bush Seal	NBR/Viton	28	1
38	Sleeve Seal	NBR/Viton	29	1

Dimensions

APU Series (Butt Weld)

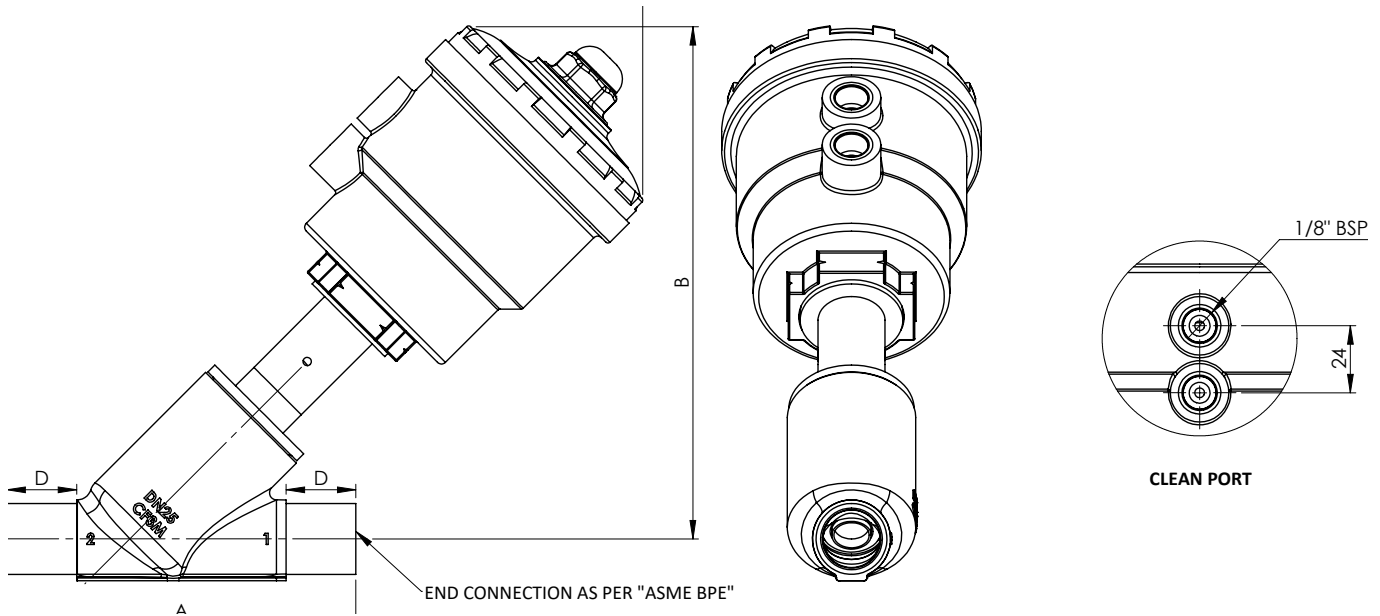

Series Number	Valve Size	Dimensions in mm			
		A	B	C	D
1	DN15	113	168	206	25
2	DN20	123	167	209	
3	DN25	125	184	228	
4	DN40	160	221	268	
5	DN50	180	271	325	

Dimensions

AKU Series (ASME BPE Hygienic Clamp)

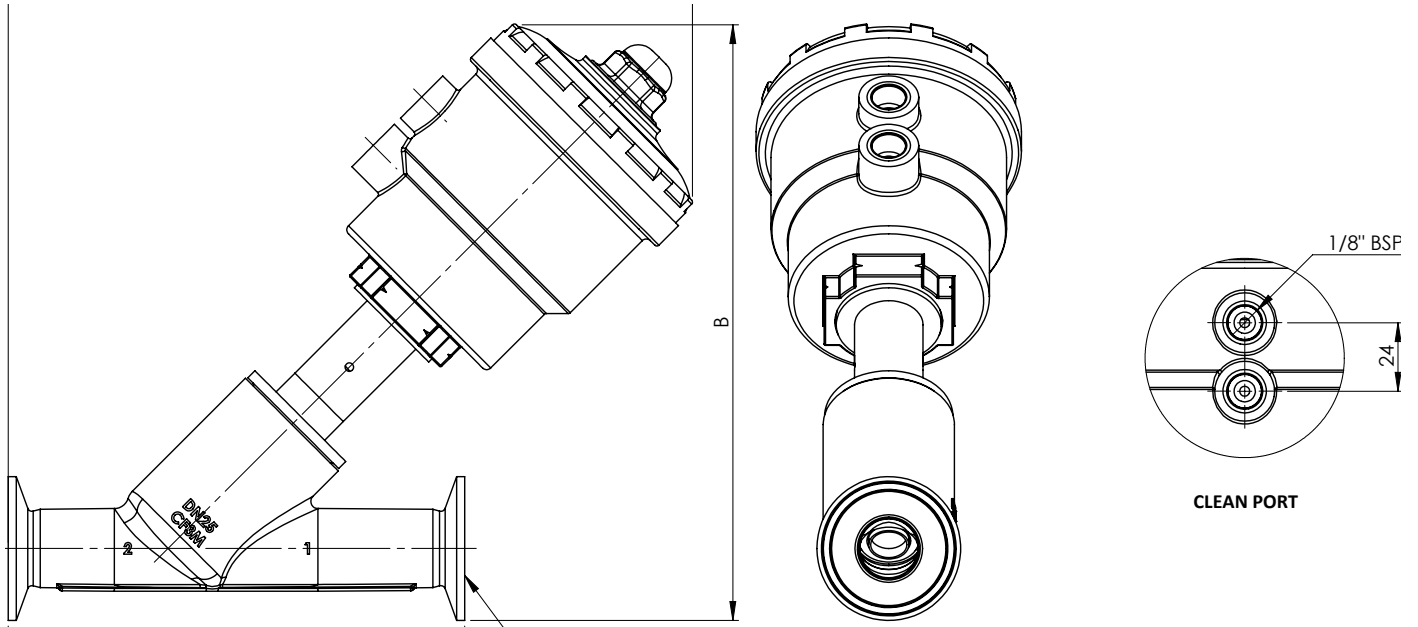

Series Number	Valve Size	Dimensions in mm		
		A	B	C
1	DN15	130	180	215
2	DN20	150	179	220
3	DN25	160	209	238
4	DN40	200	247	289
5	DN50	230	303	343

Product Overview

Installation and Recommended Flow Direction

Recommended flow direction is dependent on media type, operating mode of actuator and system requirements

Media Type

Liquid
Gas
Steam
Air
Vacuum

Operating Mode

Normally Close NC
Normally Open NO
Double Acting DA

Liquid based Media

For optimum service lifetime and avoidance of water hammer (liquid applications), recommended installation is with the media flow below the seat. If the valve is incorrectly installed with flow above the seat, water hammer may occur causing damage to the valve and functioning of the system. Flow over the seat may lead to increased wear and possible premature valve failure

Compressible Media

Compressible media, such as gases and steam, may be installed in either orientation but the recommended orientation is above the seat

Operating Air Pressure

Operating air pressure requirement will depend on the working line pressure, installation (flow direction over or under the seat), and actuator mode of operation. Please consult performance graphs for verification

Flow Orientation Indicators

To assist with optimum installation in accordance with above guidelines, "flow orientation indicators" are permanently marked on the body

- ❶ Inlet "Below Plug"
- ❷ Inlet "Above Plug"



Installation and Orientation

Normally Closed Actuator

RECOMMENDED INSTALLATION

PRESSURE ABOVE SEAT

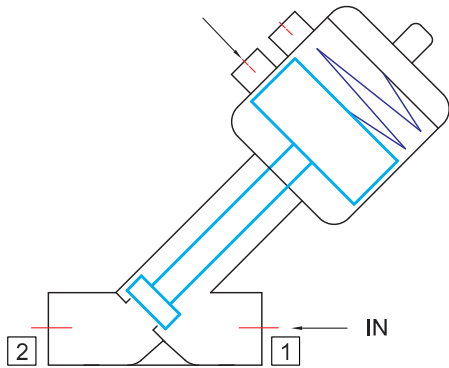

MEDIA

Gas, Steam, Air, Vacuum, LPG

PRESSURE BELOW SEAT

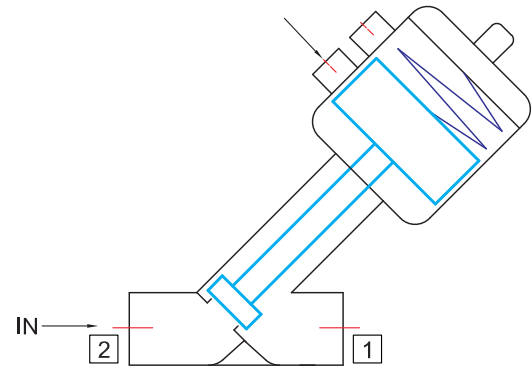

MEDIA

Gas, Air, Water, Vacuum, Oil, Liquid, Fuel

Normally Open Actuator

CONNECTION DETAIL/ RECOMMENDED INSTALLATION

PRESSURE BELOW SEAT

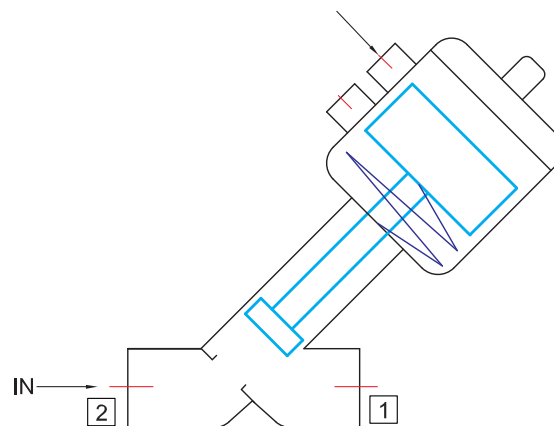

MEDIA

Steam, Air, Oil, Water, Fuel Gas and Liquid, Vacuum

Installation and Orientation

Double Acting Actuator

CONNECTION DETAIL/ RECOMMENDED INSTALLATION

**Normally close
Pressure Above Seat**

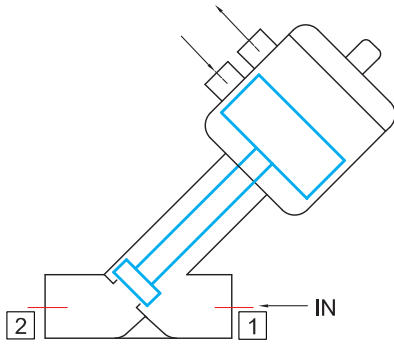

MEDIA

Gas, Steam, Air, Vacuum,
LPG

**Normally close
Pressure Below Seat**

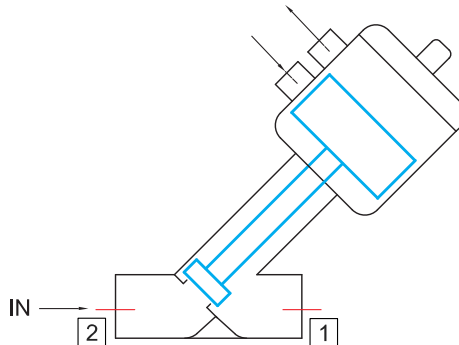

MEDIA

Gas, Air, Water, Vacuum, Oil,
Liquid, Fuel

**Normally open
Pressure Below Seat**

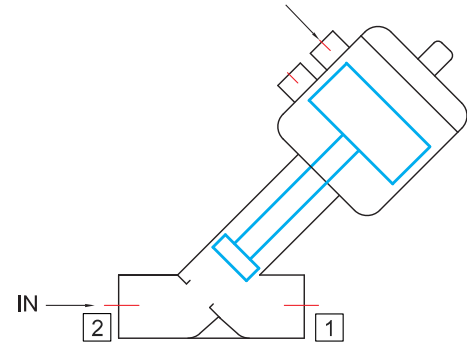

MEDIA

Steam, Air, Oil, Water, Fuel
Gas and Liquid, Vacuum

Pressure and Temperature Ratings

Valve Selection

When selecting the required configuration of Angle Seat Valve, the following factors should be taken into account:

- Process Media
- Operating and Ambient temperatures (min/max)
- Flow direction, mounting position and size
- Valve seat and gland packing seal dependent on process parameters and media
- Required mode of operation
 - Normally Open,
 - Normally Closed,
 - Double Acting
- Operating Air Pressure (min/max) for Actuator
- Compressed Air quality for pneumatically operated valves
- Please consult operating parameters on the following pages to validate correct actuator selection

PED

Angle Seat Valves intended to be installed in an area where PED is applicable

- Valve should be connected to a lower fluid pressure as indicated in the table below or as detailed in published operating parameters.

Pressure/Temperature Chart

Pressure and Temperature Chart								
DN	CLASS	MAXIMUM PRESSURE (bar)						PED Applicable
		-29° C to 38° C	50 °C	100 °C	150 °C	180 °C	200 °C	
15	B40	≤25	≤25	≤25	≤25	≤25	≤25	Not applicable
20	B40	≤25	≤25	≤25	≤25	≤25	≤25	Not applicable
25	B40	≤25	≤25	≤25	≤25	≤25	≤25	Not applicable
32	B25	≤24.5	≤23	≤20	≤19	≤18	≤17	Yes
40	B20	≤19.6	≤19	≤16	≤15	≤14	≤14	Yes
50	B25	≤24.5	≤23	≤20	≤19	≤18	≤17	Yes
65	B40	≤25	≤25	≤25	≤25	≤25	≤25	Yes
80	B40	≤15	≤15	≤15	≤15	≤15	≤15	Yes
Pressure Temperature Compatibility Chart (for AKU)								
DN	CLASS	MAXIMUM PRESSURE (bar)						PED Applicable
		-29° C to 38° C	50 °C	100 °C	121 °C	--	--	
15	B40	13.7	13.4	11.9	11.3	--	--	Not applicable
20	B40	13.7	13.4	11.9	11.3	--	--	Not applicable
25	B40	13.7	13.4	11.9	11.3	--	--	Not applicable
32	B25	13.7	13.4	11.9	11.3	--	--	Yes
40	B20	13.7	13.4	11.9	11.3	--	--	Yes
50	B25	13.7	13.4	11.9	11.3	--	--	Yes
65	B40	13.7	13.4	11.9	11.3	--	--	Yes
80	B40	13.7	13.3	11.2	10.3	--	--	Yes

Pressure and Temperature Ratings

Pressure Temperature Compatibility Chart (APU) 0								
DN	CLASS	MAXIMUM PRESSURE (bar)						PED Applicable
		-29° C to 38° C	50 °C	100 °C	150 °C	180 °C	200 °C	
15	B40	≤25	≤25	≤25	≤25	≤25	≤25	Not applicable
20	B40	≤25	≤25	≤25	≤25	≤25	≤25	Not applicable
25	B40	≤25	≤25	≤25	≤25	≤25	≤25	Not applicable
32	B25	≤24.5	≤23	≤20	≤19	≤18	≤17	Yes
40	B20	≤19.6	≤19	≤16	≤15	≤14	≤14	Yes
50	B25	≤24.5	≤23	≤20	≤19	≤18	≤17	Yes
65	B40	≤25	≤25	≤25	≤25	≤25	≤25	Yes
80	B40	≤15	≤15	≤15	≤15	≤15	≤15	Yes

Pressure Temperature Compatibility Chart (for AKU)								
DN	CLASS	MAXIMUM PRESSURE (bar)						PED Applicable
		-29° C to 38° C	50 °C	100 °C	121 °C	--	--	
15	B40	13.7	13.4	11.9	11.3	--	--	Not applicable
20	B40	13.7	13.4	11.9	11.3	--	--	Not applicable
25	B40	13.7	13.4	11.9	11.3	--	--	Not applicable
32	B25	13.7	13.4	11.9	11.3	--	--	Yes
40	B20	13.7	13.4	11.9	11.3	--	--	Yes
50	B25	13.7	13.4	11.9	11.3	--	--	Yes
65	B40	13.7	13.4	11.9	11.3	--	--	Yes
80	B40	13.7	13.3	11.2	10.3	--	--	Yes

Pressure Temperature Compatibility (PTFE/PEEK)

Pressure Temperature Compatibility Chart (for PTFE & PEEK material)								
DN (mm)	MATERIAL	MAXIMUM PRESSURE (bar)						
		-29° C to 38° C	50 °C	100 °C	150 °C	180 °C	200 °C	
15 to 80	PTFE	68	67	48	30	18	---	
65 to 80	PTFE	48	48	48	30	18	---	
12 to 50	PEEK	102	102	102	102	102	68	
65 to 80	PEEK	48	48	48	48	48	48	

Notes:

1. If valves are to be operated at a higher pressure, or reduced ambient/fluid temperature, refer to following tables or contact Saunders, stating the temperature limit at which the valve will operate.
2. Pressure temperature Compatibility chart derived from Table 30 of EN 12516-1. Operating Parameters are in accordance with Table 30 of EN 12516-1.
3. Pressure Temperature Compatibility Chart derived from Table DT-2 Hygienic unions of ASME BPE. Operating Parameters for (AK series) is in accordance with Table DT-2 Hygienic unions of ASME BPE.
4. For temperatures up to 180°C select PTFE (White) seat/seal. For temperatures above 180°C select PEEK (Virgin).

General Maintenance

General Maintenance

- Do not dismantle or loosen any valve components during service and always ensure that pressure is removed prior to any maintenance taking place to avoid damage to the valve or maintenance personnel.
- Do not perform maintenance on any valve in place. Remove valve from service and undertake maintenance under safe working conditions.
- Always ensure operating air supply is removed prior to removal of the valve from service.
- It is recommended that all seals are replaced in the event of a single seal failure. This will ensure trouble free operation and avoid premature failure.
- It is recommended that only Molykote 111 is used in seal lubrication. The use of any other form of grease will lead to premature failure of the seals.
- The use of a light soap detergent is recommended when cleaning of the valve is required. Do not use kerosene, diesel or petrol to clean.
- Always ensure all components are free from dust, dirt, lint or metal burrs.
- When fitting O-Rings ensure that they are free from twisting and pinching when assembling mating components to avoid damage and failure during service.
- Ensure during assembly that mating parts are pushed together without a twisting motion being applied. This will ensure no damage occurs.
- Genuine Saunders spare parts will ensure trouble free operation and avoid premature failure.
- Always follow the correct mounting/installation procedures when re-assembling valves.
- Use only recommended or specified line media during the operation of the valve to avoid damage to internal valve components and valve body.
- Avoid contact of the valve with excessive external heat, such as those associated with fire, to prevent damage to internal rubber components.

Torque Specification

Part no.	Part (NW)	Size	Torque (Nm)
16	15/20/25	M6 x 1.0	≤5
	32/40/50/65/80	M10 x 1.5	≤15
14	15	M28 x 1.5	≤90
	20	M32 x 1.5	≤100
	25	M40 x 1.5	≤120
	32/65/80	M48 x 1.5	≤135
	40	M58 x 1.5	≤150
	50	M70 x 2	≤200
	Flange nut-bolt (class-150/300) (NOTE-Stainless Steel having tensile strength greater than 52kg/mm ² or steel fastener grade 8.8 Or better.)	M14 x 2	≤40
		M18 x 2.5	≤90
		M20 x 2.5	≤140

Operating/Performance Parameters

Single Acting Normally Closed F1/F6

Single Acting Normally Closed F1/F6

Function	DN	Actuator Ø	Single acting Normally Closed Bi-Directional					
			F1: Pressure above plug			F6: Pressure below plug		
			Pilot Pressure	Fluid Pressure (bar)		Pilot Pressure	Fluid Pressure (bar)	
			Up to 10 bar	APU	AKU	Up to 10 bar	APU	AKU
F1	12	50	4.6	0	0	4.6	0	0
			5	16	16	4.4	16	16
			5.4	25		4.4	25	
F1	20	50	4.6	0	0	4.6	0	0
			5	6	6	4	8	8
			6	25	16			
F6	20	63	5.4	0	0	5.4	0	0
			5.6	16	16	4.9	16	16
			5.7	25		4.4	25	
F1	25	50	4.6	0	0	4.6	0	0
			5	2.3	2.3	4.2	5	5
			8.2	25	16			
F6	25	63	4.5	0	0	4.5	0	0
			5	7.5	7.5	4.4	11	11
			6.1	25	16			
F1	40	63	3	0	0	3	0	0
			5	5.5	5.5	2	2	2
			10	21	16			
F6	40	63	5.4	0	0	5.4	0	0
			8.4	12	12	4.8	4	4
			10	18				
F1	40	90	2.3	0	0	2.3	0	0
			4.2	16	16	1.4	1.4	1.4
			5.3	25				
F6	40	90	4.5	0	0	4.5	0	0
			5	7.5	7.5	4.4	8	8
			6.1	25	16			
F1	50	63	2.8	0	0			
			5	4	4			
			10	14	14			

Operating/Performance Parameters

Single Acting Normally Closed F1/F6

F1	50	90	2.3	0	0			
			5	9.5	9.5			
			9	25	16			
F6	50	90	6	0	0	6	0	0
			6.8	14	14	4.5	6	6
			7.5	25				
F1	50	110	1.4	0	0			
			4.2	16	16			
			5.8	25				
F6	50	110	4.5	0	0	4.5	0	0
			5	4	4	4.4	9	9
			7.3	25	16			

Single Acting Normally Closed F1/F6

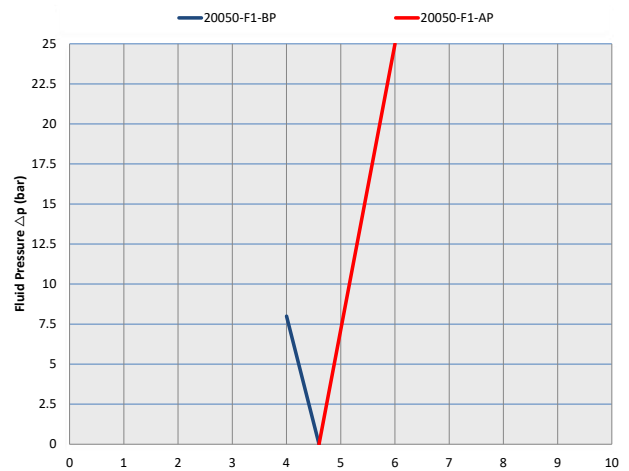
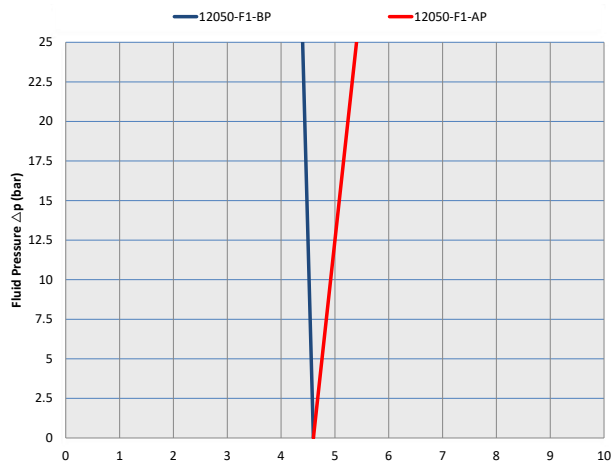

Operating/Performance Parameters

Single Acting Normally Closed F1/F6

Single Acting Normally Closed F1/F6

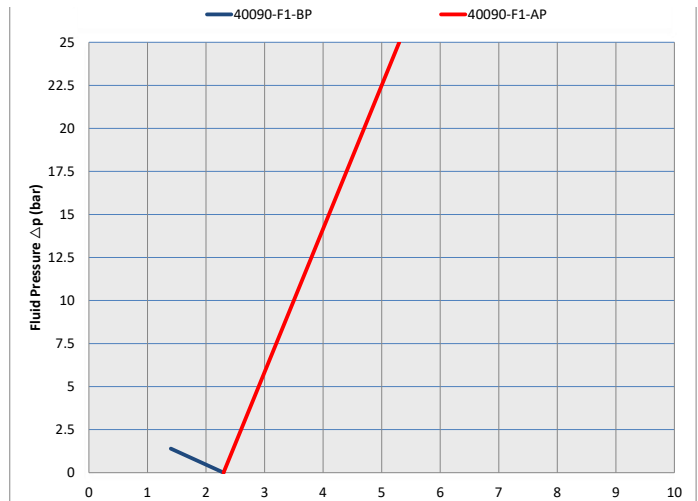
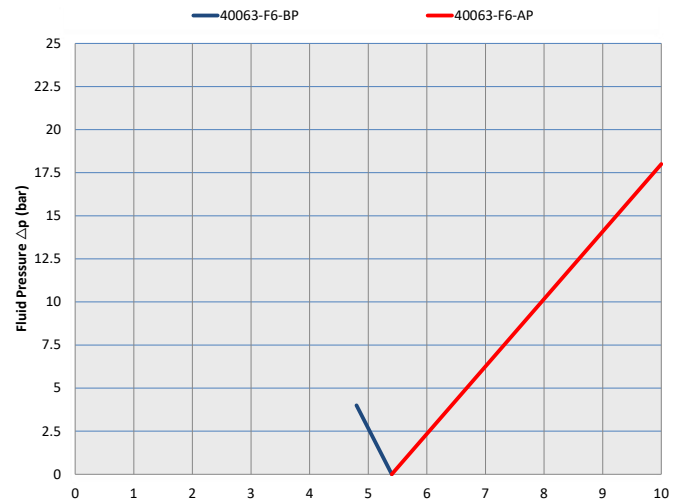
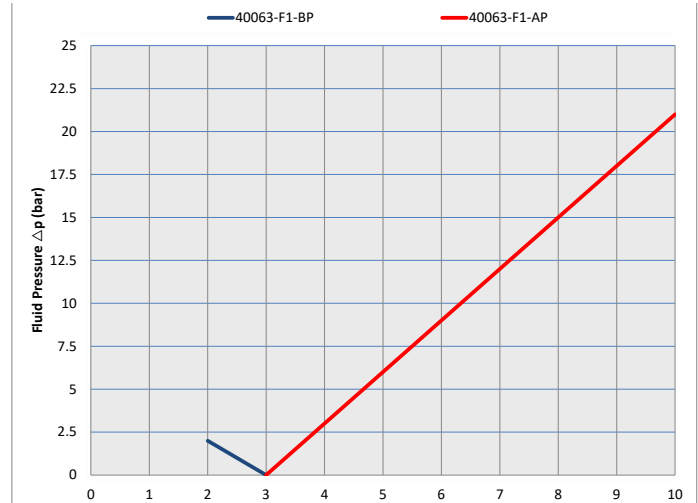
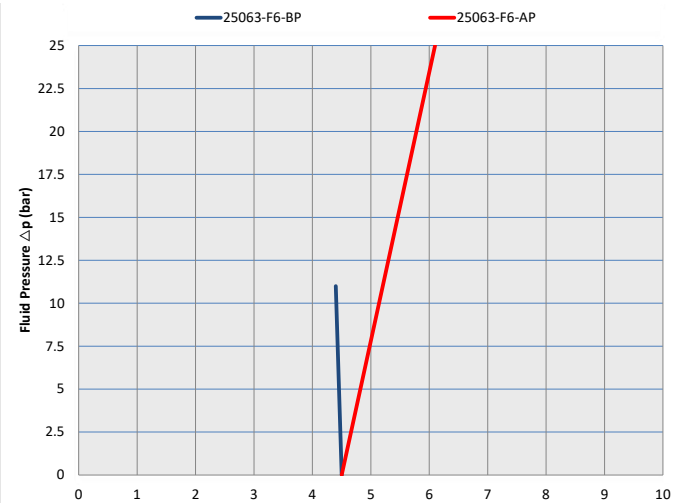
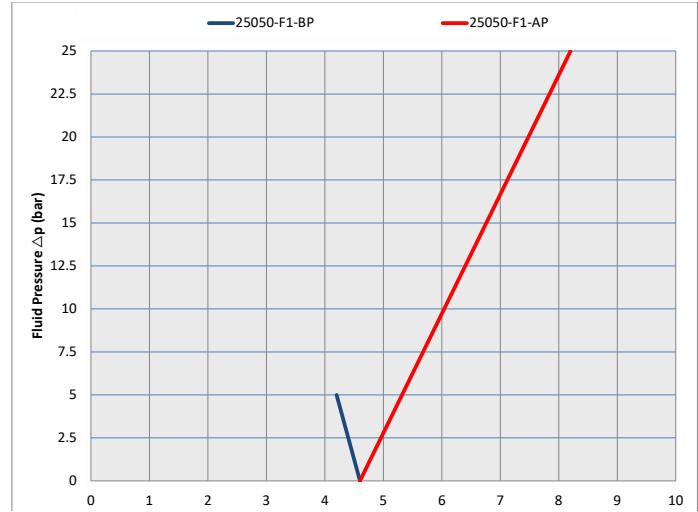
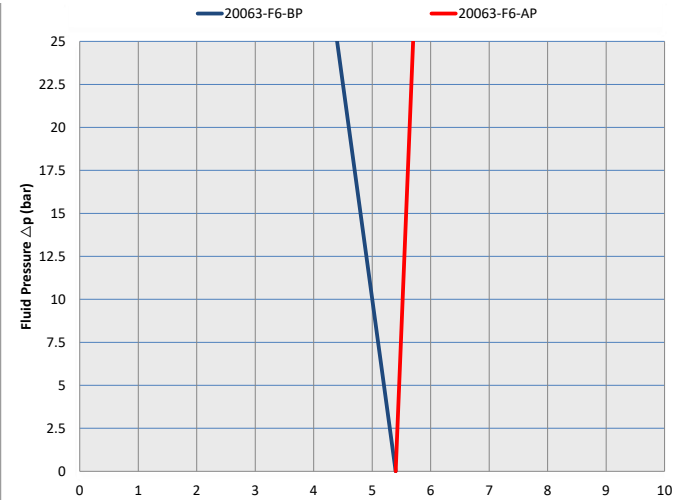

Operating/Performance Parameters

Single Acting Normally Closed F1/F6

Single Acting Normally Closed F1/F6

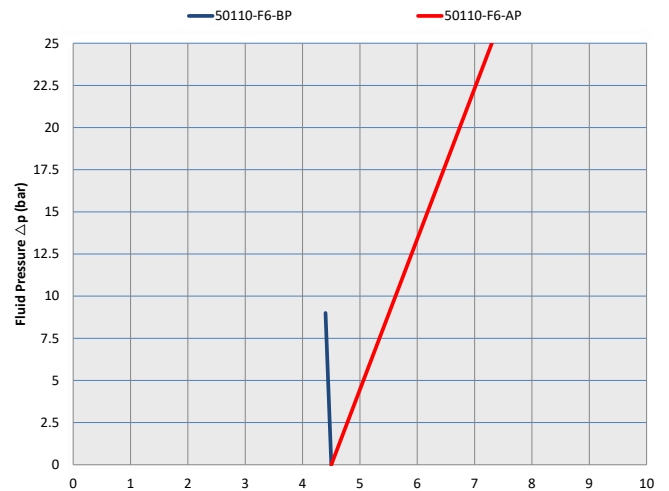
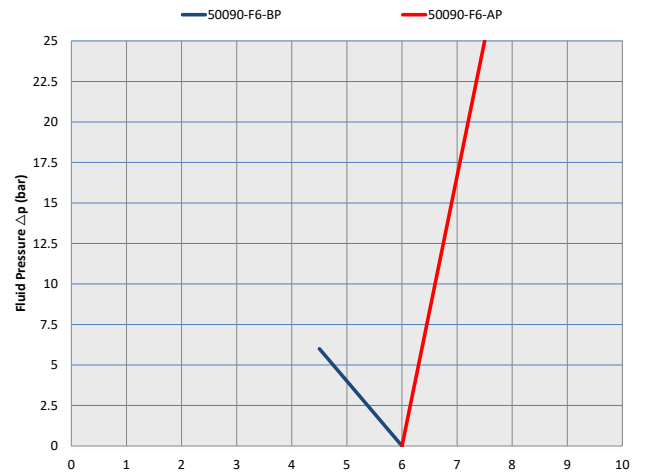
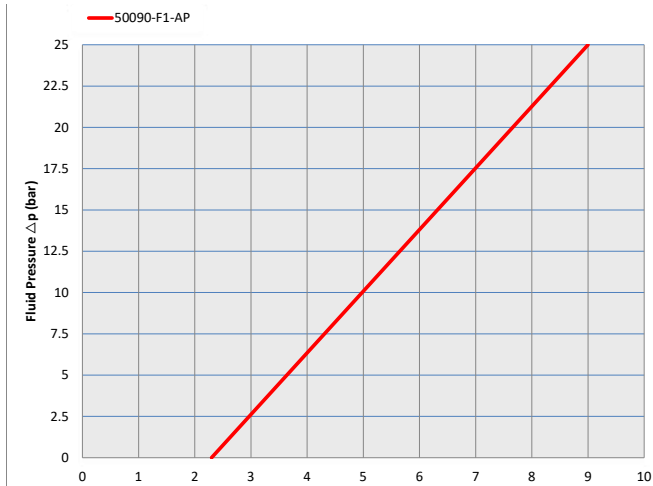
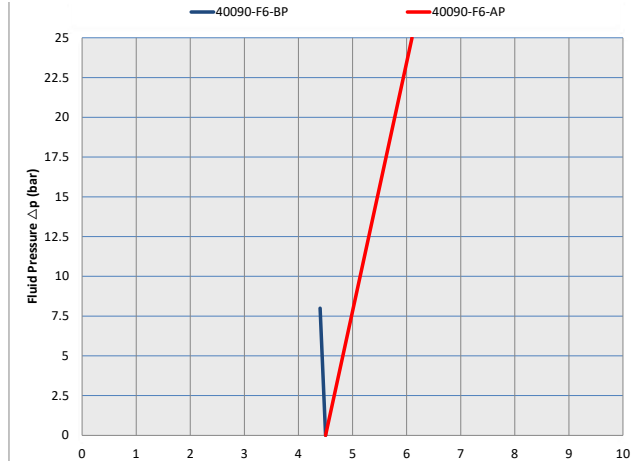

Coding

Single Acting Normally Closed F1/F6

Single Acting Normally Closed F1/F6

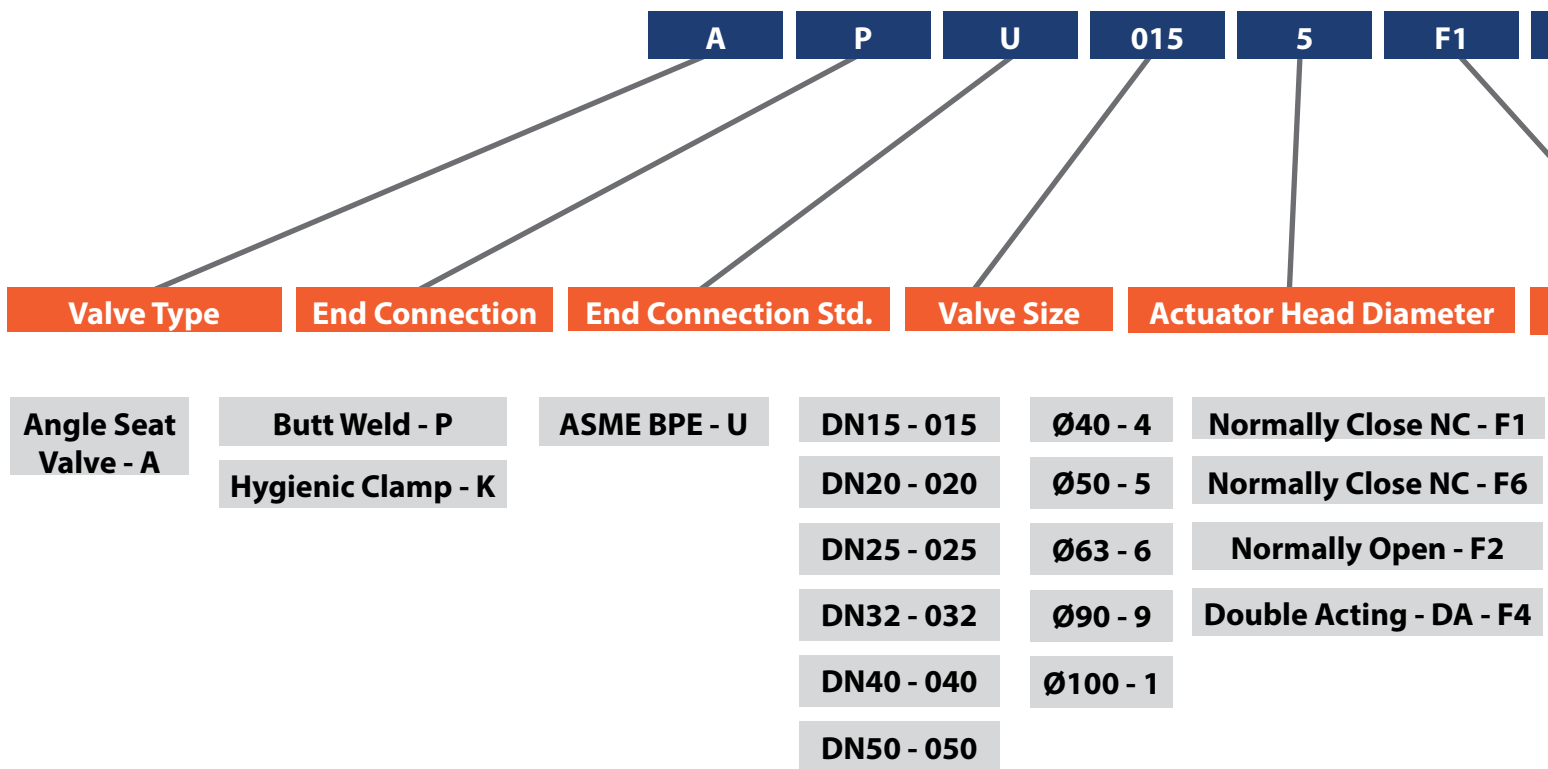

Coding
Single Acting Normally Closed F1/F6

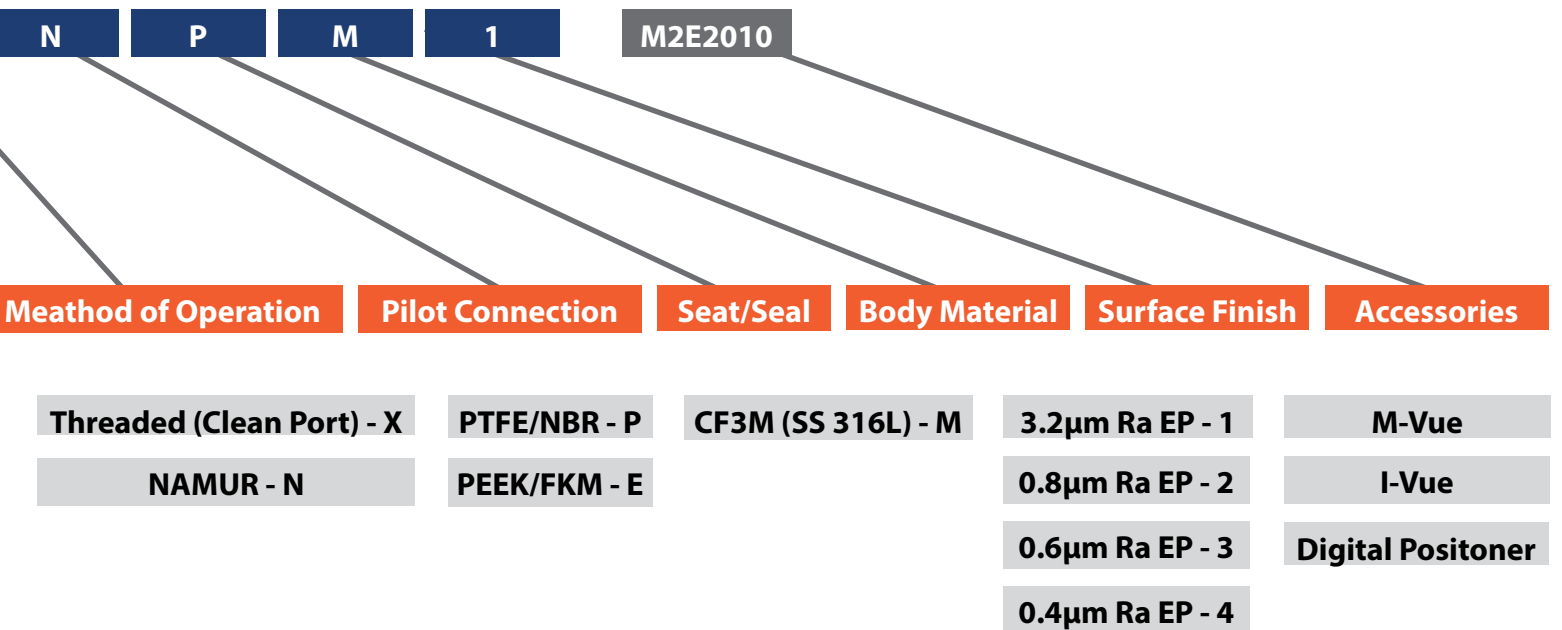

Standard Combinations

Single Acting Normally Closed F1/F6

Normally Closed – Standard Combinations

DN	OPERATOR	INLET
15	Ø50	Bi-Directional
20	Ø50	Bi-Directional
20	Ø50	Bi-Directional
25	Ø50	Bi-Directional
25	Ø63	Bi-Directional
40	Ø63	Bi-Directional
40	Ø63	Bi-Directional
40	Ø90	Bi-Directional
40	Ø90	Bi-Directional
50	Ø63	Above Plug
50	Ø90	Above Plug
50	Ø90	Bi-Directional
50	Ø110	Above Plug
50	Ø110	Bi-Directional

Operating/Performance Parameters

Single Acting Normally Open F2 Spring

Single Acting Normally Open F2 Spring

DN	Actuator \varnothing	Single acting Normally Open		
		Pressure below plug		
		Pilot Pressure	Fluid Pressure (bar)	
		Up to 10 bar	APU	AKU
15	50	3.4	0	0
		5	10	10
		7.1	25	16
20	50	2	0	0
		5	15	15
		7	25	16
25	50	2	0	0
		5	7.5	7.5
		10	21	12
25	63	2	0	0
		5	13	13
		7.5	25	16
40	63	3	0	0
		5	4.5	4.5
		10	17	10
40	90	2	0	0
		5	13	13
		7.5	25	16
50	90	2	0	0
		5	7	7
		10	20	12
50	110	1.4	0	0
		5	14	14
		7.5	25	16

Operating/Performance Parameters

Single Acting Normally Open F2 Spring

Single Acting Normally Open F2 Spring

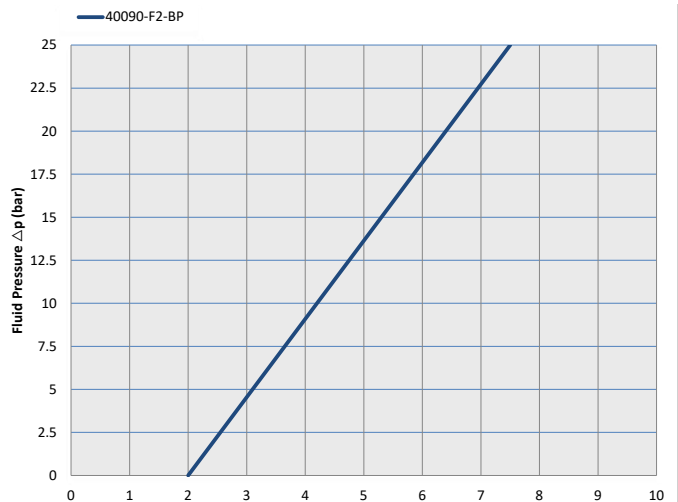
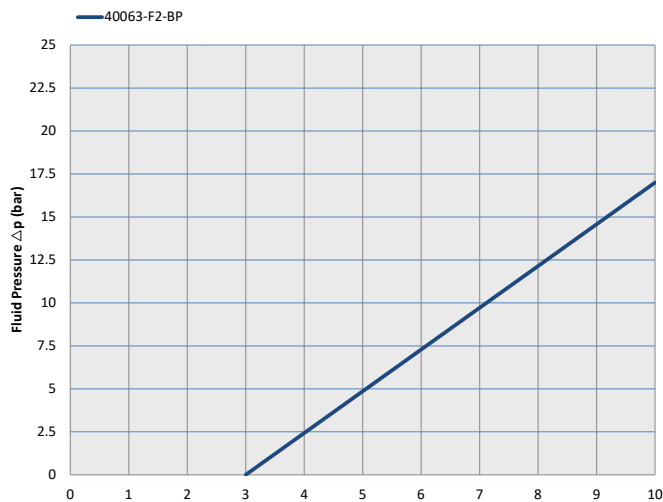
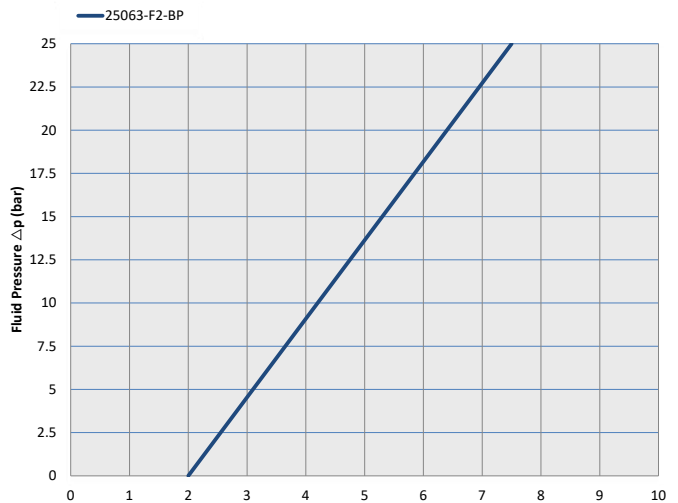
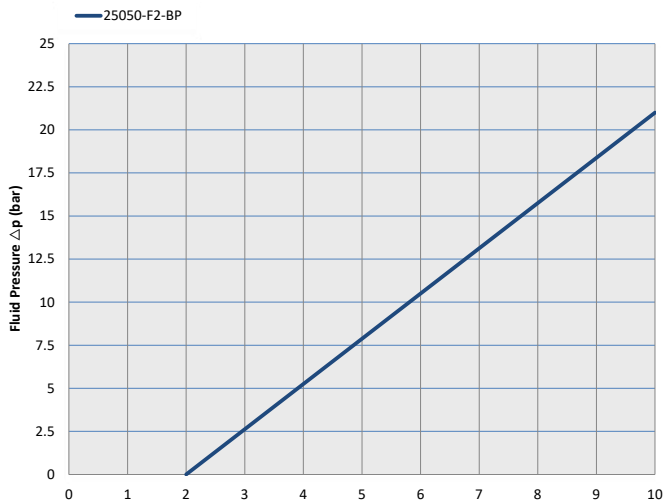
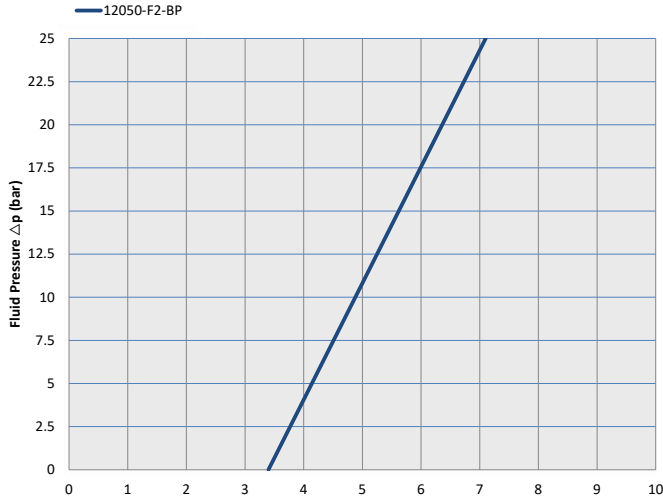

Operating/Performance Parameters

Single Acting Normally Open F2 Spring

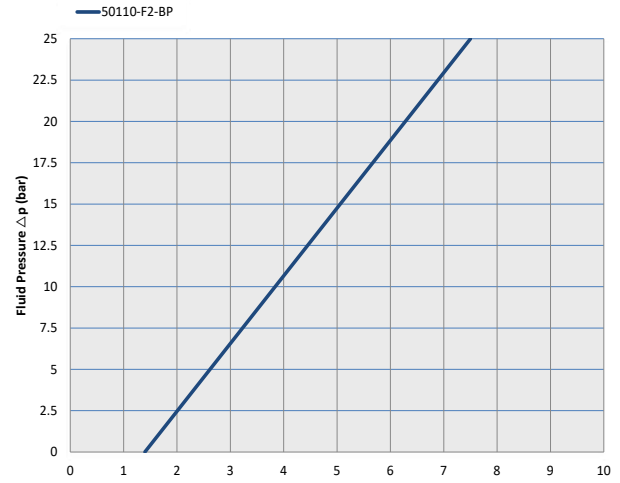
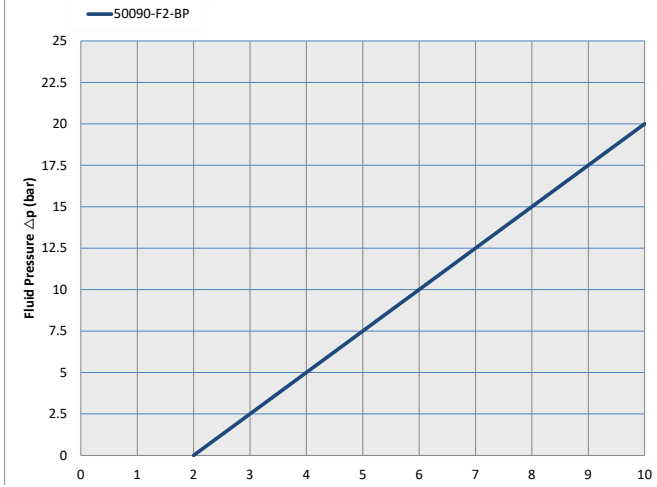

Operating/Performance Parameters

Single Acting Normally Open F4 Spring

Double Acting F4 Spring

DN	Actuator Ø	Double Acting, Bi-Directional					
		Pressure above plug			Pressure below plug		
		Pilot Pressure	Fluid Pressure (bar)		Pilot Pressure	Fluid Pressure (bar)	
		Up to 10 bar	APU	AKU	Up to 10 bar	APU	AKU
15	50	1.2	0	0	1.2	0	0
		2	16	16	3.4	16	16
		2.5	25				
20	50	1.8	0	0	1.8	0	0
		3.2	16	16	4.6	16	16
		4	25				
25	50	1.8	0	0	1.8	0	0
		4.4	16	16	5	11.5	11.5
		5.8	25		6	16	16
40	63	2	0	0	2	0	0
		5	12	12	5	8.5	8.5
		7.9	25	16	6	12	12
40	90	0.8	0	0	0.8	0	0
		3.8	16	16	4.6	16	16
		5.5	25				
50	90	1.4	0	0	1.4	0	0
		5	12.5	12.5	5	10.5	10.5
		8.3	25	16	6.5	16	16
50	110	1.1	0	0	1.1	0	0
		3.8	16	16	4.5	16	16

Note: 1. For PED certified valves, maximum fluid pressure is limited to minimum value specified in pressure/temperature chart on page 7 or table above

Double Acting F4

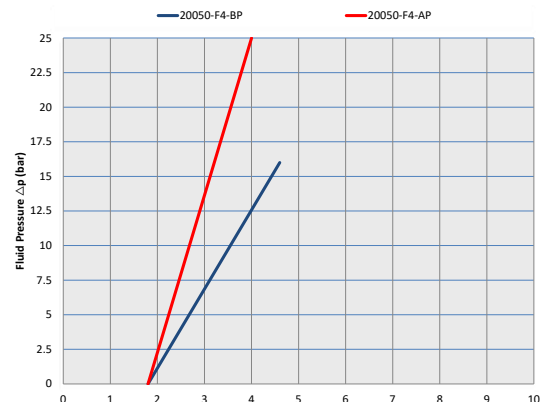
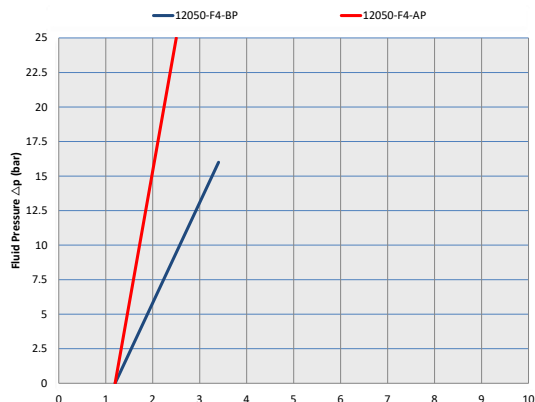

Operating/Performance Parameters

Single Acting Normally Open F4 Spring

Double Acting F4

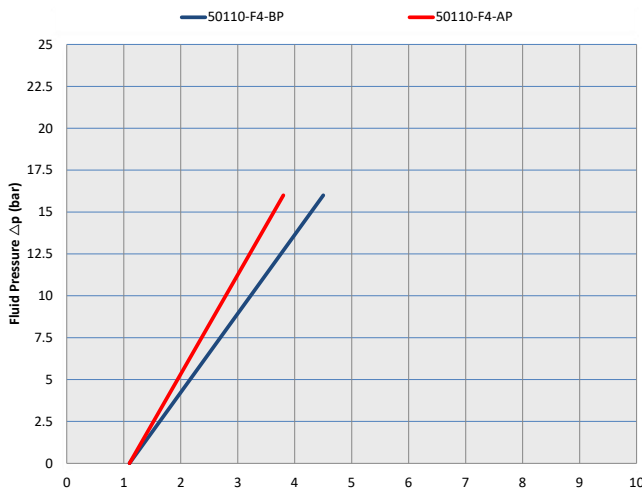
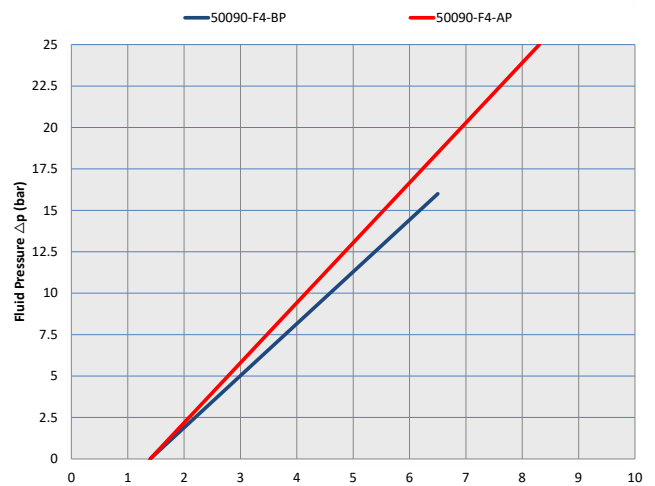
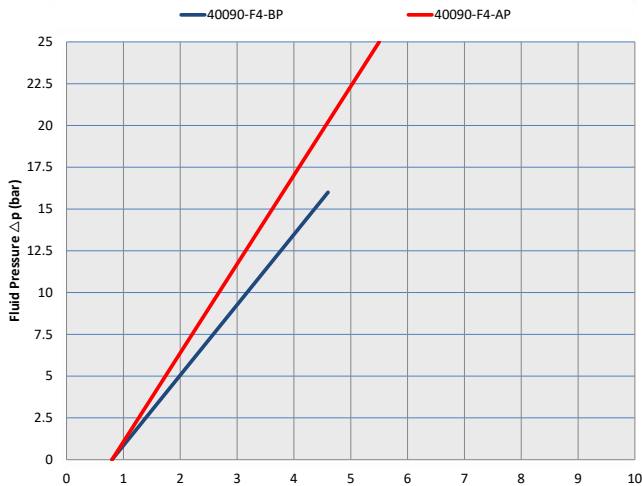
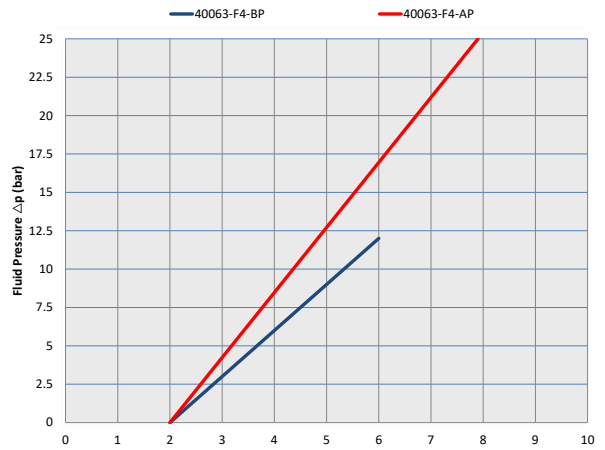
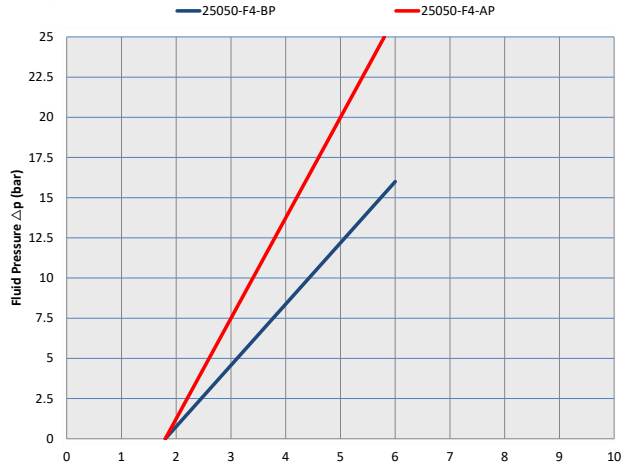

Product Coding - Accessories

VUE Sensors

M-Vue

-- M 2E2 0 1 0

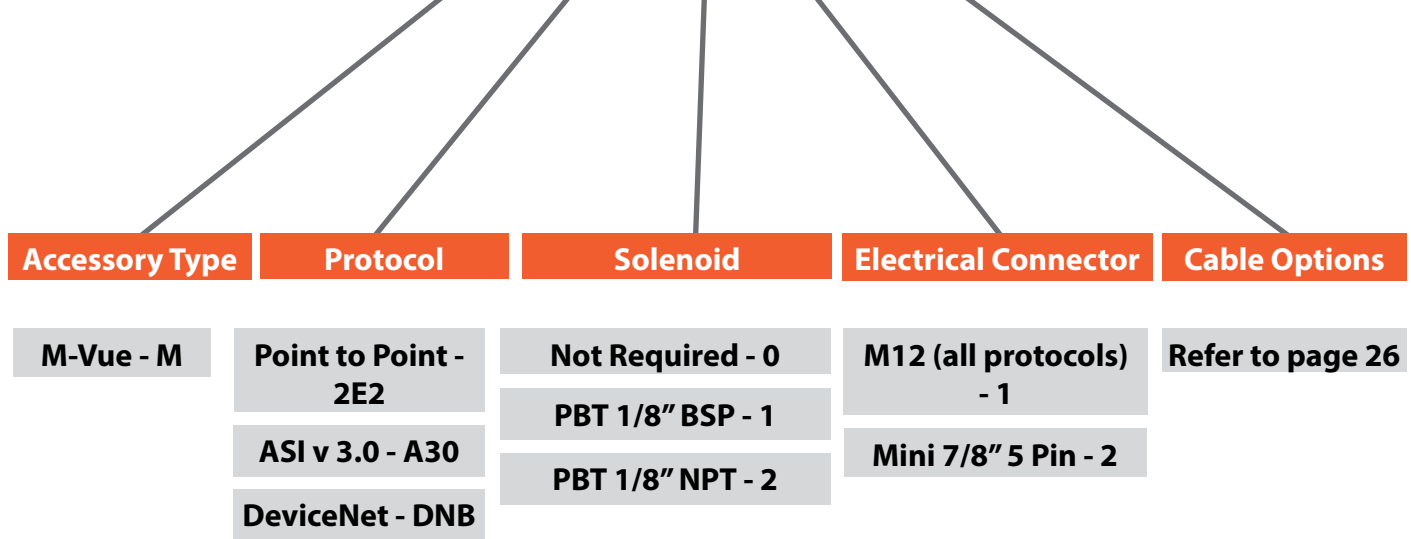

I-Vue

-- I 2E2 0 1 0

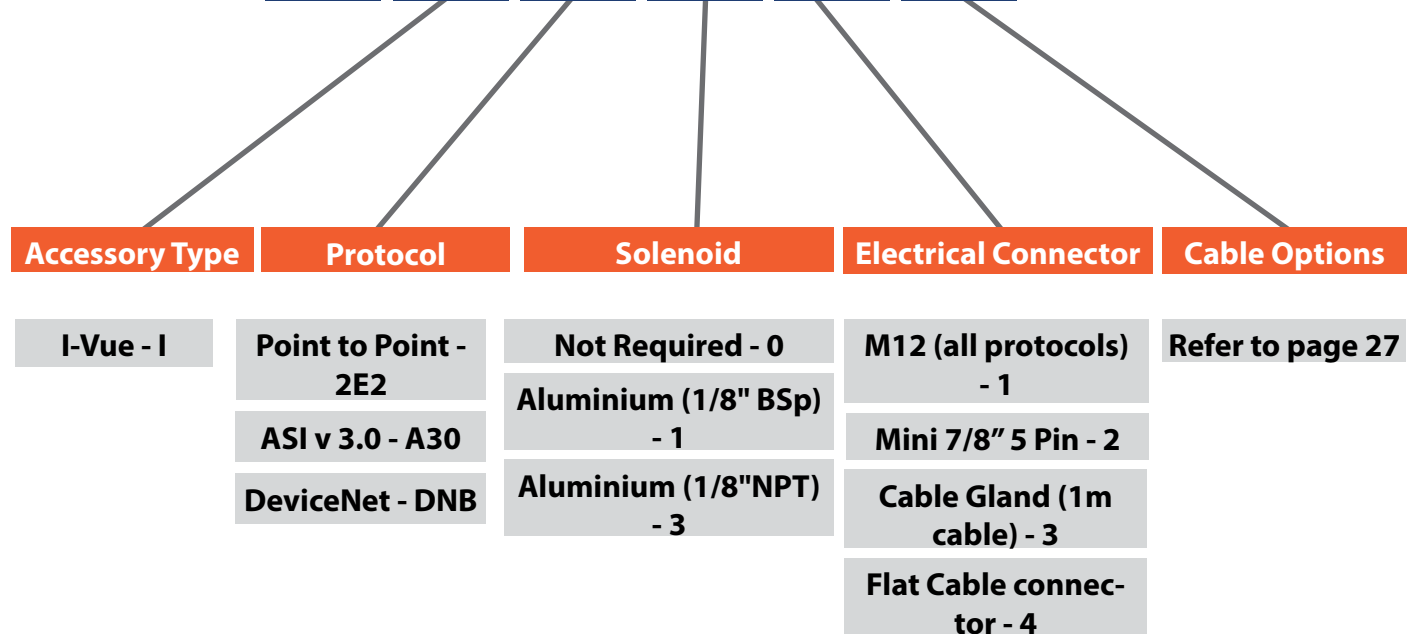

Product Coding - Accessories

Intelligent Positioners

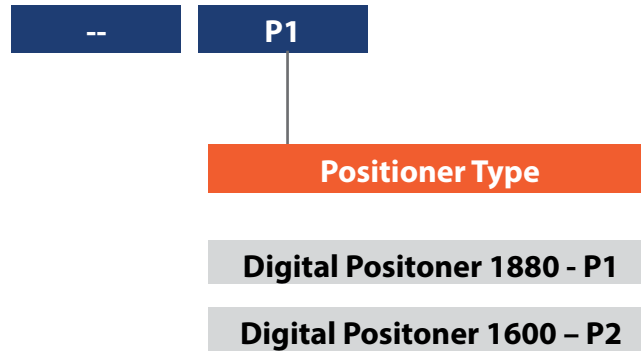



CRANE CHEMPHARMA & ENERGY

Crane Process Flow Technologies Ltd.
Grange Road
Cwmbran, Gwent
NP44 3XX, United Kingdom
Tel.: + 44 1633 486666

Crane Co., and its subsidiaries cannot accept responsibility for possible errors in catalogues, brochures, other printed materials, and website information. Crane Co. reserves the right to alter its products without notice, including products already on order provided that such alteration can be made without changes being necessary in specifications already agreed. All trademarks in this material are the property of the Crane Co. or its subsidiaries. The Crane and Crane brands logotype (CENTER LINE®, COMPAC-NOZ®, CRANE®, DEPA® & ELRO®, DOPAK®, DUO-CHEK®, FLOWSEAL®, GYROLOK®, GO REGULATOR®, HOKE®, JENKINS®, KROMBACH®, NOZ-CHEK®, PACIFIC VALVES®, RESISTOFLEX®, REVO®, SAUNDERS®, STOCKHAM®, TEXAS SAMPLING®, TRIANGLE®, UNI-CHEK®, VALVES®, WESTLOCK CONTROLS®, WTA®, and XOMOX®) are registered trademarks of Crane Co. All rights reserved.