

Saunders[®] 2-Way Forgings Optimum Drain Angles

www.cranecpe.com

Saunders[®] 2-way bodies fully drain in the horizontal orientation when installed at proper drain angle.

When positioned in the self drain angle, the low points of the tube bore, D-Ports, and weir are in the same plane, allowing fluid to drain out of the valve body.

To facilitate proper installation, Saunders[®] 2-way bodies are marked with drain angle on tube bore. When the marking is located at the 12 o'clock position, the body is at its drain angle.

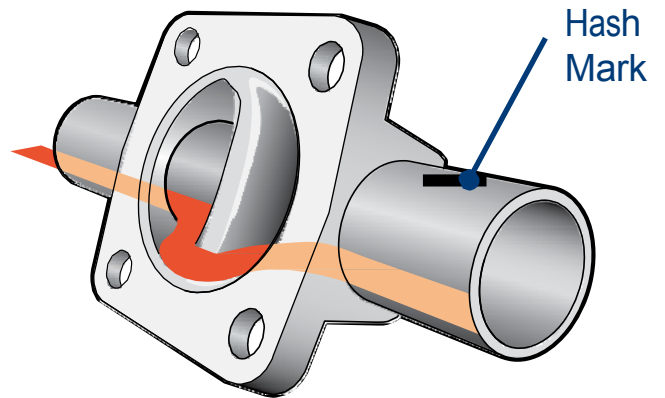

Under Rotated – Weir Acts as a Dam

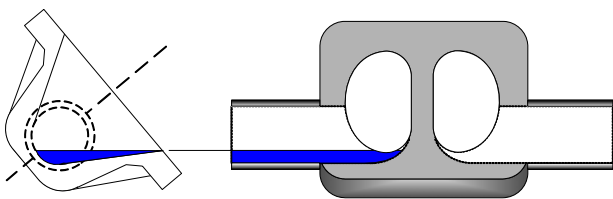

Over Rotated – Fluid Pools at Weir

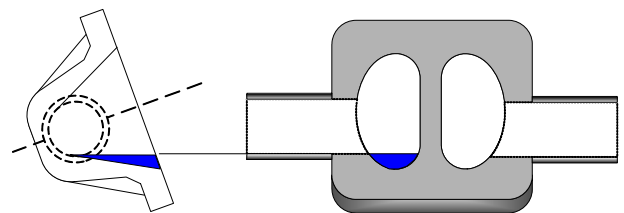

Saunders[®] 2-Way Forgings

Forged 2-Way Body Drain Angles Tube OD (ASME BPE)

Valve Size		Outside Diameter		Inside Diameter		Drain Angle Degrees
mm	in.	mm	in.	mm	in.	
DN8	0.25	6.35	0.25	3.05	0.12	35°
DN8 (DN10 end)	0.25 (0.375 end)	9.35	0.38	6.23	0.25	27°
DN8 (DN15 end)	0.25 (0.50 end)	12.7	0.5	9.4	0.37	19°
DN15	0.5	12.7	0.5	9.4	0.37	41°
DN20	0.75	19.05	0.75	15.75	0.62	32°
DN25	1	25.4	1	22.1	0.87	30°
DN40	1.5	38.1	1.5	34.8	1.37	25°
DN50	2	50.9	2	47.5	1.87	24°
DN65	2.5	63.5	2.5	60.2	2.37	19°
DN80	3	76.2	3	72.9	2.87	24°

Drain angle tolerance is +/- 2 degrees for optimum drainability.

Forged 2-Way Body Drain Angles DIN Tube

Valve Size (mm)	Outside Diameter (mm)	Inside Diameter (mm)	Drain Angle Degrees
DN8 (DN10 end)	13	10	20°
DN15 (DN10 end)	13	10	31°
DN15	19	16	25°
DN20	23	20	26°
DN25	29	26	17°
DN 40 (DN32 end)	35	32	27°
DN40	41	38	22°
DN50	53	50	20°
DN65	70	66	18°
DN80	85	81	21°

Sizes DN8-50 DIN Series 2

Sizes DN65-80 DIN Series 1

Drain angle tolerance is +/- 2 degrees for optimum drainability

Forged 2-Way Body Drain Angles ISO Tube

Valve Size (mm)	Outside Diameter (mm)	Inside Diameter (mm)	Drain Angle Degrees
DN8	13.5	10.3	20°
DN15 (DN10 end)	17.2	14	25°
DN15	21.3	18.1	19°
DN20	26.9	23.7	21°
DN25	33.7	29.7	12°
DN 40 (DN32 end)	42.4	38.4	22°
DN40	48.3	44.3	17°
DN50	60.3	55.1	16°
DN65	76.1	70.9	14°
DN80	88.9	83.7	20°

Drain angle tolerance is +/- 2 degrees for optimum drainability.

The optimum drain angle varies by valve size and piping specification. Refer to specific data sheets for drain angles of other piping specifications including Tube OD and Schedule Pipe.

Saunders[®] full portfolio of drawing data can be accessed at www.saundersdrawings.com in both 2D and 3D file format for dimensions and drain angles of Saunders[®] BioPharm valves.

The slope of process piping must be designed to facilitate optimum drainability.

Drainability in a process system is the responsibility of the system designer and end user.

9860 Johnson Rd
Montgomery, TX 77316
Phone: +1 936 588 8360
Fax: +1 936 588 8302
www.cranecpe.com

Crane ChemPharma & Energy, SAUNDERS[®]

Crane Co., and its subsidiaries cannot accept responsibility for possible errors in catalogues, brochures, other printed materials, and website information. Crane Co. reserves the right to alter its products without notice, including products already on order provided that such alteration can be made without changes being necessary in specifications already agreed. All trademarks in this material are property of the Crane Co. or its subsidiaries. The Crane and Crane brands logotype, in alphabetical order, (ALOYCO[®], CENTER LINE[®], COMPAC-NOZ[®], CRANE[®], DEPA[®], DUO-CHEK[®], ELRO[®], FLOWSEAL[®], JENKINS[®], KROMBACH[®], NOZ-CHEK[®], PACIFIC VALVES[®], RESISTOFLEX[®], REVO[®], SAUNDERS[®], STOCKHAM[®], TRIANGLE[®], UNI-CHEK[®], WTA[®], and XOMOX[®]) are registered trademarks of Crane Co. All rights reserved.