



PACIFIC VALVES

brands you trust.

TECHNICAL DATASHEET
PACIFIC VALVES® - Pressure Seal Valves

CRANE®

www.cranecpe.com



Index

Index

Materials of Construction, Gate Valves	3
Gate Valve Product Line	4-7
Materials of Construction, Globe Valves	8
Globe Valve Product Line	9-11
Materials of Construction, Lift-Check Valves	12
Lift-Check Valve Product Line	13-15
Materials of Construction, Y-Globe Valves	16
Y-Globe Stop and Stop-Check Valve Product Line	17-20
Materials of Construction, Y-Globe Lift-Check Valves	21
Y-Globe Lift-Check Valve Product Line	22-25
Materials of Construction, Tilting Disc Check Valves	26
Tilting Disc Check Valve Product Line	27-29
Swing Check Valve Dimensions and Weight	30
Materials of Construction, Swing Check Valves	31
Figure Number System	32



Materials Gate Valves

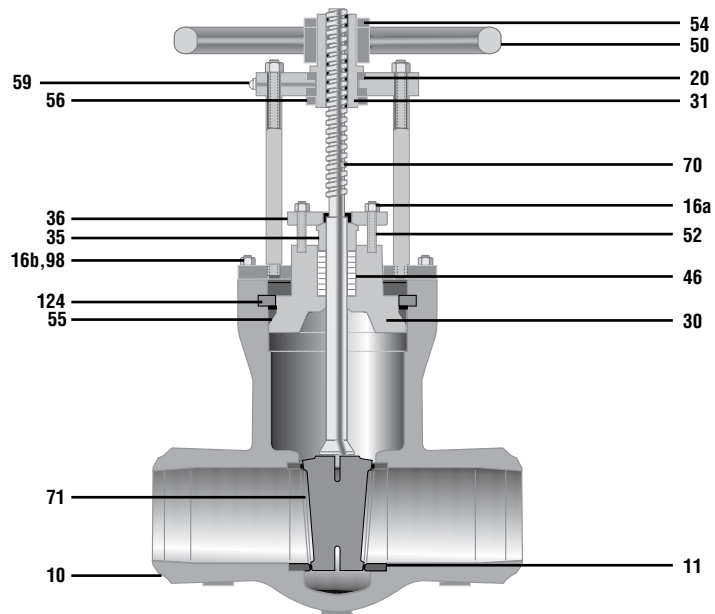

NO	PART NAME	CARBON STEEL	1 1/4 CHROME	2 1/4 CHROME	9Cr-1Mo-V	316 STAINLESS
50	HANDWHEEL	ASTM A47 GR 32510	ASTM A47 GR 32510	ASTM A47 GR 32510	ASTM A47 GR 32510	ASTM A47 GR 32510
31	YOKE SLEEVE	ASTM A148 ALLOY 955	ASTM A148 ALLOY 955	ASTM A148 ALLOY 955	ASTM A148 ALLOY 955	ASTM A148 ALLOY 955
20	BEARINGS	MFG STD	MFG STD	MFG STD	MFG STD	MFG STD
52	GLAND STUD	CARBON STEEL	CARBON STEEL	CARBON STEEL	CARBON STEEL	CARBON STEEL
16a	NUTS	ASTM A194 GR 2H	ASTM A194 GR 2H	ASTM A194 GR 2H	ASTM A194 GR 2H	ASTM A194 GR 2H
36	GLAND FLANGE	CARBON STEEL	CARBON STEEL	CARBON STEEL	CARBON STEEL	CARBON STEEL
35	GLAND	12% CHROME	12% CHROME	12% CHROME	12% CHROME	300 SERIES SST
46	PACKING	GRAPHITIC*	GRAPHITIC**	GRAPHITIC**	GRAPHITIC**	GRAPHITIC**
124	SEGMENT RING	AISI 4140 OR 4340	AISI 4140 OR 4340	AISI 4140 OR 4340	AISI 4140 OR 4340	AISI 4140 OR 4340
73	THRUST RING ⁴	AISI 4340 OR 4140	AISI 4340 OR 4140	AISI 4340 OR 4140	AISI 4340 OR 4140	AISI 4340 OR 4140
55	GASKET	GRAPHITE/SS CAPS OR MILD STEEL SILVER PLATED***	GRAPHITE/SS CAPS OR MILD STEEL SILVER PLATED***	GRAPHITE/SS CAPS OR MILD STEEL SILVER PLATED***	GRAPHITE/SS CAPS OR MILD STEEL SILVER PLATED***	GRAPHITE/SS CAPS OR MILD STEEL SILVER PLATED***
30	BONNET	CARBON STEEL W/CO-CR	ASTM A182 GR F22 W/CO-CR	ASTM A182 GR F22 W/CO-CR	ASTM A182 GR F91 W/CO-CR	ASTM A182 GR F316 W/CO-CR
70	STEM	13% CHROME	13% CHROME	13% CHROME	13% CHROME	ASTM A705 GR 630
10	BODY ¹	ASTM A216 GR WCB/WCC ³	ASTM A217 GR WC6	ASTM A217 GR WC9	ASTM A217 GR C12A	ASTM A351 GR CF8M
71	WEDGE DISC	CARBON STEEL W/CO-CR OVERLAY	316 / 316L OR 2 1/4 CR W/CO-CR OVERLAY	316L SS OR 2 1/4 CR W/CO-CR OVERLAY	316L SS W/CO-CR OVERLAY	ASTM A351 GR CF8M W/CO-CR OVERLAY
11	SEAT RINGS	CARBON STEEL W/CO-CR OVERLAY	316 / 316L OR 2 1/4 CR W/CO-CR OVERLAY	316L SS OR 2 1/4 CR W/CO-CR OVERLAY	ALLOY 91 W/CO-CR OVERLAY	316L SS W/CO-CR OVERLAY
98	BONNET STUDS	ASTM A193 GR B7	ASTM A193 GR B7	ASTM A193 GR B7	ASTM A193 GR B7	ASTM A193 GR B7
16b	STUD NUTS	ASTM A194 GR 2H	ASTM A194 GR 2H	ASTM A194 GR 2H	ASTM A194 GR 2H	ASTM A194 GR 2H
25	CARRIER ²	CARBON STEEL	F11	F22	SST	316 SS
26	PIN ²	12% CR	12% CR	12% CR	12% CR	17-4 PH
27	SPRING ²	INCONEL	INCONEL	INCONEL	INCONEL	INCONEL
56	JAM NUT	CARBON STEEL	CARBON STEEL	CARBON STEEL	CARBON STEEL	CARBON STEEL
30	PIN ²	12% CR	12% CR	12% CR	12% CR	17-4 PH
16c	NUTS	ASTM A194 GR 2H	ASTM A194 GR 2H	ASTM A194 GR 2H	ASTM A194 GR 2H	ASTM A194 GR 2H
59	GREASE FITTING	MFG. STD.	MFG. STD.	MFG. STD.	MFG. STD.	MFG. STD.
98	THREADED COL.	ASTM A193 GR B7	ASTM A193 GR B7	ASTM A193 GR B7	ASTM A193 GR B7	ASTM A193 GR B7
98a	BOLTING	ASTM A193 GR B7	ASTM A193 GR B7	ASTM A193 GR B7	ASTM A193 GR B7	ASTM A193 GR B7
98b	DRAW BOLTING	ASTM A193 GR B7	ASTM A193 GR B7	ASTM A193 GR B7	ASTM A193 GR B7	ASTM A193 GR B7
54	HANDWHEEL NUT	CARBON STEEL	CARBON STEEL	CARBON STEEL	CARBON STEEL	CARBON STEEL
128	TUBULAR COL.	CARBON STEEL	CARBON STEEL	CARBON STEEL	CARBON STEEL	CARBON STEEL

Pacific Valves® reserves the right to change or modify product design or construction without prior notice and without incurring any obligation to make such changes and modifications on products previously or subsequently sold.

NOTES:

1. A 309 SS inlay is standard in the gasket area of the body on ASME class 2500 valves. For this option on other pressure classes, specify special features suffix H.
2. Parallel Disc only.
3. WCC valve bonnets and internals will be manufactured with 300 series SS and/or 2 1/4 CR.
4. Thrust ring comes standard on 12" and larger ASME class 1500 and all sizes of ASME class 2500.

*Special high temperature packing is recommended for services over 850°F. Consult factory when ordering.

**High temperature packing is standard.

***Graphite Pressure Seal Bonnet Gasket standard. Mild Steel Silver Plated available on request.



Dimensions Gate Valves • ASME Class 600

Fig. No. **55506-7-WE*** Flex Wedge, Butt Weld Ends
 Fig. No. **55506-7** Flex Wedge, Flanged Raised Face
 Fig. No. **55506-7-RJ** Flex Wedge, Flanged, Ring Joint

Fig. No. **55406-7-WE*** Parallel Seat Disc, Butt Weld Ends
 Fig. No. **55406-7** Parallel Seat Disc, Flanged, Raised Face
 Fig. No. **55406-7-RJ** Parallel Seat Disc, Flanged, Ring Joint

Dim	Description		VALVE SIZES (inches)										
			2	2.5	3	4	6	8	10	12	18	20	24
A	End-to-End Weld Ends	in.	8.50	8.50	10.00	12.00	18.00	23.00	28.00	32.00	43.00	47	55.00
		mm	216	216	254	305	458	585	712	813	1092	1194	1397
A ₁	Face-to-Face Flanged Ends	in.	N/A	N/A	14.00	17.00	22.00	26.00	31.00	33.00	43.00	47	55.00
		mm	N/A	N/A	356	432	559	661	788	839	1092	1194	1397
A ₂	Face-to-Face RTJ	in.	N/A	N/A	14.13	17.13	22.13	26.13	31.33	33.13	43.13	47.13	55.38
		mm	N/A	N/A	359	436	563	664	791	842	1096	1197	1407
K	Center-to-Top Open	in.	18.06	18.06	18.69	22.81	32.69	38.00	45.56	51.19	76.00	80.00	94.00
		mm	485	485	475	580	831	966	1158	1301	1930	2032	2388
M	Handwheel Dia.	in.	14	14	14	14	14	18	24	24	24	24	24
		mm	356	356	356	254	356	457	610	610	610	610	610
*	Weight Weld Ends	lbs.	78	78	80	123	312	588	995	1462	4000	5200	8300
		kg	36	36	37	56	141	265	448	658	1814	2359	3765
	Weight Flanged Ends	lbs.	125	125	131	213	511	903	1495	2157	4750	5900	9570
		kg	57	57	59	96	230	407	673	971	2155	2676	4340

NOTE:
 1. Valves are supplied with a handwheel actuator on all sizes.

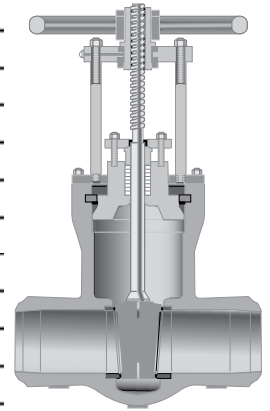

VENTURI GATE VALVES Fig. No. 55506-7-WE* Butt Weld Ends

Dim	Description		VALVE SIZES (inches)						
			8x6x8	10x8x10	12x10x12	14x12x14	20x18x20	24x20x24	26x24x26
A	End-to-End	in.	18	23	28	32	43.00	47	55.00
		mm	458	585	712	813	1092	1194	1397
K	Center-to-Top Open	in.	32.69	38.00	45.56	51.19	76.00	80	94.00
		mm	831	966	1158	1301	1930	2032	2388
M	Handwheel Dia.	in.	14	18	24	24	24	24	24
		mm	356	457	610	610	610	610	610
	Weight	lbs.	359	682	1124	1550	4200	6100	8700
		kg	163	309	510	703	1905	2767	3946

NOTES:
 1. Valves are supplied with a handwheel actuator on all sizes.

General Notes:

- Dimensions, weights, and other engineering data are subject to change or modification. This data is not to be used for construction unless confirmed by Pacific Valves®.
- All pressure seal gate valves are available with a solid wedge. Specify figure number 55006.
 * Specify pipe schedule.
- Related data available in Technical Data, Actuators, and Accessories sections.

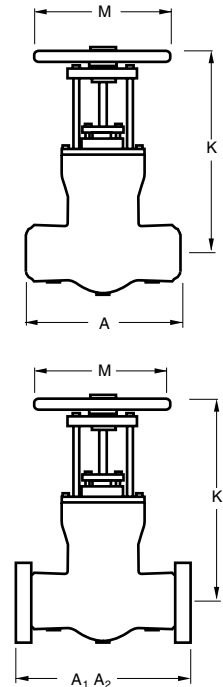



Dimensions Gate Valves • ASME Class 900

Fig. No. **55509-7-WE*** Flex Wedge, Butt Weld Ends
 Fig. No. **55509-7** Flex Wedge, Flanged Raised Face
 Fig. No. **55509-7-RJ** Flex Wedge, Flanged, Ring Joint

Fig. No. **55409-7-WE*** Parallel Seat Disc, Butt Weld Ends
 Fig. No. **55409-7** Parallel Seat Disc, Flanged, Raised Face
 Fig. No. **55409-7-RJ** Parallel Seat Disc, Flanged, Ring Joint

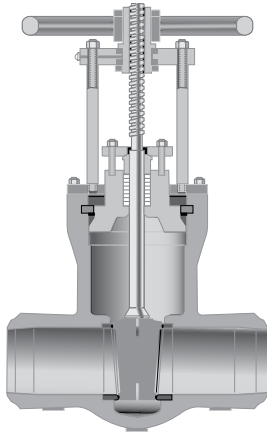

Dim	Description	VALVE SIZES (inches)													
		2	2.5	3	4	6	8	10	12	14	16	18	20	24	
A	End-to-End Weld Ends	in.	8.5	10	12	14	20	26	31	36	39	43	48	52	61
		mm	216	254	305	356	508	660	787	914	991	1092	1219	1321	1549
A ₁	Face-to-Face Flanged Ends	in.	N/A	N/A	15	18	24	29	33	38	40.5	44.5	48	52	61
		mm	N/A	N/A	381	457	609	736	838	965	1028	1130	1219	1320	1549
A ₂	Face-to-Face RTJ	in.	N/A	N/A	15.13	18.13	24.13	29.13	33.13	38.13	40.88	44.88	48.5	52.5	61.75
		mm	N/A	N/A	384	460	612	740	841	968	1039	1140	1231	1333	1568
K	Center-to-Top Open	in.	17.25	17.25	19.06	22.44	32.25	37.31	45.13	51.06	59.00	69.00	75.00	81.00	91.00
		mm	438	438	485	570	820	948	1147	1297	1499	1758	1911	2044	2311
M	Handwheel Dia.	in.	14	14	14	14	18	24	28	34	34	30	30	30	20
		mm	356	356	356	254	457	609	711	863	863	762	762	762	508
**	Weight Weld Ends	lbs	63	63	84	129	328	619	1048	1539	2177	3066	4600	5369	8603
		kg	29	29	38	59	148	279	472	693	987	1390	2086	2434	3901
**	Weight Flanged Ends	lbs	N/A	N/A	137	224	537	930	1559	2250	3180	4300	6400	7500	12600
		kg	N/A	N/A	62	101	243	419	702	1013	1442	1950	2902	3401	5714

NOTE:

1. Valves are supplied with a handwheel actuator through 14". Bevel gear supplied on 16"-24".

VENTURI GATE VALVES Fig. No. 55509-7-WE* Butt Weld Ends

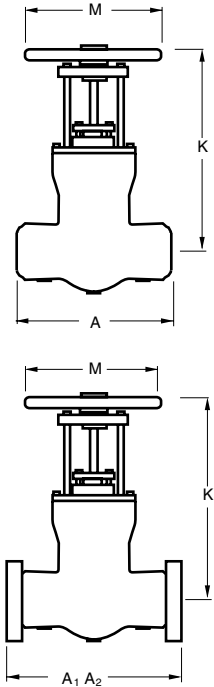

Dim	Description	VALVE SIZES (inches)									
		8x6x8	10x8x10	12x10x12	14x12x14	16x14x16	18x16x18	20x18x20	22x20x22	26x24x26	
A	End-to-End	in.	20	26	31	36	39	43	48	52	61
		mm	508	660	787	914	991	1092	1219	1321	1549
K	Center-to-Top Open	in.	32.25	37.31	45.13	51.06	59	69	75	81	91
		mm	820	948	1147	1297	1499	1651	1778	2044	2311
M	Handwheel Dia.	in.	18	24	28	34	34	30	30	30	20
		mm	457	609	711	863	863	762	762	762	508
**	Weight	lbs	340	642	1083	1586	2238	3140	4700	5500	8750
		kg	153	289	488	714	1008	1413	2115	2475	3938

NOTES:

1. Valves are supplied with a handwheel actuator through 16" x 14" x 16". Bevel gear supplied on 18" x 16" x 18" and larger.

General Notes:

- Dimensions, weights, and other engineering data are subject to change or modification. This data is not to be used for construction unless confirmed by Pacific Valves®.
- All pressure seal gate valves are available with a solid wedge. Specify figure number 55009.
* Specify pipe schedule.
**Weight includes standard bevel gear where applicable (see note 1 above).
- Related data available in Technical Data, Actuators, and Accessories sections.



Dimensions Gate Valves • ASME Class 1500

Fig. No. **55515-7-WE*** Flex Wedge, Butt Weld Ends
 Fig. No. **55515-7** Flex Wedge, Flanged Raised Face
 Fig. No. **55515-7-RJ** Flex Wedge, Flanged, Ring Joint

Fig. No. **55415-7-WE*** Parallel Seat Disc, Butt Weld Ends
 Fig. No. **55415-7** Parallel Seat Disc, Flanged, Raised Face
 Fig. No. **55415-7-RJ** Parallel Seat Disc, Flanged, Ring Joint

Dim	Description	VALVE SIZES (inches)													
		2	2.5	3	4	6	8	10	12	14	16	18	20	24	
A	End-to-End Weld Ends	in.	8.5	10	12	16	22	28	34	39	42	47	53	58	60
		mm	216	254	305	406	559	711	864	991	1067	1194	1346	1473	1943
A ₁	Face-to-Face Flanged Ends	in.	16.5	16.5	18.5	21.5	27.75	32.75	39	44.5	49.5	54.5	60.5	65.5	76.5
		mm	419	419	470	546	705	831	990	1130	1257	1384	1536	1663	1943
A ₂	Face-to-Face RTJ	in.	16.63	16.63	18.63	21.63	28	33.13	39.38	45.13	50.25	55.38	61.38	66.38	77.63
		mm	422	422	473	549	711	841	1000	1146	1276	1406	1559	1685	1972
K	Center-to-Top Open	in.	17.25	17.25	21.00	24.75	33.00	36.75	44.50	50.63	67	74	77	90	98
		mm	438	438	533	629	837	933	1130	1286	1695	1880	1962	2286	2489
M	Handwheel Dia.	in.	14	14	14	14	24	24	24	24	30	30	30	30	30
		mm	356	356	356	254	610	610	610	610	762	762	762	762	762
**	Weight Weld Ends	lbs	63	63	110	200	524	905	1880	2536	3226	4211	5453	6322	9450
		kg	29	29	50	90	236	408	846	1142	1452	1909	2454	2867	4286
**	Weight Flanged Ends	lbs	130	130	181	322	751	1330	2242	3610	4954	6516	8520	10157	14175
		kg	59	59	82	145	338	599	1009	1625	2246	2955	3863	4606	6430

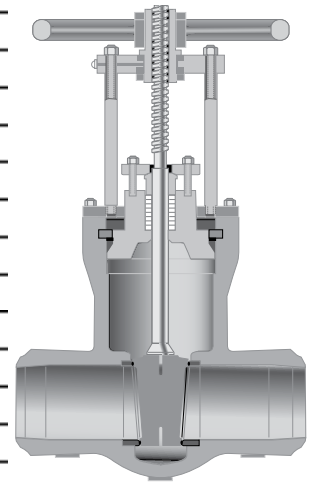

NOTE:
 1. Valves are supplied with a handwheel actuator through 12". Bevel gear supplied on 14"-24".

VENTURI GATE VALVES Fig. No. 55515-7-WE* Butt Weld Ends

Dim	Description	VALVE SIZES (inches)								
		8x6x8	10x8x10	12x10x12	14x12x14	16x14x16	18x16x18	20x18x20	22x20x22	
A	End-to-End	in.	22	28	34	39	42	47	53	58
		mm	559	711	864	991	1067	1194	1346	1473
K	Center-to-Top Open	in.	33	36.75	44.50	50.63	67	74	77	90
		mm	837	933	1130	1286	1689	1880	1962	2286
M	Handwheel Dia.	in.	24	34	34	34	30	20	20	20
		mm	609	863	863	863	762	508	508	508
**	Weight	lbs	545	938	1943	2615	3316	4316	5573	6500
		kg	246	423	875	1177	1493	1943	2508	2948

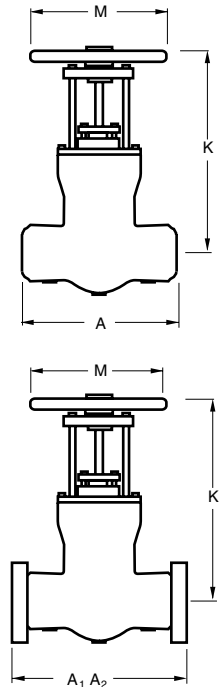

NOTES:
 1. Valves are supplied with a handwheel actuator through 14" x 12" x 14". Bevel gear supplied on 16" x 14" x 16" and larger.

- General Notes:**
- Dimensions, weights, and other engineering data are subject to change or modification. This data is not to be used for construction unless confirmed by Pacific Valves®.
 - All pressure seal gate valves are available with a solid wedge. Specify figure number 55015.
 * Specify pipe schedule.
 **Weight includes standard bevel gear where applicable (see note 1 above).
 - Related data available in Technical Data, Actuators, and Accessories sections.



Dimensions Gate Valves • ASME Class 2500

Fig. No. **55525H-7-WE*** Flex Wedge, Butt Weld Ends
 Fig. No. **55525H-7** Flex Wedge, Flanged Raised Face
 Fig. No. **55525H-7-RJ** Flex Wedge, Flanged, Ring Joint

Fig. No. **55425H-7-WE*** Parallel Seat Disc, Butt Weld Ends
 Fig. No. **55425H-7** Parallel Seat Disc, Flanged, Raised Face
 Fig. No. **55425H-7-RJ** Parallel Seat Disc, Flanged, Ring Joint

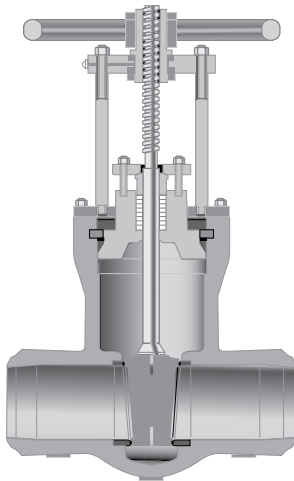

Dim	Description		VALVE SIZES (inches)												
			2	2.5	3	4	6	8	10	12	14	16	18	20	24
A	End-to-End Weld Ends	in.	14.5	13	14.5	18	24	30	36	41	44	49	55	62	66
		mm	368	330	368	457	609	762	914	1041	1117	1244	1397	1574	1676
A ₁	Face-to-Face Flanged Ends	in.	22.75	22.75	22.75	26.5	36	40.25	50	56	(2)	(2)	(2)	(2)	(2)
		mm	577	577	577	673	914	1028	1270	1422	(2)	(2)	(2)	(2)	(2)
A ₂	Face-to-Face RTJ	in.	23	23	23	26.88	36.5	40.88	50.88	56.88	(2)	(2)	(2)	(2)	(2)
		mm	584	584	584	683	957	1039	1293	1445	(2)	(2)	(2)	(2)	(2)
K	Center-to-Top Open	in.	22.00	22.00	22.00	25.88	32.50	37.50	40.75	56.00	72	81	89	97	115
		mm	559	559	559	658	826	953	1036	1423	1829	2057	2260	2464	2921
M	Handwheel Dia.	in.	14	14	14	18	24	24	24	30	30	30	30	30	30
		mm	356	356	254	457	610	610	610	762	762	762	762	762	762
**	Weight Weld Ends	lbs	268	268	268	304	805	1205	2113	3053	4107	5482	7653	10162	15900
		kg	121	121	121	137	363	543	951	1374	1862	2486	3470	4608	7210
**	Weight Flanged Ends	lbs	428	428	428	532	1425	2090	4038	5890	(2)	(2)	(2)	(2)	(2)
		kg	193	193	193	240	642	941	1818	2651	(2)	(2)	(2)	(2)	(2)

NOTES:

- Valves are supplied with a handwheel actuator on sizes 2½" - 10". Bevel gear supplied on 12" - 24".
- For flanged end data on 14" - 24"— contact Pacific Valves®.

VENTURI GATE VALVES Fig. No. 55525H-7-WE* Butt Weld Ends

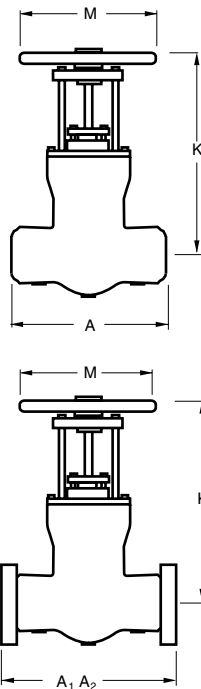

Dim	Description		VALVE SIZES (inches)						
			8x6x8	10x8x10	12x10x12	14x12x14	16x14x16	18x16x18	20x18x20
A	End-to-End	in.	24	30	36	41	44	49	55
		mm	610	762	914	1041	1118	1245	1397
K	Center-to-Top Open	in.	32.50	37.50	40.75	56.00	72	81	89
		mm	826	953	1036	1423	1829	2057	2261
M	Handwheel Dia.	in.	24	34	34	30	20	20	24
		mm	609	863	863	762	508	508	609
**	Weight	lbs	837	1250	2185	3148	4222	5620	7760
		kg	377	563	984	1417	1900	2529	3527

NOTES:

- Valves are supplied with a handwheel actuator through 12". Bevel gear supplied on 14" x 12" x 24" and larger.

General Notes:

- Dimensions, weights, and other engineering data are subject to change or modification. This data is not to be used for construction unless confirmed by Pacific Valves®.
- All pressure seal gate valves are available with a solid wedge. Specify figure number 55025.
* Specify pipe schedule.
**Weight includes standard bevel gear where applicable (see note 1 above).
- Related data available in Technical Data, Actuators, and Accessories sections.



Materials Globe Stop & Stop-Check Valves

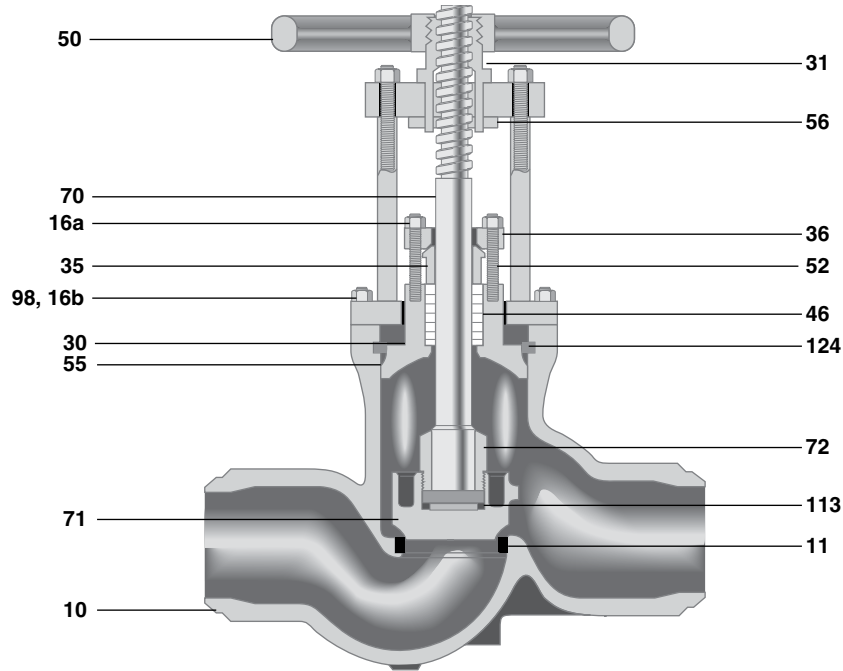

NO	PART NAME	CARBON STEEL	1¼ CHROME	2½ CHROME	9 Cr-1Mo-V	316 STAINLESS
50	HANDWHEEL	ASTM A47 GR 32510	ASTM A47 GR 32510	ASTM A47 GR 32510	ASTM A47 GR 32510	ASTM A47 GR 32510
31	YOKE SLEEVE	ASTM A148 ALLOY 955	ASTM A148 ALLOY 955	ASTM A148 ALLOY 955	ASTM A148 ALLOY 955	ASTM A148 ALLOY 955
20	BEARINGS	MFG STD	MFG STD	MFG STD	MFG STD	MFG STD
70	STEM	13% CHROME	13% CHROME	13% CHROME	13% CHROME	ASTM A705 GR 630
36	GLAND FLANGE	CARBON STEEL	CARBON STEEL	CARBON STEEL	CARBON STEEL	CARBON STEEL
35	GLAND	12% CHROME	12% CHROME	12% CHROME	12% CHROME	300 SERIES SST
46	PACKING	GRAPHITIC*	GRAPHITIC**	GRAPHITIC**	GRAPHITIC**	GRAPHITIC**
30	BONNET	CARBON STEEL	ASTM A182 GR, F22	ASTM A182 GR, F22	ASTM A182 GR, F91	ASTM A182 GR, F316
		W/CO-CR	W/CO-CR	W/CO-CR	W/CO-CR	W/CO-CR
124	SEGMENT RING	AISI 4340 OR 4140	AISI 4340 OR 4140	AISI 4340 OR 4140	AISI 4340 OR 4140	AISI 4340 OR 4140
73	THRUST RING ³	AISI 4340 OR 4140	AISI 4340 OR 4140	AISI 4340 OR 4140	AISI 4340 OR 4140	AISI 4340 OR 4140
55	GASKET	GRAPHITE/SS CAPS OR MILD STEEL SILVER PLATED***	GRAPHITE/SS CAPS OR MILD STEEL SILVER PLATED***	GRAPHITE/SS CAPS OR MILD STEEL SILVER PLATED***	GRAPHITE/SS CAPS OR MILD STEEL SILVER PLATED***	GRAPHITE/SS CAPS OR MILD STEEL SILVER PLATED***
72	DISC NUT	CARBON STEEL	316 SS OR 2¼ CR	316 SS OR 2¼ CR	316 SS	316L SS
71	DISC	CARBON STEEL	316 SS OR 2¼ CR	316 SS OR 2¼ CR	316 SS	316L SS
11	SEAT RING	CARBON STEEL W/CO-CR	316 SS OR 2¼ CR W/CO-CR	316 SS OR 2¼ CR W/CO-CR	ALLOY 91 W/CO-CR OVERLAY	316L SS
10	BODY ¹	ASTM A216 GR WCB OR WCC ²	ASTM A217 GR WC6	ASTM A217 GR WC9	ASTM A217 GR C12-A	ASTM A351 GR CF8M
98	BONNET STUDS	ASTM A193 GR B7	ASTM A193 GR B7	ASTM A193 GR B7	ASTM A193 GR B7	ASTM A193 GR B7
16b	STUD NUTS	ASTM A194 GR 2H	ASTM A194 GR 2H	ASTM A194 GR 2H	ASTM A194 GR 2H	ASTM A194 GR 2H
52	GLAND STUD	CARBON STEEL	CARBON STEEL	CARBON STEEL	CARBON STEEL	CARBON STEEL
16a	GLAND NUTS	ASTM A194 GR 2H	ASTM A194 GR 2H	ASTM A194 GR 2H	ASTM A194 GR 2H	ASTM A194 GR 2H
113	DISC THRUST PLATE	316 SS/PLATED	316 SS/PLATED	316 SS/PLATED	316 SS/PLATED	316 SS/PLATED16c
16c	NUTS	ASTM A194 GR 2H	ASTM A194 GR 2H	ASTM A194 GR 2H	ASTM A194 GR 2H	ASTM A194 GR 2H
59	GREASE FITTING	MFG STAD.	MFG STAD.	MFG STAD.	MFG STAD.	MFGSTAD
98	THREADED COL.	ASTM A193 GR B7	ASTM A193 GR B7	ASTM A193 GR B7	ASTM A193 GR B7	ASTM A193 GR B7
98a	BOLTING	ASTM A193 GR B7	ASTM A193 GR B7	ASTM A193 GR B7	ASTM A193 GR B7	ASTM A193 GR B7
98b	DRAW BOLTING	ASTM A193 GR B7	ASTM A193 GR B7	ASTM A193 GR B7	ASTM A193 GR B7	ASTM A193 GR B7
54	HANDWHEEL NUT	CARBON STEEL	CARBON STEEL	CARBON STEEL	CARBON STEEL	CARBON STEEL
128	TUBULAR COL.	CARBON STEEL	CARBON STEEL	CARBON STEEL	CARBON STEEL	CARBON STEEL
56	JAM NUT	CARBON STEEL	CARBON STEEL	CARBON STEEL	CARBON STEEL	CARBON STEEL

Pacific Valves® reserves the right to change or modify product design or construction without prior notice and without incurring any obligation to make such changes and modifications on products previously or subsequently sold.

NOTES:

1. A 309 SS inlay is furnished in the gasket area of the body on ASME class 2500 valves. For this option on other pressure classes, specify special features suffix H.
2. WCC valve bonnet and internals will be manufactured with 300 series stainless or 2¼ CR material.
3. Thrust ring comes standard on 12" and larger ASME class 1500. All sizes of ASME class 2500.

*Special high temperature packing is recommended for services over 850°F. Consult factory when ordering.

**High temperature packing is standard.

***Graphite Pressure Seal Bonnet Gasket standard. Mild Steel Silver Plated available on request.



Dimensions Globe Stop & Stop-Check Valves • ASME Class 900

Globe Stop Valves

Fig. No. **56009-7-WE*** Butt Weld Ends
 Fig. No. **56009-7** Flanged, Raised Face
 Fig. No. **56009-7-RJ** Flanged, Ring Joint

Globe Stop-Check Valves

Fig. No. **56509-7-WE*** Butt Weld Ends
 Fig. No. **56509-7** Flanged, Raised Face
 Fig. No. **56509-7-RJ** Flanged, Ring Joint

Dim	Description		VALVE SIZES (inches)								
			2	2.5	3	4	6	8	10	12	14
A	End-to-End Weld Ends	in.	12	12	12	14	20	26	31	36	39
		mm	304	304	304	355	508	660	787	914	990
A ₁	Face-to-Face Flanged Ends	in.	N/A	N/A	15	18	24	29	33	38	40.5
		mm	N/A	N/A	381	457	609	736	838	965	1028
A ₂	Face-to-Face RTJ	in.	N/A	N/A	15.13	18.13	24.13	29.13	33.13	38.13	40.88
		mm	N/A	N/A	384	460	612	739	841	968	1039
K	Center-to-Top Open	in.	18	18	18	23	33	39	46	52	60
		mm	457	457	457	584	825	990	1186	1320	1524
M	Handwheel Dia.	in.	16	16	16	16	28	28	36	36	36
		mm	406	406	406	406	711	711	914	914	914
**	Weight Weld Ends	lbs	90	90	90	198	576	965	1603	2272	3384
		kg	41	41	41	90	261	437	727	1030	1534
**	Weight Flanged Ends	lbs	N/A	N/A	150	275	765	1325	2050	2920	4430
		kg	N/A	N/A	68	124	346	600	929	1324	2009

NOTE:

1. Integral body seat on 2" through 4" size.

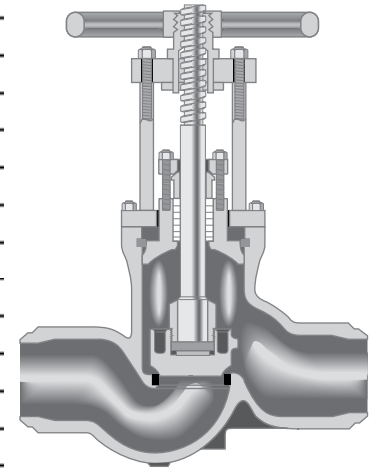

VENTURI GLOBE STOP AND STOP-CHECK VALVES

Globe Stop Valves Fig. No. **56009-7-WE*** Butt Weld Ends

Globe Stop-Check Valves Fig. No. **56509-7-WE*** Butt Weld Ends

Dim	Description		VALVE SIZES (inches)				
			8x6x8	10x8x10	12x10x12	14x12x14	16x14x16
A	End-to-End	in.	24	29	33	38	40.5
		mm	609	736	838	965	1028
K	Center-to-Top Open	in.	33	39	46	52	60
		mm	825	990	1168	1320	1524
M	Handwheel Dia.	in.	28	28	36	36	36
		mm	711	711	914	914	914
**	Weight	lbs	580	979	1628	2340	3424
		kg	263	444	738	1061	1553

General Notes:

- Dimensions, weights, and other engineering data are subject to change or modification. This data is not to be used for construction unless confirmed by Pacific Valves®.
- For best performance, size for full open operation. See Flow Calculations in the Technical Data Section.
 * Specify pipe schedule.
 **Weight includes standard bevel gear where applicable.
- Related data available in Technical Data, Actuators, and Accessories sections.

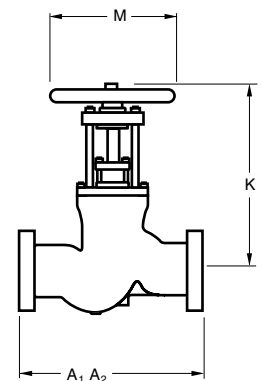
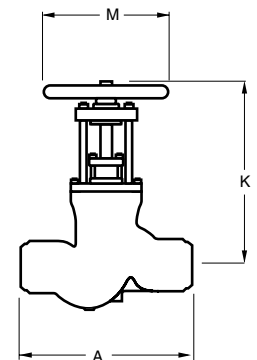



Dimensions Globe Stop & Stop-Check Valves • ASME Class 1500

Globe Stop Valves

- Fig. No. **56015-7-WE*** Butt Weld Ends
- Fig. No. **56015-7** Flanged, Raised Face
- Fig. No. **56015-7-RJ** Flanged, Ring Joint

Globe Stop-Check Valves

- Fig. No. **56515-7-WE*** Butt Weld Ends
- Fig. No. **56515-7** Flanged, Raised Face
- Fig. No. **56515-7-RJ** Flanged, Ring Joint

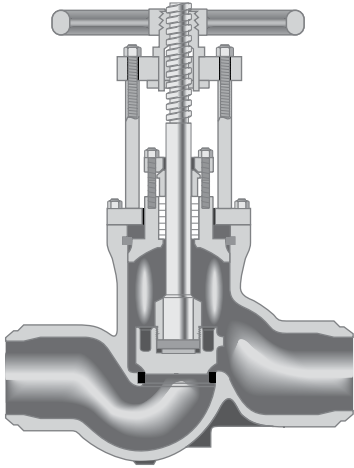

Dim	Description		VALVE SIZES (inches)							
			2	2.5	3	4	6	8	10	12
A	End-to-End Weld Ends	in.	14.5	16.5	18.5	21.5	27.75	32.75	39	44.5
		mm	368	419	469	546	704	831	990	1130
A ₁	Face-to-Face Flanged Ends	in.	16.5	16.5	18.5	21.5	27.75	32.75	39	44.5
		mm	419	419	469	546	704	831	990	1130
A ₂	Face-to-Face RTJ	in.	16.63	16.63	18.63	21.63	28	33.13	39.38	45.13
		mm	422	422	473	549	711	841	1000	1146
K	Center-to-Top Open	in.	19	19	23	27	37	47	50	57
		mm	482	482	577	685	933	1193	1270	1447
M	Handwheel Dia.	in.	16	16	16	16	28	36	36	42
		mm	406	406	406	406	711	914	914	1066
**	Weight Weld Ends	lbs	105	105	175	333	810	1381	2565	4046
		kg	47	47	79	151	367	626	1163	1835
**	Weight Flanged Ends	lbs	165	165	255	460	1110	1880	3380	5270
		kg	75	75	115	208	503	852	1533	2390

NOTE:

1. Integral body seat on 2" through 4" size.

VENTURI GLOBE STOP AND STOP-CHECK VALVES

Globe Stop Valves Fig. No. **56015-7-WE*** Butt Weld Ends

Globe Stop-Check Valves Fig No. **56515-7-WE*** Butt Weld Ends

Dim	Description		VALVE SIZES (inches)			
			8x6x8	10x8x10	12x10x12	14x12x14
A	End-to-End	in.	27.75	32.75	39	44.5
		mm	705	831	990	1130
K	Center-to-Top Open	in.	37	47	50	57
		mm	933	1193	1270	1447
M	Handwheel Dia.	in.	28	36	36	42
		mm	711	914	914	1066
**	Weight	lbs	816	1396	2595	4082
		kg	370	633	1177	1851

General Notes:

1. Dimensions, weights, and other engineering data are subject to change or modification. This data is not to be used for construction unless confirmed by Pacific Valves®.
2. For best performance, size for full open operation. See Flow Calculations in the Technical Data Section.
 - * Specify pipe schedule.
 - **Weight includes standard bevel gear where applicable.
3. Related data available in Technical Data, Actuators, and Accessories sections.

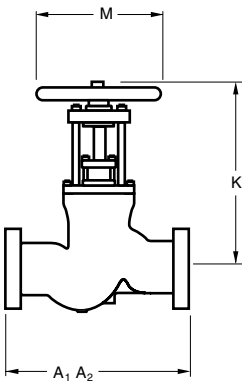
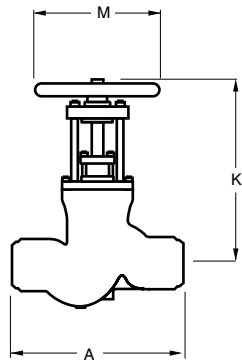



Dimensions Globe Stop & Stop-Check Valves • ASME Class 2500

Globe Stop Valves

Fig. No. **56025H-7-WE*** Butt Weld Ends
 Fig. No. **56025H-7** Flanged, Raised Face
 Fig. No. **56025H-7-RJ** Flanged, Ring Joint

Globe Stop-Check Valves

Fig. No. **56525H-7-WE*** Butt Weld Ends
 Fig. No. **56525H-7** Flanged Raised Face
 Fig. No. **56525H-7-RJ** Flanged, Ring Joint

Dim	Description		VALVE SIZES (inches)							
			2	2.5	3	4	6	8	10	12
A	End-to-End Weld Ends	in.	13	13	15	18	24	29	33	38
		mm	330	330	381	457	609	736	838	965
A ₁	Face-to-Face Flanged Ends	in.	20	20	22.75	26.5	36	40.25	50	56
		mm	508	508	578	673	914	1022	1270	1422
A ₂	Face-to-Face RTJ	in.	20.25	20.25	23	26.88	36.5	40.88	50.88	56.88
		mm	514	514	584	683	927	1039	1293	1445
K	Center-to-Top Open	in.	20	20	24	27	38	47	56	60
		mm	495	495	603	685	971	1200	1416	1524
M	Handwheel Dia.	in.	16	16	16	16	28	36	42	42
		mm	406	406	406	406	711	914	1066	1066
**	Weight Weld Ends	lbs	165	165	253	310	1013	1693	2911	4200
		kg	74	74	114	140	459	767	1320	1905
**	Weight Flanged Ends	lbs	260	260	430	575	1700	2730	4900	7300
		kg	117	117	195	260	770	1238	2222	3310

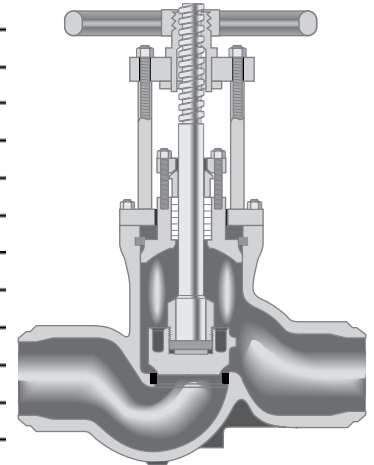

NOTE:

1. Integral body seat on 2" through 3" size.

VENTURI GLOBE STOP AND STOP-CHECK VALVES

Globe Stop Valves Fig. No. **56025H-7-WE*** Butt Weld Ends

Globe Stop-Check Valves Fig. No. **56525H-7-WE*** Butt Weld Ends

Dim	Description		VALVE SIZES (inches)			
			8x6x8	10x8x10	12x10x12	14x12x14
A	End-to-End	in.	31.25	36	40.25	50
		mm	914	1092	1244	1625
K	Center-to-Top Open	in.	38	47	56	60
		mm	971	1200	1416	1524
M	Handwheel Dia.	in.	28	36	42	42
		mm	711	914	1066	1066
**	Weight	lbs	1063	1828	3125	4460
		kg	482	829	1417	2023

NOTES:

1. Impact Handwheel standard—all sizes.

General Notes:

- Dimensions, weights, and other engineering data are subject to change or modification. This data is not to be used for construction unless confirmed by Pacific Valves®.
- For best performance, size for full open operation. See Flow Calculations in the Technical Data Section.
 * Specify pipe schedule.
 **Weight includes standard bevel gear where applicable.
- Related data available in Technical Data, Actuators, and Accessories sections.

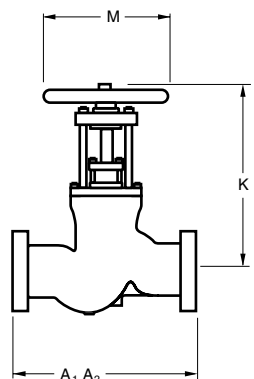
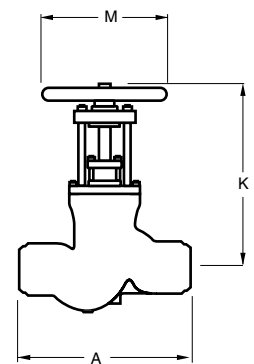



Materials Lift-Check Valves

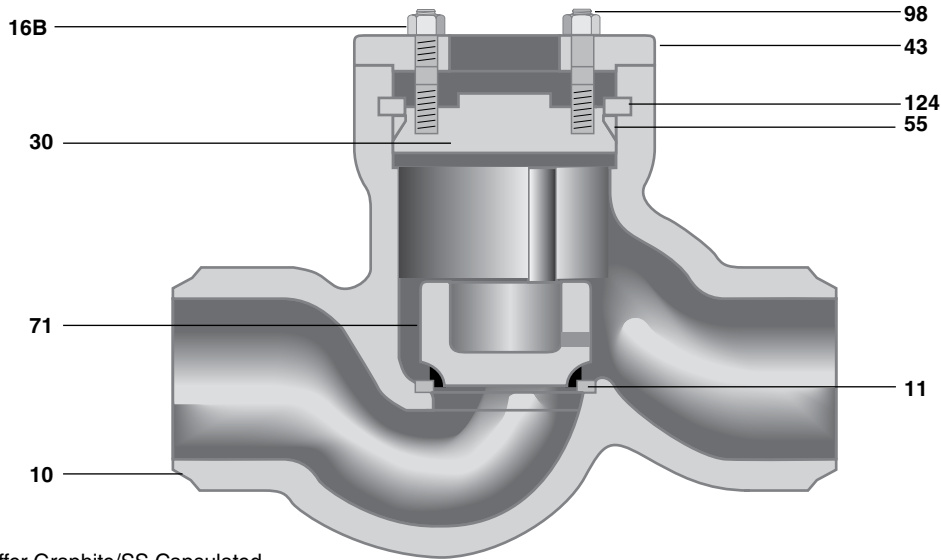

*Pacific Valves offer Graphite/SS Capsulated Pressure Seal Bonnet Gaskets as a standard, Mild Steel Silver Plated Pressure Seal Bonnet Gaskets are available on request.

NO	PART NAME	CARBON STEEL	1¼ CHROME	2¼ CHROME	9 Cr-1Mo-V	316 STAINLESS
98	BONNET STUDS	ASTM 193 GR B7	ASTM 193 GR B7	ASTM 193 GR B7	ASTM 193 GR B7	ASTM 193 GR B7
16b	STUD NUTS	ASTM A194 GR 2H	ASTM A194 GR 2H	ASTM A194 GR 2H	ASTM A194 GR 2H	ASTM A194 GR 2H
43	BONNET CARRIER	CARBON STEEL	CARBON STEEL	CARBON STEEL	CARBON STEEL	CARBON STEEL
124	SEGMENT RING	AISI 4340 OR 4140	AISI 4340 OR 4140	AISI 4340 OR 4140	AISI 4340 OR 4140	AISI 4340 OR 4140
73	THRUST RING ³	AISI 4340 OR 4140	AISI 4340 OR 4140	AISI 4340 OR 4140	AISI 4340 OR 4140	AISI 4340 OR 4140
55	GASKET	GRAPHITE/SS CAPS OR MILD STEEL SILVER PLATED*	GRAPHITE/SS CAPS OR MILD STEEL SILVER PLATED*	GRAPHITE/SS CAPS OR MILD STEEL SILVER PLATED*	GRAPHITE/SS CAPS OR MILD STEEL SILVER PLATED*	GRAPHITE/SS CAPS OR MILD STEEL SILVER PLATED*
30	BONNET CAP	CARBON STEEL	ASTM A182 GR F22	ASTM A182 GR F22	ASTM A182 GR F91	ASTM A182 GR F316
71	DISC	CARBON STEEL W/CO-CR OVERLAY	316 SS OR 2¼ CR W/CO-CR OVERLAY	316 SS OR 2¼ CR W/CO-CR OVERLAY	316 SS W/CO-CR OVERLAY	316L W/CO-CR OVERLAY
10	BODY ¹	ASTM A216 GR WCB or WCC ²	ASTM A217 GR WC6	ASTM A217 GR WC9	ASTM A217 GR C12A	ASTM A351 GR CF8M
11	SEAT RING	CARBON STEEL W/CO-CR OVERLAY	316 SS OR 2¼ CR W/CO-CR OVERLAY	316 SS OR 2¼ CR W/CO-CR OVERLAY	ALLOY 91 W/CO-CR OVERLAY	316L SS W/CO-CR OVERLAY

Pacific Valves® reserves the right to change or modify product design or construction without prior notice and without incurring any obligation to make such changes and modifications on products previously or subsequently sold.

- NOTES:**
1. A 309 SS inlay is furnished as a standard in the gasket area of the body on ASME class 2500 valves. For this option on other pressure classes, specify special features suffix H.
 2. WCC valve bonnet and internals will be manufactured with 300 series stainless or 2¼ CR material.
 3. Thrust ring comes standard on 12" and larger ASME class 1500 and all sizes of ASME class 2500.

*Graphite Pressure Seal Bonnet Gasket standard. Mild Steel Silver Plated available on request.



Dimensions Lift-Check Valves • ASME Class 900

Fig. No. **58609-7-WE*** Butt Weld Ends
 Fig. No. **58609-7** Flanged, Raised Face
 Fig. No. **58609-7-RJ** Flanged, Ring Joint

Dim	Description		VALVE SIZES (inches)								
			2	2.5	3	4	6	8	10	12	14
A	End-to-End Weld Ends	in.	12	12	12	14	20	26	31	36	39
		mm	304	304	304	355	508	660	787	914	990
A ₁	Face-to-Face Flanged Ends	in.	N/A	N/A	15	18	24	29	33	38	40.5
		mm	N/A	N/A	381	457	609	736	838	965	1028
A ₂	Face-to-Face RTJ	in.	N/A	N/A	15.13	18.13	24.13	29.13	33.13	38.13	40.88
		mm	N/A	N/A	384	460	612	739	841	968	1039
K	Center-to-Top Open	in.	6	6	6	7	12	15	17	21	24
		mm	152	152	152	184	292	381	425	533	603
	Weight Weld Ends	lbs	49	49	49	103	299	588	978	1517	2036
		kg	22	22	22	46	135	266	443	688	923
	Weight Flanged Ends	lbs	N/A	N/A	109	180	324	948	1425	2165	3082
		kg	N/A	N/A	49	82	147	430	646	982	1398

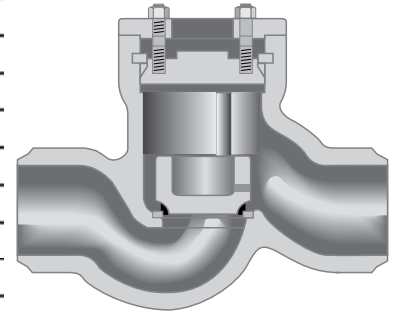

NOTE:

1. Integral body seat on 2" through 4".

VENTURI LIFT-CHECK VALVES

Fig. No. **58615-7-WE*** Butt Weld Ends

Dim	Description		VALVE SIZES (inches)				
			8x6x8	10x8x10	12x10x12	14x12x14	16x14x16
A	End-to-End	in.	24	29	33	38	40.5
		mm	609	736	838	965	1028
K	Center-to-Top Open	in.	12	15	17	21	24
		mm	292	381	425	533	603
	Weight	lbs	303	602	1003	1549	2076
		kg	137	373	455	702	941

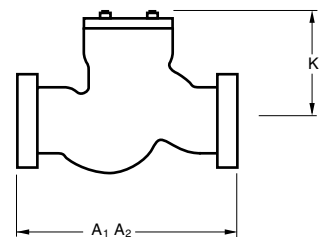
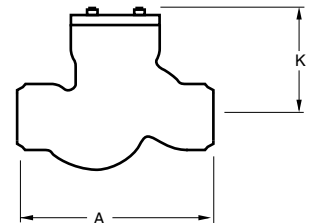

General Notes:

1. Dimensions, weights, and other engineering data are subject to change or modification. This data is not to be used for construction unless confirmed by Pacific Valves®.
2. For best performance, size for full open operation. See Flow Calculations in the Technical Data Section.
* Specify pipe schedule.
3. Related data available in Technical Data, Actuators, and Accessories sections.



Dimensions Lift-Check Valves • ASME Class 1500

- Fig. No. **58615-7-WE*** Butt Weld Ends
- Fig. No. **58615-7** Flanged, Raised Face
- Fig. No. **58615-7-RJ** Flanged, Ring Joint

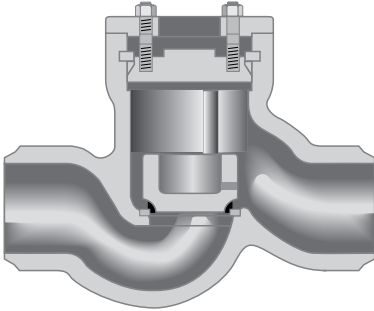

Dim	Description	VALVE SIZES (inches)								
		2	2.5	3	4	6	8	10	12	
A	End-to-End Weld Ends	in.	14.5	16.5	18.5	21.5	27.75	32.75	39	44.5
		mm	368	419	469	546	705	831	990	1130
A ₁	Face-to-Face Flanged Ends	in.	16.5	16.5	18.5	21.5	27.75	32.75	39	44.5
		mm	419	419	470	546	705	832	991	1130
A ₂	Face-to-Face RTJ	in.	16.63	16.63	18.63	21.63	28	33.13	39.38	45.13
		mm	422	422	473	549	711	841	1000	1146
K	Center-to-Top	in.	6	6	7	8	12	16	19	21
		mm	152	152	177	203	311	400	488	533
	Weight Weld Ends	lbs	53	53	87	141	424	824	1414	2246
		kg	24	24	39	63	192	373	641	1018
	Weight Flanged Ends	lbs	113	113	167	268	724	1323	2229	3470
		kg	51	51	75	121	328	600	1011	1574

NOTE:

1. Integral body seat on 2" through 4" size.

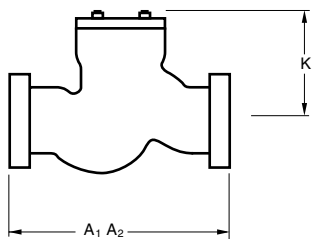
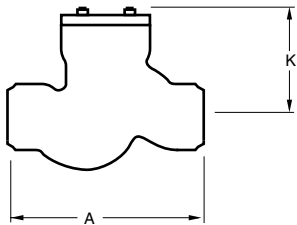

VENTURI LIFT-CHECK VALVES

Fig. No. **58609-7-WE*** Butt Weld Ends

Dim	Description	VALVE SIZES (inches)				
		8x6x8	10x8x10	12x10x12	14x12x14	
A	End-to-End	in.	27.75	32.75	39	44.5
		mm	705	831	990	1130
K	Center-to-Top Open	in.	12	16	19	21
		mm	311	400	488	533
	Weight	lbs	430	840	1444	2282
		kg	195	381	855	1036

General Notes:

1. Dimensions, weights, and other engineering data are subject to change or modification. This data is not to be used for construction unless confirmed by Pacific Valves®.
2. For best performance, size for full open operation. See Flow Calculations in the Technical Data Section.
* Specify pipe schedule.
3. Related data available in Technical Data, Actuators, and Accessories sections.



Dimensions Lift-Check Valves • ASME Class 2500

Fig. No. **58625H-7-WE*** Butt Weld Ends
 Fig. No. **58625H-7** Flanged, Raised Face
 Fig. No. **58625H-7-RJ** Flanged, Ring Joint

Dim	Description		VALVE SIZES (inches)							
			2	2.5	3	4	6	8	10	12
A	End-to-End Weld Ends	in.	13	13	15	18	24	29	33	38
		mm	330	330	381	457	609	736	838	965
A1	Face-to-Face Flanged Ends	in.	20	20	22.75	26.5	36	40.25	50	56
		mm	508	508	578	673	914	1022	1270	1422
A2	Face-to-Face RTJ	in.	20.25	20.25	23	26.88	36.5	40.88	50.88	56.88
		mm	514	514	584	683	927	1039	1293	1445
K	Center-to-Top	in.	7	7	8	10	13	17	20	22
		mm	171	171	196	241	323	425	508	552
	Weight Weld Ends	lbs	78	78	121	151	527	900	1700	2801
		kg	35	35	55	68	239	408	771	1270
	Weight Flanged Ends	lbs	173	173	298	416	1214	1937	3689	5901
		kg	78	78	135	189	550	878	1673	2676

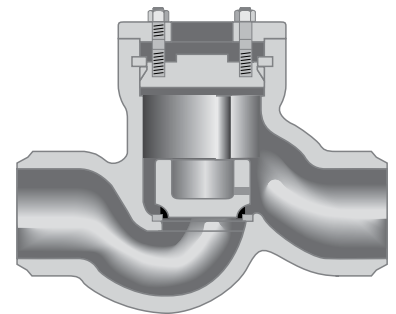

NOTE:

1. Integral body seat on 2" through 3" size.

VENTURI LIFT-CHECK VALVES

Fig. No. **58625H-7-WE*** Butt Weld Ends

Dim	Description		VALVE SIZES (inches)			
			8x6x8	10x8x10	12x10x12	14x12x14
A	End-to-End	in.	36	43	49	64
		mm	914	1092	1244	1625
K	Center-to-Top Open	in.	13	17	20	22
		mm	323	425	508	552
	Weight	lbs	577	1035	1914	3061
		kg	261	469	868	1388

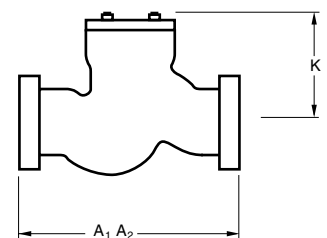
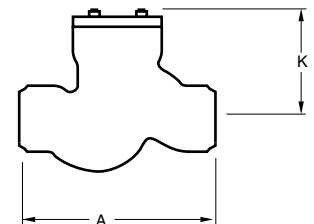

General Notes:

1. Dimensions, weights, and other engineering data are subject to change or modification. This data is not to be used for construction unless confirmed by Pacific Valves®.
2. For best performance, size for full open operation. See Flow Calculations in the Technical Data Section.
* Specify pipe schedule.
3. Related data available in Technical Data, Actuators, and Accessories sections.



Materials Y-Globe Valves

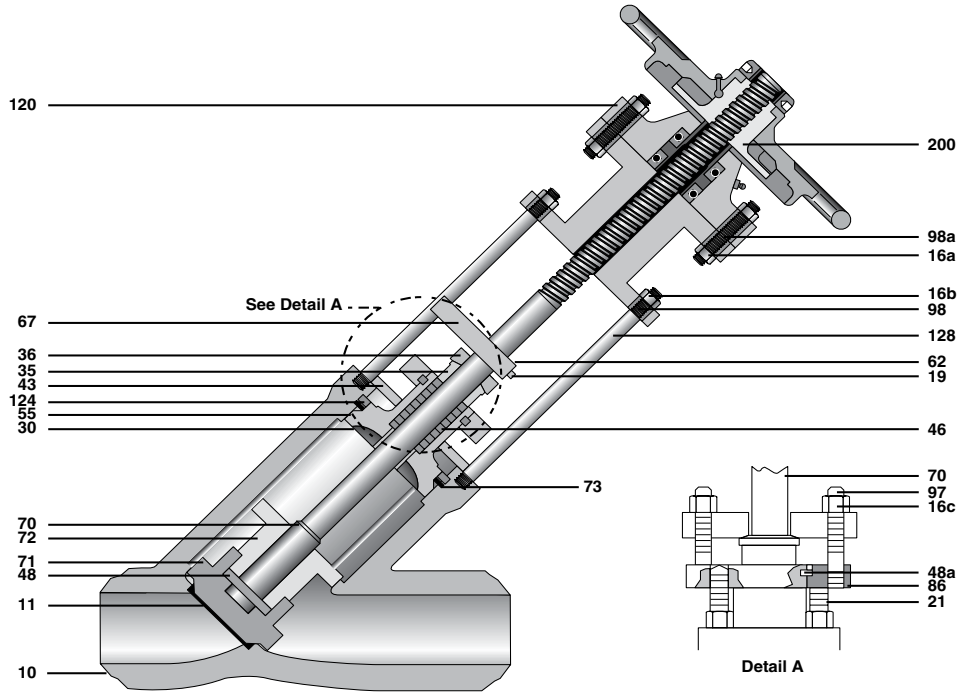

NO	PART NAME	CARBON STEEL	1¼ CHROME	2¼ CHROME	9Cr-1Mo-V	316 STAINLESS
10	BODY	ASTM A216 GR WCB OR WCC¹ W/CO-CR	ASTM A217 GR WC6 W/CO-CR	ASTM A217 GR WC9 W/CO-CR	ASTM A217 GR C12A W/CO-CR	ASTM A351 GR CF8M W/CO-CR
11	SEAT RINGS	CARBON STEEL W/ CO-CR OVERLAY	316 SS OR 2¼ CR W/ CO-CR OVERLAY	316 SS OR 2¼ CR W/ CO-CR OVERLAY	ALLOY 91 W/ CO-CR OVERLAY	316L W/CO-CR OVERLAY
16a	NUT	ASTM A194 GR 2H	ASTM A194 GR 2H	ASTM A194 GR 2H	ASTM A194 GR 2H	ASTM A194 GR 2H
16b	NUT	ASTM A194 GR 2H	ASTM A194 GR 2H	ASTM A194 GR 2H	ASTM A194 GR 2H	ASTM A194 GR 2H
16c	NUT	ASTM A194 GR 2H	ASTM A194 GR 2H	ASTM A194 GR 2H	ASTM A194 GR 2H	ASTM A194 GR 2H
19	SCREW	A193 GR B7	A193 GR B7	A193 GR B7	A193 GR B7	A193 GR B7
21	JACKING BOLTS	A582 GR 416	A582 GR 416	A582 GR 416	A582 GR 416	A582 GR 416
73	THRUST RING²	AISI 4140 OR 4340	AISI 4140 OR 4340	AISI 4140 OR 4340	AISI 4140 OR 4340	AISI 4140 OR 4340
30	BONNET	CARBON STEEL W/ CO-CR	ASTM A182 GR F22 W/ CO-CR	ASTM A182 GR F22 W/ CO-CR	ASTM A182 GR F91 W/ CO-CR	ASTM A182 GR F316 W/ CO-CR
35	GLAND	12% CHROME	12% CHROME	12% CHROME	12% CHROME	300 SERIES SST
36	GLAND FLANGE	CARBON STEEL	CARBON STEEL	CARBON STEEL	CARBON STEEL	CARBON STEEL
43	LOWER PLATE	CARBON STEEL	CARBON STEEL	CARBON STEEL	CARBON STEEL	CARBON STEEL
46	PACKING	GRAPHITIC	GRAPHITIC	GRAPHITIC	GRAPHITIC	GRAPHITIC
48	RETAINER	11-13% CHROME	11-13% CHROME	11-13% CHROME	11-13% CHROME	11-13% CHROME
48a	RETAINER	316 SS	316 SS	316 SS	316 SS	316 SS
55	GASKET	GRAPHITE/SS CAPS OR MILD STEEL SILVER PLATED*	GRAPHITE/SS CAPS OR MILD STEEL SILVER PLATED*	GRAPHITE/SS CAPS OR MILD STEEL SILVER PLATED*	GRAPHITE/SS CAPS OR MILD STEEL SILVER PLATED*	GRAPHITE/SS CAPS OR MILD STEEL SILVER PLATED*
62	KEY	AISI 01	AISI 01	AISI 01	AISI 01	AISI 01
67	STEM GUIDE	CARBON STEEL	CARBON STEEL	CARBON STEEL	CARBON STEEL	CARBON STEEL
70	STEM	ASTM A582 GR 416	ASTM A582 GR 416	ASTM A582 GR 416	ASTM A582 GR 416	ASTM A705 GR 630
71	DISC	CARBON STEEL W/ CO-CR OVERLAY	316 SS OR 1¼ CR W/ CO-CR OVERLAY	316 SS OR 2¼ CR W/ CO-CR OVERLAY	316 SS W/ CO-CR OVERLAY	316L SS W/ CO-CR OVERLAY
72	DISC NUT	CARBON STEEL W/ CO-CR OVERLAY	316 SS OR 1¼ CR W/ CO-CR OVERLAY	316 SS OR 2¼ CR W/ CO-CR OVERLAY	316 SS W/ CO-CR OVERLAY	316L SS W/ CO-CR OVERLAY
86	CARRIER	CARBON STEEL	CARBON STEEL	CARBON STEEL	CARBON STEEL	CARBON STEEL
97	BOLT	ASTM A193 GR B7	ASTM A193 GR B7	ASTM A193 GR B7	ASTM A193 GR B7	ASTM A193 GR B7
98	BOLT	ASTM A193 GR B7	ASTM A193 GR B7	ASTM A193 GR B7	ASTM A193 GR B7	ASTM A193 GR B7
98a	BOLT	ASTM A193 GR B7	ASTM A193 GR B7	ASTM A193 GR B7	ASTM A193 GR B7	ASTM A193 GR B7
120	ADAPTER	CARBON STEEL	CARBON STEEL	CARBON STEEL	CARBON STEEL	CARBON STEEL
124	SEGMENT RING	AISI 4140 OR 4340	AISI 4140 OR 4340	AISI 4140 OR 4340	AISI 4140 OR 4340	AISI 4140 OR 4340
128	COLUMN	CARBON STEEL	CARBON STEEL	CARBON STEEL	CARBON STEEL	CARBON STEEL
200	ACTUATOR	CONSULT FACTORY	CONSULT FACTORY	CONSULT FACTORY	CONSULT FACTORY	CONSULT FACTORY

Pacific Valves® reserves the right to change or modify product design or construction without prior notice and without incurring any obligation to make such changes and modifications on products previously or subsequently sold.

NOTES:

1. WCC valve bonnets and internals will be manufactured with 300 series SS and/or 2¼ CR.
2. Thrust ring on all 12" and larger 1500 and all 2500.

*Graphite Pressure Seal Bonnet Gasket standard. Mild Steel Silver Plated available on request.



Dimensions Y-Globe Stop & Stop-Check Valves • ASME Class 600

Y-Globe Stop Valves

Fig. No. 59006-7-WE* Butt Weld Ends

Y-Globe Stop-Check Valves

Fig. No. 59506-7-WE* Butt Weld Ends

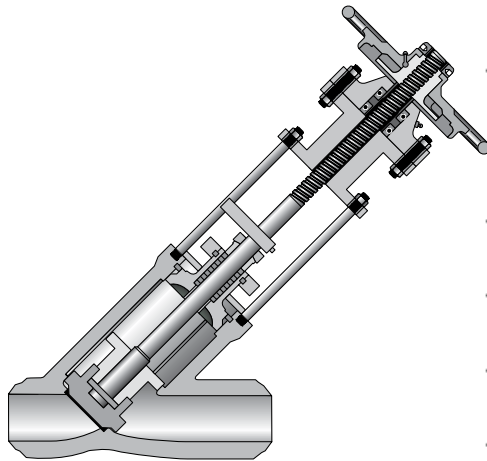

Dim	Description		VALVE SIZES (inches)							
			6-8	10	12	14	16	18	20	24
A	End-to-End Weld Ends	in.	23.00	28.00	32.00	32.00	41.00	41.00	60.00	66.00
		mm	584	711	813	813	1041	1041	1524	1676
K	Center-to-Top	in.	25.50	35.38	45.56	45.56	77.00	77.00	85.63	108.00
		mm	648	899	1157	1157	1956	1956	2175	2743
M	Handwheel Dia.	in.	28	36	48	48	48	72	72	72
		mm	711	914	1219	1219	1219	1829	1829	1829
	Weight Weld Ends	lbs	820	1830	2560	2560	5570	5570	7500	13500
		kg	372	830	1161	1161	2527	2527	3398	6116

VENTURI Y-GLOBE STOP AND STOP-CHECK VALVES

Y-Globe Stop Valves Fig. No. 59006-7-WE* Butt Weld Ends

Y-Globe Stop-Check Valves Fig. No. 59506-7-WE* Butt Weld Ends

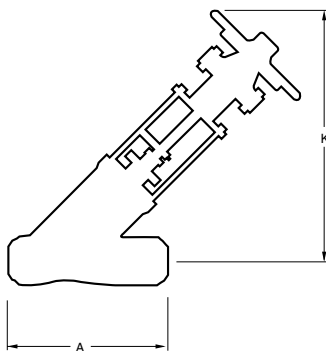

Dim	Description		VALVE SIZES (inches)							
			10x8x10	12x10x12	14x12x14	16x14x16	18x16x18	20x18x20	22x20x22	26x24x26
A	End-to-End Weld Ends	in.	23.00	28.00	32.00	32.00	41.00	41.00	60.00	66.00
		mm	584	711	813	813	1041	1041	1524	1676
K	Center-to-Top	in.	25.50	35.38	45.56	45.56	77.00	77.00	85.63	108.00
		mm	648	899	1157	1157	1956	1956	2175	2743
M	Handwheel Dia.	in.	28	36	48	48	48	72	72	72
		mm	711	914	1219	1219	1219	1829	1829	1829
	Weight Weld Ends	lbs	900	2025	2825	2825	6125	6125	6600	7900
		kg	408	918	1281	1281	2778	2778	2994	3583

General Notes:

- Dimensions, weights, and other engineering data are subject to change or modification. This data is not to be used for construction unless confirmed by Pacific Valves®.
- For best performance, size for full open operation. See Flow Calculations in the Technical Data Section.
* Specify pipe schedule.
- Related data available in Technical Data, Actuators, and Accessories sections.
- Valves supplied with hammerblow handwheel as a standard.



Dimensions Y-Globe Stop & Stop-Check Valves • ASME Class 900

Y-Globe Stop Valves

Fig. No. 59009-7-WE* Butt Weld Ends

Y-Globe Stop-Check Valves

Fig. No. 59509-7-WE* Butt Weld Ends

Dim	Description		VALVE SIZES (inches)								
			6	8	10	12	14	16	18	20	24
A	End-to-End Weld Ends	in.	27.75	30.00	36.25	42.5	43.00	54.00	63.00	54.50	59.50
		mm	705	762	921	1041	1092	1372	1600	1384	1511
K	Center-to-Top	in.	40.47	53.38	63.58	77.84	77.84	89.62	98.11	110.97	110.83
		mm	1028	1356	1615	1977	1977	2276	2492	2819	2815
M	Handwheel Dia.	in.	28	28	36	48	48	48	72	72	72
		mm	711	711	914	1219	1219	1219	1829	1829	1829
	Weight Weld Ends	lbs	810	1560	2900	3950	3950	7700	7825	9800	16000
		kg	367	709	1318	1795	1795	3495	3550	4446	7273

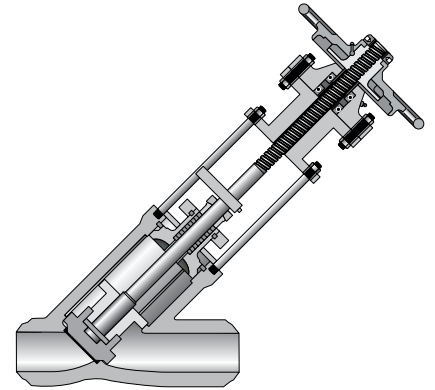

VENTURI Y-GLOBE STOP AND STOP-CHECK VALVES

Y-Globe Stop Valves Fig. No. 59009-7-WE* Butt Weld Ends

Y-Globe Stop-Check Valves Fig. No. 59509-7-WE* Butt Weld Ends

Dim	Description		VALVE SIZES (inches)								
			8x6x8	10x8x10	12x10x12	14x12x14	16x14x16	18x16x18	20x18x20	22x20x22	26x24x26
A	End-to-End Weld Ends	in.	27.75	30.00	36.25	42.5	43.00	54.00	63.00	54.50	61.50
		mm	705	762	921	1014	1092	1372	1600	1384	1562
K	Center-to-Top	in.	40.47	53.38	63.58	77.84	77.84	89.62	98.11	110.97	110.83
		mm	1028	1356	1615	1977	1977	2276	2492	2819	2815
M	Handwheel Dia.	in.	28	28	36	48	48	48	72	72	72
		mm	711	711	914	1219	1219	1219	1829	1829	1829
	Weight Weld Ends	lbs	810	1500	2900	4100	4100	8000	8000	13000	16000
		kg	367	675	1305	1845	1845	3600	3600	5850	7200

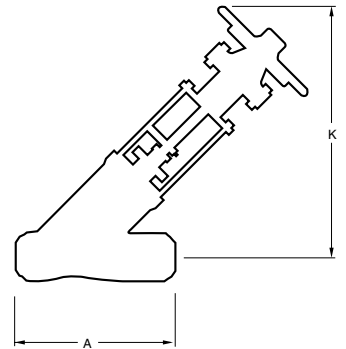

General Notes:

- Dimensions, weights, and other engineering data are subject to change or modification. This data is not to be used for construction unless confirmed by Pacific Valves®.
- For best performance, size for full open operation. See Flow Calculations in the Technical Data Section.
* Specify pipe schedule.
- Related data available in Technical Data, Actuators, and Accessories sections.
- Valves supplied with hammerblow handwheel as a standard.



Dimensions Y-Globe Stop & Stop-Check Valves • ASME Class 1500

Y-Globe Stop Valves

Fig. No. 59015-7-WE* Butt Weld Ends

Y-Globe Stop-Check Valves

Fig. No. 59515-7-WE* Butt Weld Ends

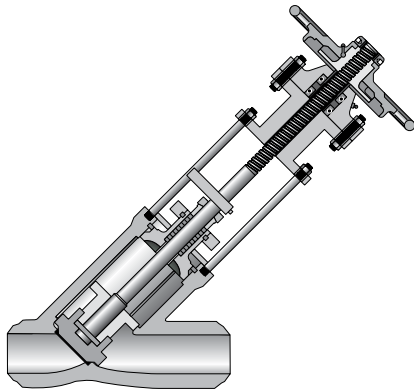

Dim	Description	VALVE SIZES (inches)									
		6	8	10	12	14	16	18	20	24	
A	End-to-End Weld Ends	in.	27.75	30.00	36.25	41.00	43.00	54.00	63.00	54.50	59.50
		mm	705	762	921	1041	1092	1372	1600	1384	1511
K	Center-to-Top	in.	40.47	53.38	63.58	77.84	77.84	89.62	98.11	110.97	110.83
		mm	1028	1356	1615	1977	1977	2276	2492	2819	2815
M	Handwheel Dia.	in.	28	28	36	48	48	48	72	72	72
		mm.	711	711	914	1219	1219	1219	1829	1829	1829
	Weight Weld Ends	lbs	810	1560	2900	3950	3950	7700	7825	9800	16000
		kg	367	709	1318	1795	1795	3494	3550	4446	7273

VENTURI Y-GLOBE STOP AND STOP-CHECK VALVES

Y-Globe Stop Valves Fig. No. 59015-7-WE* Butt Weld Ends

Y-Globe Stop-Check Valves Fig. No. 59515-7-WE* Butt Weld Ends

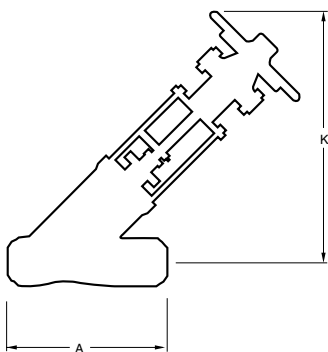

Dim	Description	VALVE SIZES (inches)									
		8x6x8	10x8x10	12x10x12	14x12x14	16x14x16	18x16x18	20x18x20	22x20x22	26x24x26	
A	End-to-End Weld Ends	in.	27.75	30.00	36.25	41.00	43.00	54.00	63.00	54.50	61.50
		mm	705	762	921	1014	1092	1372	1600	1384	1562
K	Center-to-Top	in.	40.47	53.38	63.58	77.84	77.84	89.62	98.11	110.97	110.83
		mm	1028	1356	1615	1977	1977	2276	2492	2819	2815
M	Handwheel Dia.	in.	28	28	36	48	48	48	72	72	72
		mm	711	711	914	1219	1219	1219	1829	1829	1829
	Weight Weld Ends	lbs	890	1730	3220	4380	4380	8470	8600	10750	17000
		kg	404	786	1464	1991	1991	3843	3900	4877	7727

General Notes:

- Dimensions, weights, and other engineering data are subject to change or modification. This data is not to be used for construction unless confirmed by Pacific Valves®.
- For best performance, size for full open operation. See Flow Calculations in the Technical Data Section.
* Specify pipe schedule.
- Related data available in Technical Data, Actuators, and Accessories sections.
- Valves supplied with hammerblow handwheel as a standard.



Dimensions Y-Globe Stop & Stop-Check Valves • ASME Class 2500

Y-Globe Stop Valves

Fig. No. 59025H-7-WE* Butt Weld Ends

Y-Globe Stop-Check Valves

Fig. No. 59525H-7-WE* Butt Weld Ends

Dim	Description		VALVE SIZES (inches)								
			6	8	10	12	14	16	18	20	24
A	End-to-End Weld Ends	in.	30.00	30.00	36.00	41.00	48.75	48.75	58.00	58.00	68.00
		mm	762	762	914	1041	1238	1238	1473	1473	1727
K	Center-to-Top	in.	54.36	54.36	61.08	72.04	78.07	78.07	97.99	97.99	113.75
		mm	1381	1381	1551	1830	1983	1983	2489	2489	2889
M	Handwheel Dia.	in.	28	28	36	36	48	48	72	72	72
		mm	711	711	914	914	1219	1219	1829	1829	1829
	Weight Weld Ends	lbs	1650	1650	3290	4745	7600	7600	11300	11300	17500
		kg	750	750	1348	2157	3448	3448	5136	6864	7940

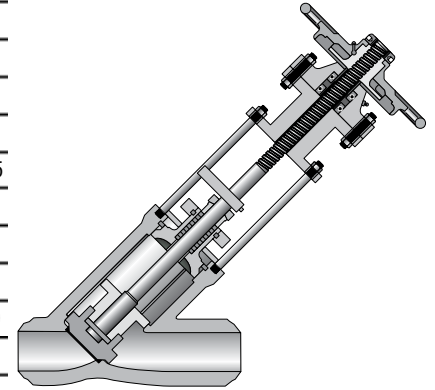

VENTURI Y-GLOBE STOP AND STOP-CHECK VALVES

Y-Globe Stop Valves Fig. No. 59025H-7-WE* Butt Weld Ends

Y-Globe Stop-Check Valves Fig No. 59525H-7-WE* Butt Weld Ends

Dim	Description		VALVE SIZES (inches)								
			8x6x8	10x8x10	12x10x12	14x12x14	16x14x16	18x16x18	20x18x20	22x20x22	26x24x26
A	End-to-End Weld Ends	in.	30.00	30.00	36.00	41.00	48.75	48.75	58.00	58.00	68.00
		mm	762	762	914	1041	1238	1238	1473	1473	1727
K	Center-to-Top	in.	54.36	54.36	61.08	72.04	78.07	78.07	97.99	97.99	113.75
		mm	1381	1381	1551	1830	1983	1983	2489	2489	2889
M	Handwheel Dia.	in.	28	28	48	48	48	48	72	72	72
		mm	711	711	1219	1219	1219	1219	1829	1829	1829
	Weight Weld Ends	lbs	1865	1865	3267	5270	8360	8360	12000	12000	19250
		kg	846	846	1482	2395	3793	3793	5455	5455	8734

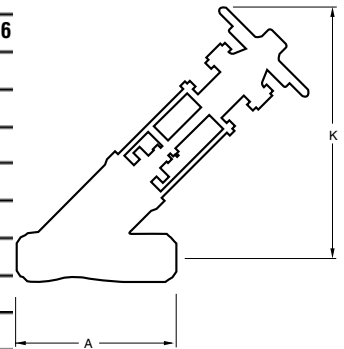

General Notes:

1. Dimensions, weights, and other engineering data are subject to change or modification. This data is not to be used for construction unless confirmed by Pacific Valves®.
2. For best performance, size for full open operation. See Flow Calculations in the Technical Data Section.
* Specify pipe schedule.
3. Related data available in Technical Data, Actuators, and Accessories sections.
4. Valves supplied with hammerblow handwheel as a standard.



Materials Y-Lift Check Valves

Y-Lift-Check Valve

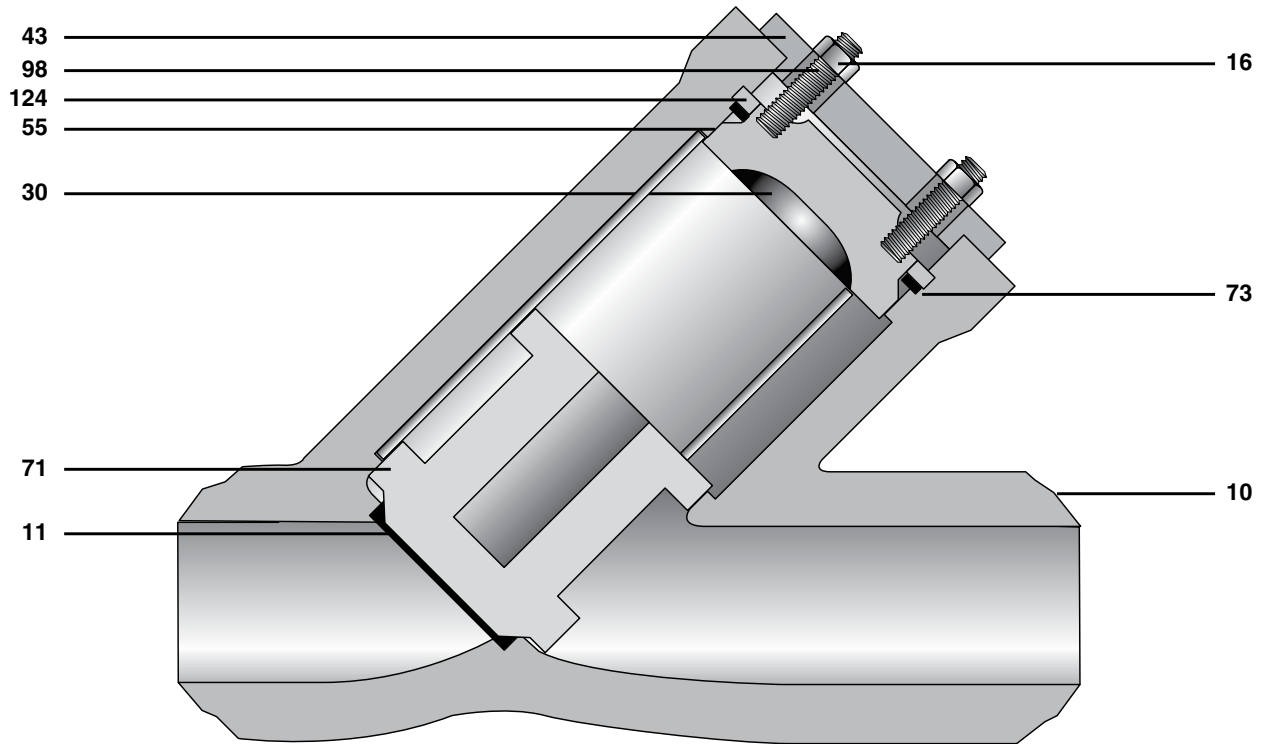

NO	PART NAME	CARBON STEEL	1¼ CHROME	2¼ CHROME	9Cr-1Mo-V	316 STAINLESS
10	BODY	ASTM A216 GR WCB OR WCC ¹ W/CO-CR	ASTM A217 GR WC6 W/CO-CR	ASTM A217 GR WC9 W/CO-CR	ASTM A217 GR C12A W/CO-CR	ASTM A351 GR CF8M W/CO-CR
11	SEAT RINGS	CARBON STEEL W/ CO-CR OVERLAY	316L SS OR 2¼ CR W/ CO-CR OVERLAY	316L SS OR 2¼ CR W/ CO-CR OVERLAY	ALLOY 91 W/ CO-CR OVERLAY	316L SS W/ CO-CR OVERLAY
16	STUD NUTS	ASTM A194 GR 2H	ASTM A194 GR 2H	ASTM A194 GR 2H	ASTM A194 GR 2H	ASTM A194 GR 2H
19	SCREW	A193 GR B7	A193 GR B7	A193 GR B7	A193 GR B7	A193 GR B7
30	BONNET CAP	CARBON STEEL	ASTM A182 GR F11/F22	ASTM A182 GR F22 W/	ASTM A182 GR F91 W/	ASTM A182 GR F316 W/
43	BONNET CARRIER	CARBON STEEL	CARBON STEEL	CARBON STEEL	CARBON STEEL	CARBON STEEL
55	GASKET	GRAPHITE/SS CAPS OR MILD STEEL SILVER PLATED*	GRAPHITE/SS CAPS OR MILD STEEL SILVER PLATED*	GRAPHITE/SS CAPS OR MILD STEEL SILVER PLATED*	GRAPHITE/SS CAPS OR MILD STEEL SILVER PLATED*	GRAPHITE/SS CAPS OR MILD STEEL SILVER PLATED*
71	DISC	CARBON STEEL W/CO-CR	316L SS OR 2¼ CR W/CO-CR	316L SS OR 2¼ CR W/CO-CR	316L SS W/CO-CR	316L SS W/CO-CR
73	THRUST RING ²	AISI 4140/4340	AISI 4140/4340	AISI 4140/4340	AISI 4140/4340	AISI 4140/4340
98	BONNET STUDS	ASTM A193 GR B7	ASTM A193 GR B7	ASTM A193 GR B7	ASTM A193 GR B7	ASTM A193 GR B7
98a	BOLT	ASTM A193 GR B7	ASTM A193 GR B7	ASTM A193 GR B7	ASTM A193 GR B7	ASTM A193 GR B7
124	SEGMENT RING	AISI 4140 OR 4340	AISI 4140 OR 4340	AISI 4140 OR 4340	AISI 4140 OR 4340	AISI 4140 OR 4340

Pacific Valves® reserves the right to change or modify product design or construction without prior notice and without incurring any obligation to make such changes and modifications on products previously or subsequently sold.

NOTES:

1. WCC valve bonnets and internals will be manufactured with 300 series SS and/or 2¼ CR.
2. Thrust ring comes standard on 12" and larger ASME class 1500 and all sizes of ASME class 2500.

*Graphite Pressure Seal Bonnet Gasket standard. Mild Steel Silver Plated available on request.



Dimensions Y-Lift-Check Valves • ASME Class 600

Y-Lift-Check Valves

Fig. No. 59606-7-WE* Butt Weld Ends

Dim	Description		VALVE SIZES (inches)								
			6	8	10	12	14	16	18	20	24
A	End-to-End Weld Ends	in	18.00	23.00	28.00	32.00	32.00	41.00	41.00	60.00	66.00
		mm	457	584	711	813	813	1041	1041	1524	1676
K	Center-to-Top	in	16.00	20.00	25.00	32.38	32.38	41.50	41.50	47.00	55.75
		mm	406	508	635	822	822	1054	1054	1194	1416
	Weight Weld Ends	lbs	400	600	1000	1450	1450	2800	2800	3500	5000
		kg	182	272	454	658	658	1270	1270	1588	2269

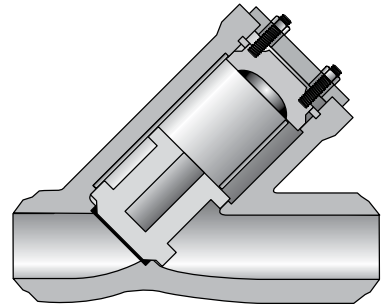

VENTURI Y-LIFT-CHECK VALVE

Y-Lift-Check Valve Fig No. 59606-7-WE* Butt Weld Ends

Dim	Description		VALVE SIZES (inches)								
			8x6x8	10x8x10	12x10x12	14x12x14	16x14x16	18x16x18	20x18x20	22x20x22	26x24x26
A	End-to-End Weld Ends	in.	18.00	23.00	28.00	32.00	32.00	41.00	41.00	60.00	66.00
		mm	457	584	711	813	813	1041	1041	1524	1676
K	Center-to-Top	in.	16.00	20.00	25.00	32.38	32.38	41.50	41.50	47.00	55.75
		mm	406	508	635	822	822	1054	1054	1194	1416
	Weight Weld Ends	lbs	400	668	1115	1595	1595	3080	3080	3900	5550
		kg	182	303	506	724	724	1397	1397	1770	2518

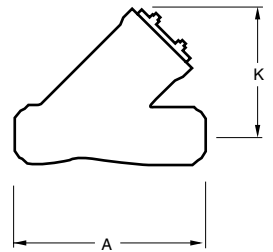

General Notes:

- Dimensions, weights, and other engineering data are subject to change or modification. This data is not to be used for construction unless confirmed by Pacific Valves®.
- For best performance, size for full open operation. See Flow Calculations in the Technical Data Section.
* Specify pipe schedule.
- Related data available in Technical Data, Actuators, and Accessories sections.



Dimensions Y-Lift Check Valves • ASME Class 900

Y-Lift-Check Valves

Fig. No. 59609-7-WE* Butt Weld Ends

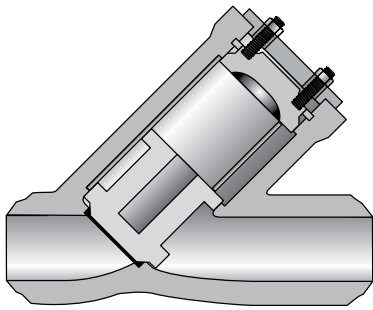

Dim	Description		VALVE SIZES (inches)								
			6	8	10	12	14	16	18	20	24
A	End-to-End Weld Ends	in	27.75	30.00	36.25	41.00	43.00	54.00	63.00	54.50	59.50
		mm	705	762	921	1041	1092	1372	1600	1384	1511
K	Center-to-Top	in	18.7	23.53	28.20	35.10	35.10	44.43	44.43	52.44	62.81
		mm	475	598	716	891	891	1129	1129	1332	1595
	Weight Weld Ends	lbs	400	624	1160	1580	1580	3080	3130	3920	5860
		kg	182	284	527	718	718	1397	1420	1782	2664

VENTURI Y-LIFT-CHECK VALVE

Y-Lift-Check Valve Fig No. 59609-7-WE* Butt Weld Ends

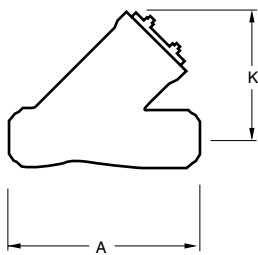

Dim	Description		VALVE SIZES (inches)								
			8x6x8	10x8x10	12x10x12	14x12x14	16x14x16	18x16x18	20x18x20	22x20x22	26x24x26
A	End-to-End Weld Ends	in.	27.75	30.00	36.25	41.00	43.00	54.00	63.00	54.50	59.50
		mm	705	762	921	1041	1092	1372	1600	1384	1511
K	Center-to-Top	in.	18.7	23.53	28.20	35.10	35.10	44.43	44.43	52.44	62.81
		mm	475	598	716	891	891	1129	1129	1332	1595
	Weight Weld Ends	lbs	400	695	1280	1750	1750	3380	3440	4350	6510
		kg	182	316	582	795	794	1534	1560	1977	2959

General Notes:

1. Dimensions, weights, and other engineering data are subject to change or modification. This data is not to be used for construction unless confirmed by Pacific Valves®.
2. For best performance, size for full open operation. See Flow Calculations in the Technical Data Section.
* Specify pipe schedule.
3. Related data available in Technical Data, Actuators, and Accessories sections.



Dimensions Y-Lift-Check Valves • ASME Class 1500

Y-Pattern Globe Lift-Check Valves

Fig. No. 59615-7-WE Butt Weld Ends

Dim	Description		VALVE SIZES (inches)								
			6	8	10	12	14	16	18	20	24
A	End-to-End Weld Ends	in	27.75	30.00	36.25	41.00	43.00	54.00	63.00	54.50	59.50
		mm	705	762	921	1041	1092	1372	1600	1384	1511
K	Center-to-Top	in	18.7	23.53	28.20	35.10	35.10	44.43	44.43	52.44	62.81
		mm	475	598	716	891	891	1129	1129	1332	1595
	Weight Weld Ends	lbs	400	624	1160	1580	1580	3080	3130	3920	5860
		kg	182	284	527	718	718	1397	1420	1782	2664

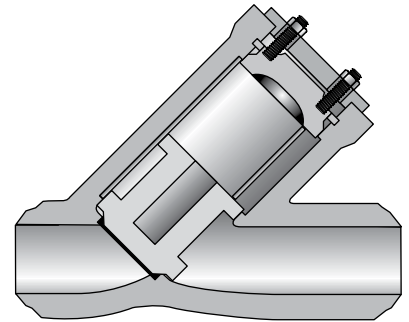

VENTURI Y-LIFT-CHECK VALVE

Y-Lift-Check Valve Fig No. 59615-7-WE* Butt Weld Ends

Dim	Description		VALVE SIZES (inches)								
			8x6x8	10x8x10	12x10x12	14x12x14	16x14x16	18x16x18	20x18x20	22x20x22	26x24x26
A	End-to-End Weld Ends	in.	27.75	30.00	36.25	41.00	43.00	54.00	63.00	54.50	59.50
		mm	705	762	921	1041	1092	1372	1600	1384	1511
K	Center-to-Top	in.	18.7	23.53	28.20	35.10	35.10	44.43	44.43	52.44	62.81
		mm	475	598	716	891	891	1129	1129	1332	1595
	Weight Weld Ends	lbs	400	695	1280	1750	1750	3380	3440	4350	6510
		kg	182	316	582	795	794	1534	1560	1977	2959

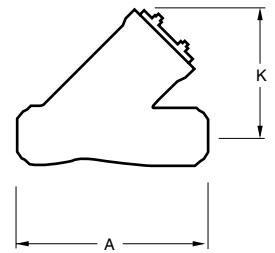

General Notes:

1. Dimensions, weights, and other engineering data are subject to change or modification. This data is not to be used for construction unless confirmed by Pacific Valves®.
2. For best performance, size for full open operation. See Flow Calculations in the Technical Data Section.
* Specify pipe schedule.
3. Related data available in Technical Data, Actuators, and Accessories sections.



Dimensions Y-Lift Check Valves • ASME Class 2500

Y-Lift-Check Valves

Fig. No. 59625H-7-WE* Butt Weld Ends

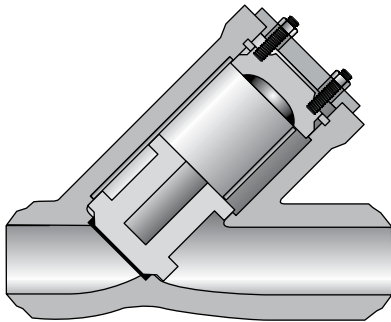

Dim	Description		VALVE SIZES (inches)								
			6	8	10	12	14	16	18	20	24
A	End-to-End Weld Ends	in.	30.00	30.00	36.00	41.00	48.75	48.75	58.00	58.00	68.00
		mm	762	762	914	1041	1238	1238	1473	1473	1727
K	Center-to-Top	in.	24.11	24.11	29.95	34.60	37.33	37.33	47.44	47.44	50.56
		mm.	612	612	761	879	948	95	1205	1205	1284
	Weight Weld Ends	lbs	660	660	1180	1898	3040	3040	4750	4650	7000
		kg	300	300	585	863	1380	1380	2159	2159	3176

VENTURI Y-LIFT-CHECK VALVE

Y-Lift-Check Valve Fig. No. 59625H-7-WE* Butt Weld Ends

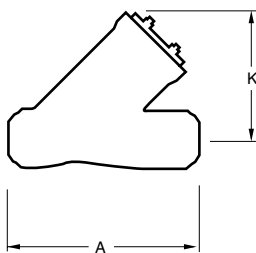

Dim	Description		VALVE SIZES (inches)								
			8x6x8	10x8x10	12x10x12	14x12x14	16x14x16	18x16x18	20x18x20	22x20x22	26x24x26
A	End-to-End Weld Ends	in.	30.00	30.00	36.00	41.00	48.75	48.75	58.00	58.00	68.00
		mm	762	762	914	1041	1238	1238	1473	1473	1727
K	Center-to-Top	in.	24.11	24.11	29.95	34.60	37.33	37.33	47.44	47.44	50.56
		mm	612	612	761	879	948	95	1205	1205	1284
	Weight Weld Ends	lbs	725	725	1310	2110	3375	3375	5275	5272	7770
		kg	329	329	594	959	1530	1530	2398	2392	3525

General Notes:

1. Dimensions, weights, and other engineering data are subject to change or modification. This data is not to be used for construction unless confirmed by Pacific Valves®.
2. For best performance, size for full open operation. See Flow Calculations in the Technical Data Section.
* Specify pipe schedule.
3. Related data available in Technical Data, Actuators, and Accessories sections.



Materials Tilting Disc Check Valves

Tilting Disc Check Valve

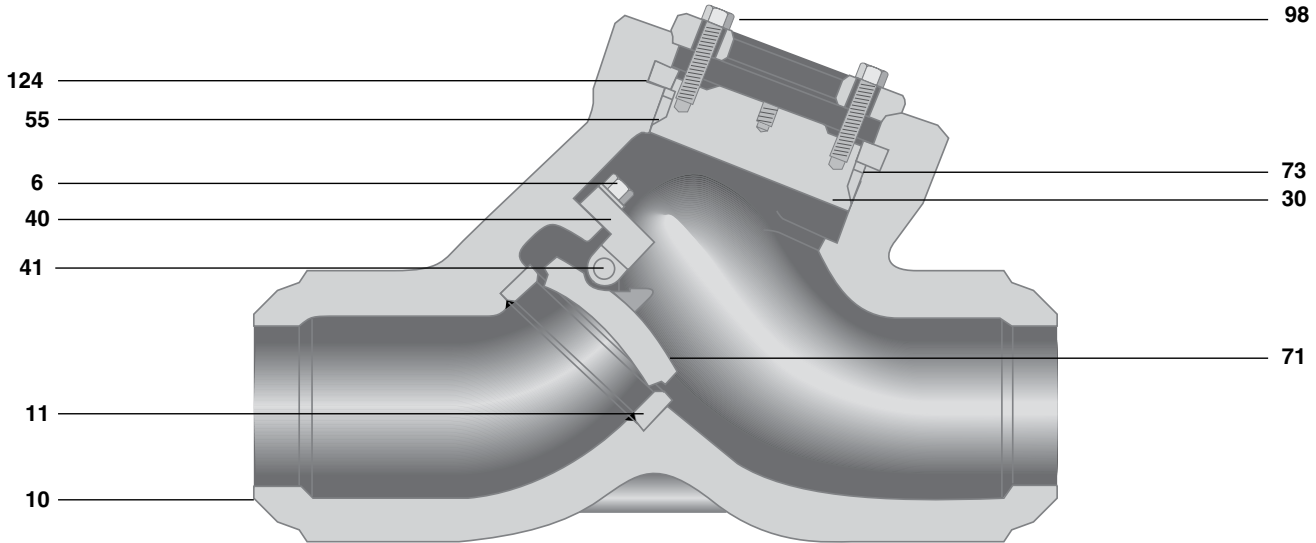

NO	PART NAME	CARBON STEEL	1¼CHROME	2¼ CHROME	9Cr-1Mo-V	316 STAINLESS
30	BONNET CAP	CARBON STEEL	ASTM A182 GR F11/F22	ASTM A182 GR F22	ASTM A182 GRF91	ASTM A182 GR F316
2	BONNET CARRIER	CARBON STEEL	CARBON STEEL	CARBON STEEL	CARBON STEEL	CARBON STEEL
98	BONNET CAP SCREW	ASTM 193 GR B7	ASTM 193 GR B7	ASTM 193 GR B7	ASTM 193 GR B7	ASTM 193 GR B7
73	THRUST RING	AISI 4340 OR 4140	AISI 4340 OR 4140	AISI 4340 OR 4140	AISI 4340 OR 4140	AISI 4340 OR 4140
124	SEGMENT RING	AISI 4340 OR 4140	AISI 4340 OR 4140	AISI 4340 OR 4140	AISI 4340 OR 4140	AISI 4340 OR 4140
6	HINGE CAP SCREW	ASTM 193 GR B7	ASTM 193 GR B7	ASTM 193 GR B7	ASTM 193 GR B7	ASTM 193 GR B8
55	GASKET	GRAPHITE/SS CAPS OR MILD STEEL SILVER PLATED*	GRAPHITE/SS CAPS OR MILD STEEL SILVER PLATED*	GRAPHITE/SS CAPS OR MILD STEEL SILVER PLATED*	GRAPHITE/SS CAPS OR MILD STEEL SILVER PLATED*	GRAPHITE/SS CAPS OR MILD STEEL SILVER PLATED*
40	HINGE	ASTM A351 GR CA-15	ASTM A351 GR CA-15	ASTM A351 GR CA-15	ASTM A351 GR CA-15	ASTM A351 GR CF8M
41	HINGE PIN	ASTM A582 GR 416	ASTM A582 GR 416	ASTM A582 GR 416	ASTM A582 GR 416	ASTM A705 GR 630
11	SEAT RING	CARBON STEEL	316 SS OR 2¼ CR	316 SS OR 2¼ CR	ALLOY 91	316L SS
71	DISC	W/CO-CR OVERLAY ASTM A216 GR WCB	W/CO-CR OVERLAY ASTM A217 GR WC6	W/CO-CR OVERLAY ASTM A217 GR WC9	W/CO-CR OVERLAY ASTM A351 GR 8M	W/CO-CR OVERLAY ASTM A351 GR CF8MW
10	BODY	ASTM A216 GR WCC ³	ASTM A217 GR WC6 ²	ASTM A217 GR WC9 ²	ASTM A217 GR C12A	ASTM A351 GR CF8M
118	SHIM	316SS	316SS	316SS	316SS	316SS
126	LOCKING DEVICE	316SS	316SS	316SS	316SS	316SS

Pacific Valves® reserves the right to change or modify product design or construction without prior notice and without incurring any obligation to make such changes and modifications on products previously or subsequently sold.

- NOTES:**
1. Body material for weld end valves will be ASTM A351 GR CF3M (316L).
 2. A 309 SS inlay is standard in the gasket area of the body on ASME class 2500 valves. For this option on other pressure classes, specify special features suffix H.
 3. WCC valve bonnets and internals will be manufactured with 300 series SS and/or 2¼ CR.

*Graphite Pressure Seal Bonnet Gasket standard. Mild Steel Silver Plated available on request.



Dimensions Tilting Disc Check Valves • ASME Class 900

Fig. No. **58809-7-WE*** Butt Weld Ends
 Fig. No. **58809-7** Flanged, Raised Face
 Fig. No. **58809-7-RJ** Flanged, Ring Joint

Dim	Description		VALVE SIZES (inches)												
			2	2.5	3	4	6	8	10	12	14	16	18	20	24
A	End-to-End Weld Ends	in.	10	10	12	14	20	26	31	36	39	43	48	52	61
		mm	254	254	304	355	508	660	787	914	990	1092	1219	1320	1549
A1	Face-to-Face Flanged Ends	in.	N/A	N/A	15	18	24	19	33	38	40.5	44.5	48	52	61
		mm	N/A	N/A	381	457	609	736	838	965	1028	1130	1219	1320	1549
A2	Face-to-Face RTJ	in.	N/A	N/A	15.13	18.13	24.13	29.13	33.13	38.13	40.88	44.88	48.5	52.5	61.75
		mm	N/A	N/A	384	460	612	739	841	968	1039	1140	1232	1333	1568
K	Center-to-Top	in.	7.5	7.5	7.5	7.5	9.5	12	15	16.5	18	19.75	23.5	26	31
		mm	190	190	190	190	241	304	381	419	457	501	596	660	787
	Weight Weld Ends	lbs	45	45	45	50	130	240	470	720	900	1300	1840	2430	4200
		kg	20	20	20	23	59	109	213	326	408	589	834	1102	1905
	Weight Flange Ends	lbs	N/A	N/A	110	150	350	610	1000	1460	2000	2600	3650	4725	8400
		kg	N/A	N/A	50	68	159	276	473	662	907	1179	1655	2143	3809

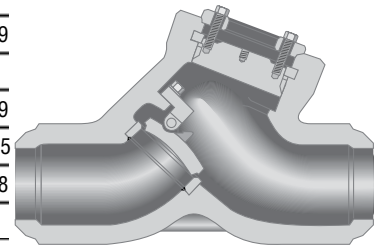

VENTURI TILTING DISC CHECK VALVES

Fig. No. **58809-7-WE*** Butt Weld Ends

Dim	Description		VALVE SIZES (inches)						
			8x6x8	10x8x10	12x10x12	14x12x14	16x14x16	18x16x18	20x18x20
A	End-to-End	in.	24	29	33	38	40.5	44.5	48
		mm	609	736	838	965	1028	1130	1219
K	Center-to-Top Open	in.	9.5	12	15	16.5	18	19.75	23.5
		mm	241	304	381	419	457	501	596
	Weight	lbs	140	250	485	740	930	1350	1890
		kg	63	113	219	335	421	612	857

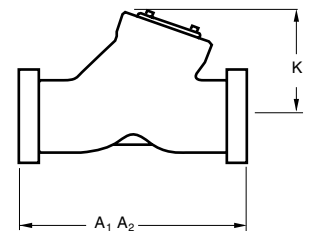
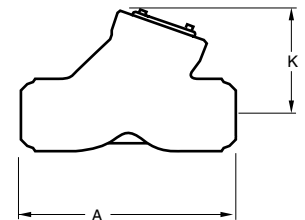

General Notes:

- Dimensions, weights, and other engineering data are subject to change or modification. This data is not to be used for construction unless confirmed by Pacific Valves®.
- For best performance, size for full open operation. See Flow Calculations in the Technical Data Section.
* Specify pipe schedule.
- Related data available in Technical Data, Actuators, and Accessories sections.



Dimensions Tilting Disc Check Valves • ASME Class 1500

Fig. No. **58815-7-WE*** Butt Weld Ends
 Fig. No. **58815-7** Flanged, Raised Face
 Fig. No. **58815-7-RJ** Flanged, Ring Joint

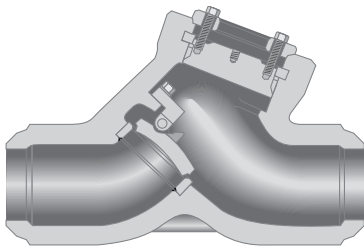

Dim	Description	VALVE SIZES (inches)													
		2	2.5	3	4	6	8	10	12	14	16	18	20	24	
A	End-to-End Weld Ends	in.	12	12	12	16	22	28	34	39	42	47	52	56	66
		mm	254	254	304	406	558	711	863	990	1066	1193	1320	1422	1676
A1	Face-to-Face Flanged Ends	in.	18.5	18.5	18.5	21.5	27.75	32.75	39	44.5	49.5	54.5	60.5	65.5	76.5
		mm	469	469	469	546	704	831	990	1130	1257	1384	1536	1663	1943
A2	Face-to-Face RTJ	in.	18.63	18.63	18.63	21.63	28	33.13	39.38	45.13	50.25	55.38	61.38	66.38	77.63
		mm	473	473	473	549	711	841	1000	1146	1276	1406	1559	1686	1972
K	Center-to-Top	in.	7.5	7.5	7.5	8.5	10.5	13.5	16.5	18.5	20	22	26	29	34.5
		mm	196	196	196	215	266	342	419	469	508	558	660	736	876
	Weight Weld Ends	lbs	55	55	55	80	200	400	720	1100	1380	1980	2790	3700	6370
		kg	25	25	25	36	91	182	326	499	625	857	1265	1678	2888
	Weight Flanged Ends	lbs	150	150	150	220	520	935	1600	2400	3046	4840	6120	8200	12540
		kg	68	68	68	99	235	424	725	1088	1381	2195	2775	3718	5687

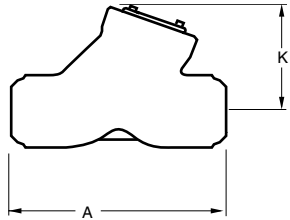

VENTURI TILTING DISC CHECK VALVES

Fig. No. **58815-7-WE*** Butt Weld Ends

Dim	Description	VALVE SIZES (inches)							
		8x6x8	10x8x10	12x10x12	14x12x14	16x14x16	18x16x18	20x18x20	
A	End-to-End	in.	27.75	32.75	39	44.5	49.5	54.5	60.5
		mm	705	831	990	1130	1257	1384	1536
K	Center-to-Top Open	in.	10.5	13.5	16.5	18.5	20	22	26
		mm	266	342	419	469	508	558	660
	Weight	lbs	220	430	750	1140	1425	2030	2840
		kg	99	195	340	517	646	920	1287

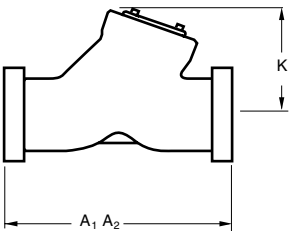

General Notes:

- Dimensions, weights, and other engineering data are subject to change or modification. This data is not to be used for construction unless confirmed by Pacific Valves®.
- For best performance, size for full open operation. See Flow Calculations in the Technical Data Section.
* Specify pipe schedule.
- Related data available in Technical Data, Actuators, and Accessories sections.



Dimensions Tilting Disc Check Valves • ASME Class 2500

Fig. No. **58825H-7-WE*** Butt Weld Ends
 Fig. No. **58825H-7** Flanged, Raised Face
 Fig. No. **58825H-7-RJ** Flanged, Ring Joint

Dim	Description		VALVE SIZES (inches)												
			2	2.5	3	4	6	8	10	12	14	16	18	20	24
A	End-to-End Weld Ends	in.	13	13	14.5	18	24	30	36	41	44	48	53	57	66
		mm	330	330	368	457	610	762	914	1041	1117	1219	1346	1447	1676
K	Center-to-Top	in.	8	8	8	12	13	16	18	21	23	26	28	31	36
		mm	203	203	203	304	330	406	457	533	584	660	711	787	914
	Weight Weld Ends	lbs	80	80	80	110	320	620	1150	1600	2150	2750	3500	4250	6000
		kg	36	36	36	50	145	281	520	725	975	1247	1587	1927	2721
	Weight Flanged Ends	lbs	250	250	250	350	980	1530	3150	4560	4900	5700	6300	7200	9000
		kg	113	113	113	159	445	694	1429	2068	2227	2590	2864	3272	4091

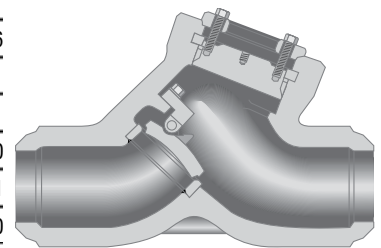

NOTE:

1. For flanged end data on 14"- 24" — contact Pacific Valves®.

VENTURI TILTING DISC CHECK VALVES

Fig. No. **58825H-7-WE*** Butt Weld Ends

Dim	Description		VALVE SIZES (inches)						
			8x6x8	10x8x10	12x10x12	14x12x14	16x14x16	18x16x18	20x18x20
A	End-to-End	in.	28	34	39.75	41	44	49	59.5
		mm	711	863	1009	1041	1117	1244	1511
K	Center-to-Top Open	in.	13	16	18	21	23	26	28
		mm	330	406	457	533	584	660	711
	Weight	lbs	340	640	1200	1660	2230	2850	4300
		kg	154	290	544	752	1011	1292	1950

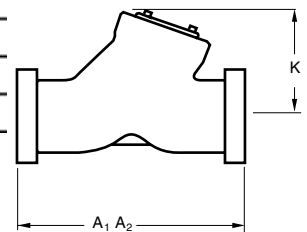
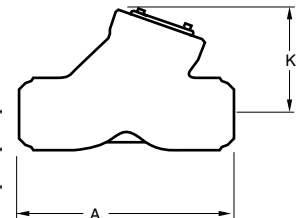

General Notes:

1. Dimensions, weights, and other engineering data are subject to change or modification. This data is not to be used for construction unless confirmed by Pacific Valves®.
2. For best performance, size for full open operation. See Flow Calculations in the Technical Data Section.
* Specify pipe schedule.
3. Related data available in Technical Data, Actuators, and Accessories sections.



Dimensions and Weight **Swing Check Valves**

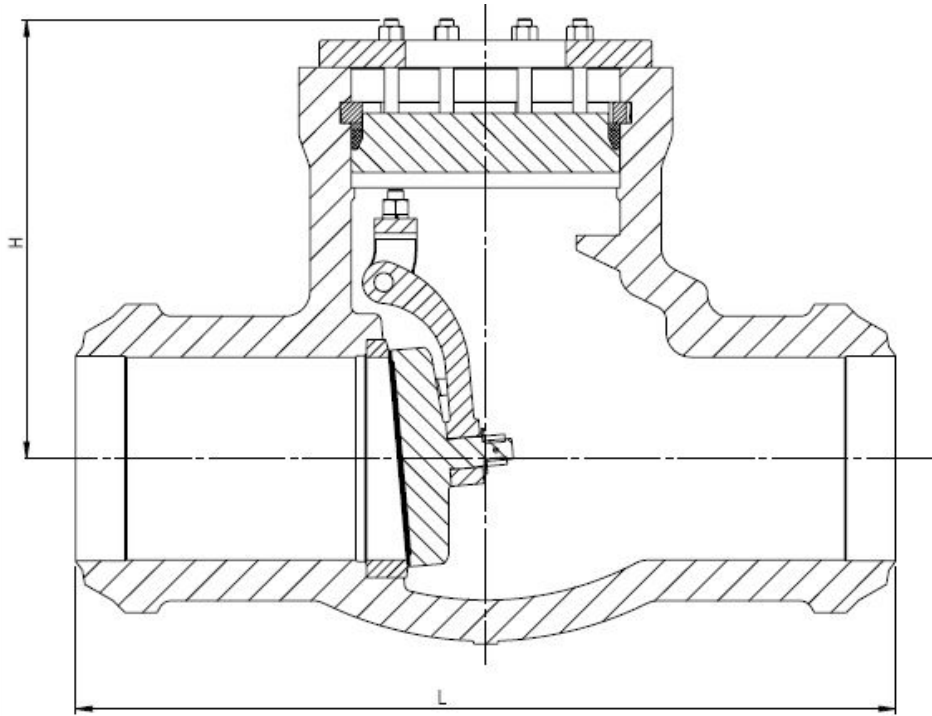

"Valve Size (in)"	Class 900			Class 1500			Class 2500		
	L (in)	H (in)	Weight (lbs.)	L (in)	H (in)	Weight (lbs.)	L (in)	H (in)	Weight (lbs.)
3	12	10.1	76	12	10.1	97	14.5	12	190
4	18	11	119	16	10.7	143	18	12.8	253
6	20	15.2	303	22	15.4	421	24	17.7	722
8	26	18	535	28	18.2	730	30	21.5	1317
10	31	19.8	836	34	20.8	1182	36	24.1	2000
12	36	22.6	1293	39	23.3	1814	41	27.5	2955
14	39	25	1685	42	25.6	2370	44	29.7	3972
16	43	28	2380	47	29	3377	47	35	5714
18	48	28.5	3087	60.5	32.2	5160	53	38.2	8161
20	52	30.6	3866	65.5	35.2	6725	58	41.2	10304
24	62	34.9	6403	76.5	40.4	10966	67	47.4	16450

NOTE:
 L: End to End Dimension
 H: Distance from Valve center to valve cap high point
 Non-standard End to End Dimension



Materials of Construction Swing Check Valves

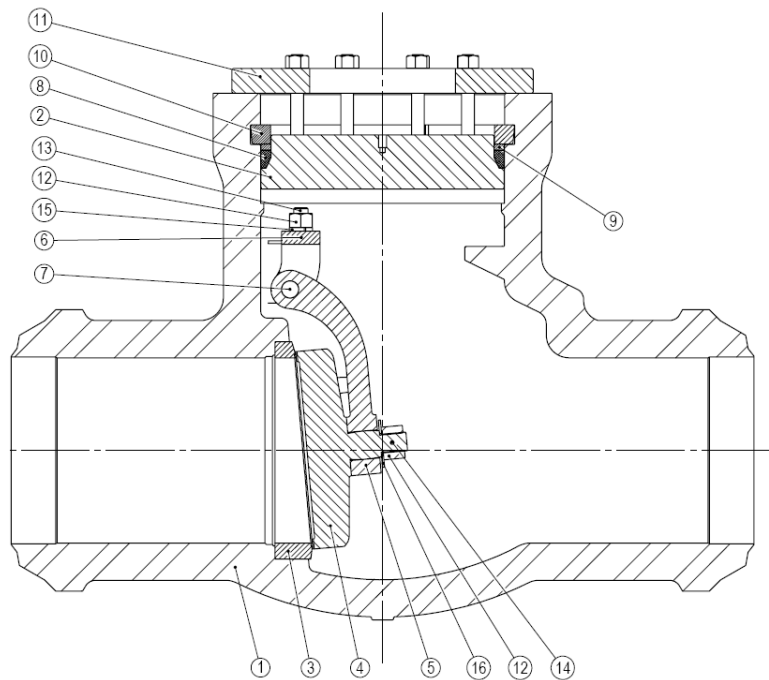

Item No.	Description	ASTM A216 WCB	ASTM A217 WCC	ASTM A217 WC6	ASTM A217 WC9	ASTM A217 C12A	ASTM A351 CF8C
1	Body	ASTM A216 WCB	ASTM A216 WCC	ASTM A217 WC6	ASTM A217 WC9	ASTM A217 C12A	ASTM A351 CF8C
2	Bonnet	ASTM A105	ASTM A182 F11	ASTM A182 F11	ASTM A182 F22	ASTM A182 F91	ASTM A182 F347
3	Seat Ring	ASTM A105 W/ HF	ASTM A182 F11 W/HF	ASTM A182 F11 W/HF	ASTM A182 F22 W/HF	ASTM A182 F91 W/HF	ASTM A182 F347 W/HF
4	Disc	ASTM A105 W/ HF	ASTM A182 F11 W/HF	ASTM A182 F11 W/HF	ASTM A182 F22 W/HF	ASTM A182 F91 W/HF	ASTM A182 F347 W/HF
5	Hinge	A515 70	ASTM A387 11 CL2	ASTM A387 11 CL2	ASTM A387 22 CL2	ASTM A182 F91	ASTM A240 347
6	Hinge Bracket	A515 70	ASTM A387 11 CL2	ASTM A387 11 CL2	ASTM A387 22 CL2	ASTM A182 F91	ASTM A240 347
7	Hinge Pin	ASTM A276 410	ASTM A276 410	ASTM A276 410	ASTM A276 410	STAINLESS STEEL	ASTM A705 630
8	Gasket	Graphite w/ SS Caps	Graphite w/ SS Caps	Graphite w/ SS Caps	Graphite w/ SS Caps	Graphite w/ SS Caps	Graphite w/ SS Caps
9	Thrust Ring	AISI 4340 or 4140	AISI 4340 or 4140	AISI 4340 or 4140	AISI 4340 or 4140	AISI 4340 or 4140	AISI 4340 or 4140
10	Segment Ring	AISI 4340 or 4140	AISI 4340 or 4140	AISI 4340 or 4140	AISI 4340 or 4140	AISI 4340 or 4140	AISI 4340 or 4140
11	Bonnet Carrier	A515 70	A515 70	A515 70	A515 70	A515 70	A515 70
12	Nuts	ASTM A194 Gr 2H	ASTM A194 Gr 2H	ASTM A194 Gr 2H	ASTM A194 Gr 2H	ASTM A194 Gr 2H	ASTM A194 Gr 2H
13	Studs	ASTM A193 B7	ASTM A193 B7	ASTM A193 B7	ASTM A193 B7	ASTM A193 B7	ASTM A193 B7
14	Split Pin	Steel	Steel	Steel	Steel	Steel	Steel
15	Spring Washer	Steel	Steel	Steel	Steel	Steel	Steel
16	Disc Washer	Steel	Steel	Steel	Steel	Steel	Steel

Pacific Valves® reserves the right to change or modify product design or construction without prior notice and without incurring any obligation to make such changes and modifications on products previously or subsequently sold.

NOTES:

1. Body material for weld end valves will be ASTM A351 GR CF3M (316L).
2. A 309 SS inlay is standard in the gasket area of the body on ASME class 2500 valves. For this option on other pressure classes, specify special features suffix H.
3. WCC valve bonnets and internals will be manufactured with 300 series SS and/or 2¼ CR.

*Graphite Pressure Seal Bonnet Gasket standard. Mild Steel Silver Plated available on request.



Pressure Seal Figure Number System

1 2 - 4 5 6 7 8 - 10 11 12 13 - 15 - 17 - 19 20 21 - 23 24 25 26 27 28 29 30

1 - 2 = Size of Connection

2H = 2 1/2" Valve
03 = 3" Valve

4 - 6 = Valve Type

554 = Parallel Disc
555 = Flex Wedge
560 = T-Globe Stop
565 = T-Globe Stop Check (non-return)
580 = Swing Check
586 = Lift Check - Globe
588 = Tilting Disc Check
590 = Y Globe Stop Valve
595 = Y Globe Stop Check
596 = Y Globe Life Check

7 - 8 = Pressure Class

06 = 600
6C = 600 Intermediate Class
(see sales order notes)
09 = 900
9C = 900 Intermediate Class
(see sales order notes)
15 = 1500
1C = 1500 Intermediate Class
(see sales order notes)
25 = 2500
2C = 2500 Intermediate Class
(see sales order notes)
45 = 4500

10 = Valve Port Size

*S = Standard port
R = Reduced port
E = Expanded port

11 - 12 = By Pass, Drain & Bleed Arrangements

* NN = N.A.
EA = Equalizing Line from body neck to A
EB = Equalizing Line from body neck to B
KW = Bonnet Vent in upstream side of wedge
J1 = Single valve bypass from A to B
J2 = Double valve bypass from A to B
J3 = Triple valve bypass from A to B and body neck
JA = Single valve equalizing line from body neck to A
JB = Single valve equalizing line from body neck to B
VV = 6" socket weld nipples with globe style drain valves at locations C&D
PP = 6" socket weld nipples capped at locations C&D
V? = 6" socket weld nipple with globe style drain valve at location? (A-G)
P? = 6" socket weld nipple capped at location? (A-G)

13 = Custom Feature

*N = N.A.
X = See sales order notes

15 = Special Processing

*S = No special processing
Z = See sales order notes

17 = Body Material

1 = WCB
2 = WCC
4 = C12A
5 = C5
6 = WCG
9 = WCG

19 = Customer Pipe Schedule

A = 10
B = 20
C = 30
D = 40
E = STD
F = 60
G = 80
H = XS
J = 100
K = 120
L = 140
M = 160
N = XXS
X = Custom (see sales order notes)

20 - 21 = Valve Weld End Prep Figure (per ASME B16.25)

Pipe wall thickness .1875" to .88"
*2B = For use with no backing ring or split rectangular backing ring
2C = For use with continuous rectangular backing ring
2D = For use with continuous tapered backing ring

Pipe wall thickness greater than .88"
*3B = For use with no backing ring or split rectangular backing ring
3C = For use with continuous rectangular backing ring
3D = For use with continuous tapered backing ring

For use with GTAW root pass or consumable insert ring
5B = Pipe wall thickness from .38" to 1.0"
6B = Pipe wall thickness over 1.0"

XX= Custom weld ends (see sales order notes)

RF= Raised face flanged end connections

23 = Manual Operation

N = N.A.
H = Handwheel
L = Handwheel with locking device (closed)
R = Handwheel with locking device (open)
J = Handwheel with chain
G = Manual Bevel Gear Operator
C = Manual Bevel Gear Operator with Chainwheel
A = Manual Bevel Gear with Air Wrench
P = Manual Bevel Gear with position indicator
M = Manual Bevel Gear Operator with locking device (closed)
R = Manual Bevel Gear Operator with locking device (open)
B = Hammerblow Handwheel

24 = Valve Actuator

N = N.A.
E = Direct mount Electric Motor Operator
T = Direct mount Electric Motor Operator with thermal compensating device
F = Electric Motor Operator with Bevel Gear
P = Pneumatic Operator
H = Hydraulic Operator
M = Operator mounted by customer

25 = Gear & Actuator Mounting Dimensions (per MSS SP-102)

N = N.A. 5 = FA25
1 = FA7 6 = FA30
2 = FA10 7 = FA35
3 = FA14 8 = FA40
4 = FA16 9 = Other

* Denotes Standard Offering



Notes



Crane ChemPharma & Energy

Crane Energy Headquarters
4526 Research Forest Drive, Suite 400
The Woodlands, Texas 77381 U.S.A
Tel: +1 936 271 6500
Fax +1 936 271 6510

www.cranecpe.com



Pacific Valves Customer Service
88/1A Vadugapatti Villiage
Viralimamiai 621316 India
Tel.: +91-4339-220252
Fax.: +91-4339-220013

Pacific Valves Customer Service
3201 Walnut Avenue
Signal Hill, CA 90755 U.S.A
Tel: +1 562 426 2531
Fax +1 562 595 9717

brands you trust.



COMPAC-NOZ®



DEPA®

ELRO®

DUO-CHEK®



NOZ-CHEK®



RESISTOFLEX®



Saunders®
the science inside

STOCKHAM®



UNI-CHEK®

w.ta®

XOMOX®

Crane Co., and its subsidiaries cannot accept responsibility for possible errors in catalogues, brochures, other printed materials, and website information. Crane Co. reserves the right to alter its products without notice, including products already on order provided that such alteration can be made without changes being necessary in specifications already agreed. All trademarks in this material are property of the Crane Co. or its subsidiaries. The Crane and Crane brands logotype, in alphabetical order, (ALOYCO®, CENTER LINE®, COMPAC-NOZ®, CRANE®, DEPA®, DUO-CHEK®, ELRO®, FLOWSEAL®, JENKINS®, KROMBACH®, NOZ-CHEK®, PACIFIC VALVES®, RESISTOFLEX®, REVO®, SAUNDERS®, STOCKHAM®, TRIANGLE®, UNI-CHEK®, WTA®, and XOMOX®) are registered trademarks of Crane Co. All rights reserved.