

# NOZ-CHEK<sup>®</sup>



RELIABLE BACK-FLOW PREVENTION AND ENGINEERED PERFORMANCE  
FOR THE MOST CRITICAL APPLICATIONS

**NOZ-CHEK<sup>®</sup>**  
High Performance Nozzle-Type  
Non-Slam Check Valve

**CRANE**<sup>®</sup>

**v in** [www.cranecpe.com](http://www.cranecpe.com)

## NOZ-CHEK® Non-Slam Check Valve

### SCOPE OF SUPPLY

- Sizes ¾"– 84"
- ASME B16.34 & API 6D, pressure classes 150 – 4500
- API 6A pressure ratings 2000 – 15,000
- Flanged, butt-weld ends, hubs ends and specials
- API 6D or Manufacturer's Standard face to face
- Wide range of materials of construction available, consult factory for special application requirements

### STANDARD FEATURES

#### 1. Extensive research and development, coupled with robust design validation has resulted in industry leading features:

- **Few moving parts** - Disc is the only moving part, minimizing wear.
- **Axial movement of disc** - Disc and seating configuration give streamlined flow path, resulting in low pressure loss.
- **Short stroke of spring-assisted disc** - Inlet flow velocity moves disc axially with short stroke. In response to flow velocity reduction, a compressed spring initiates valve closure and provides quick response.
- **Spring options** - Choice of spring affects critical velocity and valve response. Selection is made on engineering evaluation of specific applications. In absence of this data, a standard spring will be provided.

### CHARACTERISTICS

NOZ-CHEK® valves deliver an effective dynamic response under various flow deceleration conditions. The dynamic performance characteristics of NOZ-CHEK® valves are compared to swing check and dual plate spring-assisted check valves in Figure 1.

NOZ-CHEK®'s design features result in superior performance, fast response and lower pressure loss in piping systems.

### OPENING

When the valve begins to open an increase in kinetic pressure, generated by increased velocity in the reduced flow area, assists the disc to open and permits extra spring loading that facilitates fast closure.

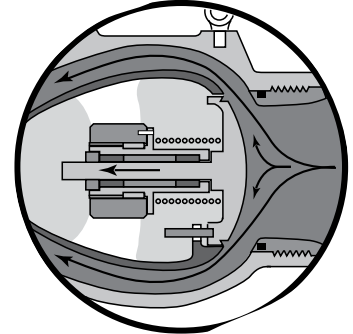

The spring force is exceeded in the fully open position.

The NOZ-CHEK® geometry permits full opening from relatively low flows to ensure that the disc is stabilized against its stop even if moderate flow oscillation occurs.

### CLOSING

When the flow drops below the critical velocity, the disc will begin to close. Selecting the correct spring limits backflow and water hammer.

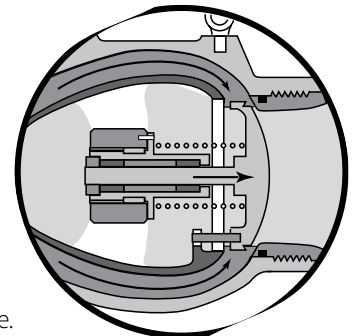

The spring load, low mass disc, and short displacement ensures a rapid self-dampening response.

For certain applications, the internal geometry can be modified to suit the service conditions.

Figure 1

## NOZ-CHEK® Capabilities, Features & Benefits

### HIGH PERFORMANCE NON-SLAM CHECK VALVE

One of the most significant elements of piping system design is integrating the means to protect mechanical equipment and prevent damage caused by backflow. Backflow prevention is routinely achieved through the use of swing check valves or dual-plate check valves.

NOZ-CHEK® valves are specifically designed for fast-reversing systems where backflow is a constant concern. In such critical service applications, NOZ-CHEK® Non-Slam Check Valves offer the following benefits.

- **Minimizes the damaging effects of water hammer in fluid systems**
- **Removal of chatter associated with conventional valves in reciprocating compressor service**
- **Protects rotating equipment from damage due to flow reversal**
- **Minimizes pressure loss in piping systems**
- **Provides quick dynamic response reducing reverse velocity**

### LOW CRYOGENIC LEAK RATE PER BS 6364 INDUSTRY STANDARD

NOZ-CHEK® valves meet the standard requirements of ASME B16.34, API 6D and API 598. Now, with expansion of this product line, the NOZ-CHEK® Cryogenic valve can meet the rigorous requirements of BS 6364 (300 cc/min/in at -196°C/ -320°F), Shell 77/200, MSS SP-134, ISO 28921-1.

### ZERO FUGITIVE EMISSIONS

NOZ-CHEK® products feature a single piece solid body (no penetrations or external leak paths), reflecting our commitment to environmental responsibility and critically ensuring zero fugitive emissions.

### IN-HOUSE CRYOGENIC TESTING

The low temperature and Cryogenic High-Pressure gas testing is carried out on-site in our state of the art testing facilities. Test capability 1" to 72" and test pressures of 22,500 PSI.

### INNOVATION OF PROVEN TECHNOLOGY

Dedication to solving our Customers' challenges, longstanding commitment to safety and quality continue to drive our product innovation.

| Industry Standards, Specifications and Directives* |  |
|--|--|
| API 598  | Valve Pressure Testing and Inspection                  |
| ASME B16.34  | Pressure/Temperature Ratings                           |
| API 6D   | Pipeline Valves  |
| API 6A   | Specification for Wellhead and Tree Equipment          |
| 2014/68/EU   | Pressure Equipment Directive                           |
| ISO 28921 – 1                                      | International Standards Organisation Cryogenic testing |
| BS 6364  | British Standard Cryogenic testing                     |
| MSS SP-134   | Manufacturing Standards Society Cryogenic testing      |

\*Consult factory for other specification requirements.



### Oil and Gas Production

- Centrifugal Compressor Discharge
- Fire Water Lines
- Oil/Steam Separation
- Steam and CO<sub>2</sub> Injection
- Gas/Oil Gathering Systems
- Flowlines
- Wellheads
- Regasification
- Liquidfaction

### Power Generation

- Steam
- Condensate
- Boiler Feed Pumps
- Cooling Towers
- Service Water Recirculators
- River Water Intake
- Nuclear Energy

### Petroleum Refining

- Hydrogen
- Cracking
- Steam
- Crude Oil
- Gasoline
- Visbreakers
- Naphtha
- Sulfur

### Petrochemicals

- Ethylene
- Propylene
- Steam
- Reboilers
- Gases
- EO/EG

### Chemicals

- Chlorine
- Phosgene
- Aromatics
- Polymers
- Acids
- Air Separation
- Caustics

### Water and Wastewater

- Distribution Lines
- Pumping Stations
- Sewage Plant Blower Discharge
- Chemical Treatment
- Fire Protection Systems
- HVAC Systems
- Desalination

### Steel/Primary Metals

- Quench Lines
- De-Scaling
- Continuous Casters
- Steam
- Condensate
- Strippers
- Electro-Galvanizing

### Pulp and Paper

- Bleaching Lines
- Black Liquor
- Green Liquor
- White Water
- Steam
- Chemical Recovery

### Marine

- FPSO
- Oil Tankers
- Tanker Loading Terminals
- Offshore Platforms
- Sub-Sea Manifolds
- Terminal Transfer Lines
- Barge Unloading Lines
- Shipboard Services

### Renewables

- Solar Power
- Wave Power
- Green Hydrogen
- Carbon Capture

### Gas Transmission

- Compressor Suction/Discharge/Bypass

### Typical Cryogenic Applications

- LNG
- Liquefaction Compression Train
- Mixed Refrigerant
- Ethylene Production
- Ethylene Refrigeration
- Air Separation Units
- General Cryogenic compressor protection

## NOZ-CHEK® Design Features NC / NCS / NCV

### 1 DISC

Standard disc is high strength with minimized weight to provide fast dynamic response. Design minimizes bearing loads, thus lengthens life of bearings and shaft. Offered in a variety of trim materials, with metal or resilient seating.

### 2 FLOW OUTLET ZONE

Geometry controls the flow path to minimize pressure loss.

### 3 SEAT

Provides seating surface for disc and enables bubble-tight seal with resilient materials.

### 4 FLOW INLET ZONE

Venturi effect maximizes flow impact on disc. Provides streamlined flow when valve is fully open to minimize pressure loss.

### 5 SPRING

Each valve is designed with a bespoke spring to best meet the specific customer service conditions.

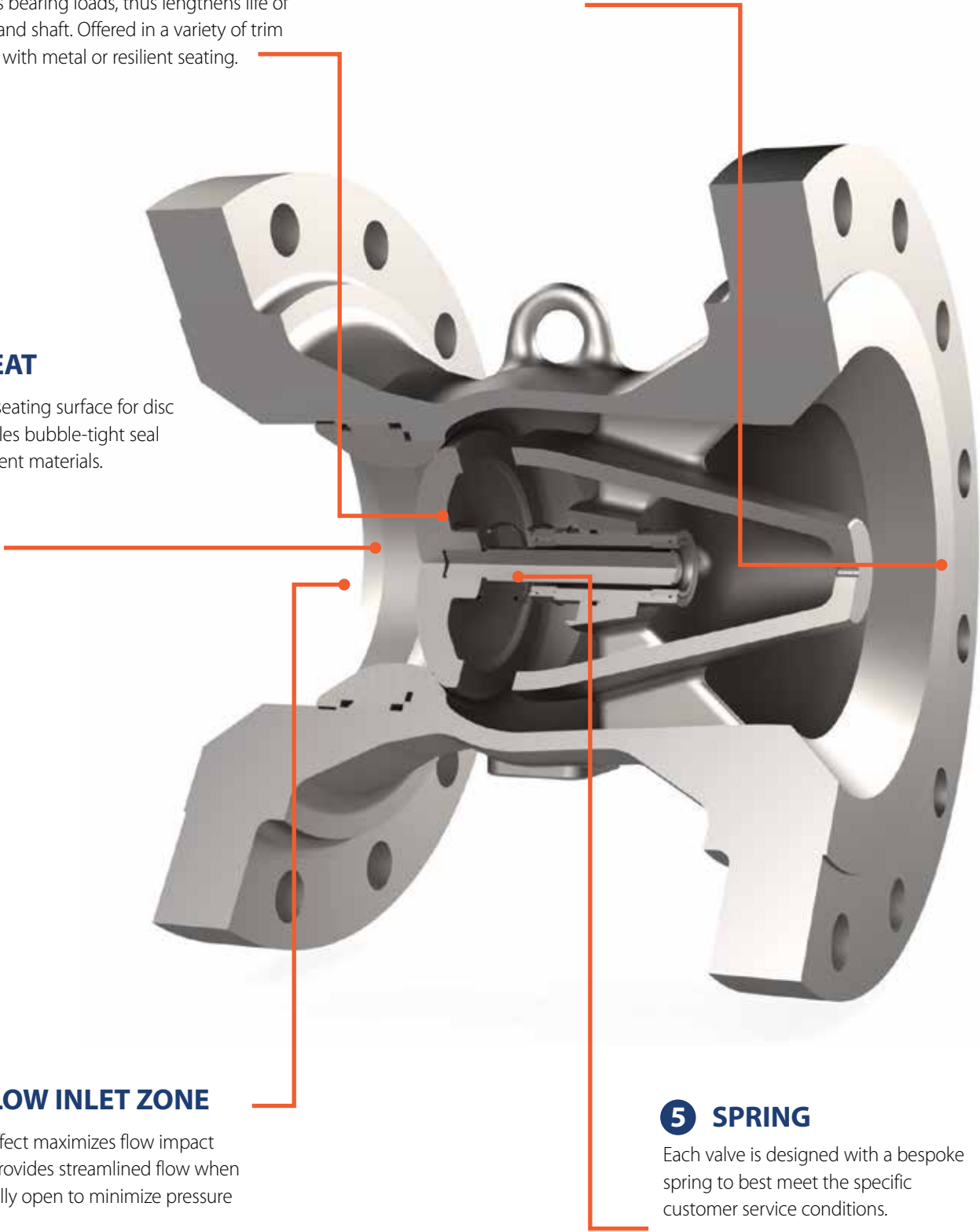

## Flanged End - Dimensional Data NC / NCS / NCV

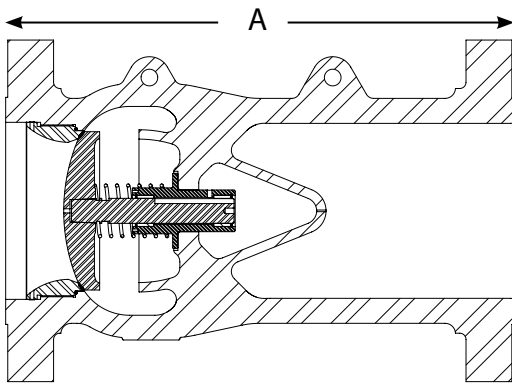

**Style NC**  
API 6D Long Pattern

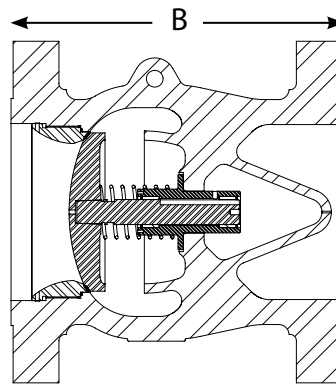

**Style NCS**  
Manufacturer's Standard  
Pattern up to 36"

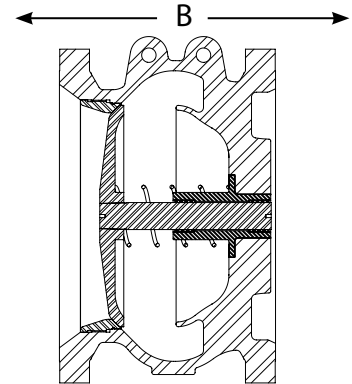

**Style NCV**  
Manufacturer's Standard  
Pattern above 36"

### Class 150 RF

| Nominal Size | API 6D Long Pattern | Mfr Standard Pattern | Weight         |                 |
|--------------|---------------------|----------------------|----------------|-----------------|
|              | A<br>in (mm)        | B<br>in (mm)         | A<br>lbs. (kg) | B<br>lbs. (kg)  |
| 2            | 8.00 (203)          | -                    | 22 (10)        | -               |
| 3            | 9.50 (241)          | -                    | 66 (30)        | -               |
| 4            | 11.50 (292)         | -                    | 106 (48)       | -               |
| 6            | 14.00 (356)         | -                    | 168 (76)       | -               |
| 8            | 19.50 (495)         | -                    | 428 (194)      | -               |
| 10           | 24.50 (622)         | 14.37 (365)          | 536 (243)      | 485 (220)       |
| 12           | 27.50 (699)         | 17.25 (438)          | 628 (285)      | 622 (282)       |
| 14           | 31.00 (787)         | 18.70 (475)          | 944 (428)      | 765 (347)       |
| 16           | 34.00 (864)         | 21.45 (545)          | 1,078 (489)    | 915 (415)       |
| 18           | 38.50 (978)         | 24.00 (610)          | 1,795 (814)    | 1,186 (538)     |
| 20           | 38.50 (978)         | 33.47 (850)          | 3,177 (1,441)  | 2,370 (1,075)   |
| 24           | 51.00 (1,295)       | 31.88 (810)          | 2,540 (1,152)  | 2,888 (1,310)   |
| 28           | 57.00 (1,448)       | 37.22 (945)          | 4,422 (2,006)  | 3,439 (1,560)   |
| 30           | 60.00 (1,524)       | 39.77 (1,010)        | 5,417 (2,457)  | 4,332 (1,965)   |
| 36           | 77.00 (1,956)       | 32.00 (813)          | 5,983 (2,714)  | 5,743 (2,605)   |
| 42           | -                   | 35.00 (889)          | -              | 9,039 (4,100)   |
| 48           | -                   | 38.00 (965)          | -              | 11,629 (5,275)  |
| 54           | -                   | 41.00 (1,041)        | -              | 20,834 (9,450)  |
| 60           | -                   | 45.00 (1,143)        | -              | 23,810 (10,800) |

### Class 300 RF

| Nominal Size | API 6D Long Pattern | Mfr Standard Pattern | Weight         |                 |
|--------------|---------------------|----------------------|----------------|-----------------|
|              | A<br>in (mm)        | B<br>in (mm)         | A<br>lbs. (kg) | B<br>lbs. (kg)  |
| 2            | 10.50 (267)         | -                    | 29 (13)        | -               |
| 3            | 12.50 (318)         | -                    | 66 (30)        | -               |
| 4            | 14.00 (356)         | -                    | 106 (48)       | -               |
| 6            | 17.50 (445)         | 10.00 (254)          | 209 (95)       | 194 (88)        |
| 8            | 21.00 (533)         | 12.25 (311)          | 450 (204)      | 419 (190)       |
| 10           | 24.50 (622)         | 14.37 (365)          | 613 (278)      | 547 (248)       |
| 12           | 28.00 (711)         | 17.25 (438)          | 730 (331)      | 672 (305)       |
| 14           | 33.00 (838)         | 18.70 (475)          | 1,186 (538)    | 981 (445)       |
| 16           | 34.00 (864)         | 21.45 (545)          | 1,426 (647)    | 1,168 (530)     |
| 18           | 38.50 (978)         | 24.00 (610)          | 1,808 (820)    | 1,521 (690)     |
| 20           | 40.00 (1,016)       | 31.88 (810)          | 2,586 (1,173)  | 2,403 (1,090)   |
| 24           | 53.00 (1,346)       | 31.88 (810)          | 3,338 (1,514)  | 3,020 (1,370)   |
| 28           | 59.00 (1,499)       | 40.75 (1,035)        | 5,262 (2,387)  | 4,850 (2,200)   |
| 30           | 62.75 (1,594)       | 39.77 (1,010)        | 5,831 (2,645)  | 5,278 (2,394)   |
| 36           | 82.00 (2,083)       | 32.00 (813)          | 9,608 (4,358)  | 8,091 (3,670)   |
| 42           | -                   | 55.72 (1,415)        | -              | 12,390 (5,620)  |
| 48           | -                   | 38.00 (965)          | -              | 11,740 (5,325)  |
| 54           | -                   | 41.00 (1,041)        | -              | 22,355 (10,140) |
| 60           | -                   | 45.00 (1,143)        | -              | 24,471 (11,100) |

### Class 600 RF

| Nominal Size | API 6D Long Pattern | Mfr Standard Pattern | Weight         |                 |
|--------------|---------------------|----------------------|----------------|-----------------|
|              | A<br>in (mm)        | B<br>in (mm)         | A<br>lbs. (kg) | B<br>lbs. (kg)  |
| 2            | 11.50 (292)         | -                    | 37 (17)        | -               |
| 3            | 14.00 (356)         | -                    | 66 (30)        | -               |
| 4            | 17.00 (432)         | -                    | 163 (74)       | -               |
| 6            | 22.00 (559)         | 15.37 (390)          | 425 (193)      | 373 (169)       |
| 8            | 26.00 (660)         | 12.25 (311)          | 551 (250)      | 448 (203)       |
| 10           | 31.00 (787)         | 14.38 (365)          | 880 (399)      | 739 (335)       |
| 12           | 33.00 (838)         | 17.25 (438)          | 1,138 (516)    | 939 (426)       |
| 14           | 35.00 (889)         | 18.69 (475)          | 1,437 (652)    | 1,186 (538)     |
| 16           | 39.00 (991)         | 21.50 (546)          | 2,110 (957)    | 1,742 (790)     |
| 18           | 43.00 (1,092)       | 31.88 (810)          | 3,411 (1,547)  | 2,987 (1,355)   |
| 20           | 47.00 (1,194)       | 31.88 (810)          | 3,389 (1,537)  | 3,042 (1,380)   |
| 24           | 55.00 (1,397)       | 31.88 (810)          | 5,315 (2,411)  | 4,266 (1,935)   |
| 28           | 63.00 (1,600)       | 34.25 (870)          | 8,673 (3,934)  | 5,864 (2,660)   |
| 30           | 65.00 (1,651)       | 39.75 (1,010)        | 8,675 (3,935)  | 6,614 (3,000)   |
| 36           | 82.00 (2,083)       | 47.82 (1,215)        | 19,354 (8,779) | 9,921 (4,500)   |
| 42           | -                   | 57.50 (1,461)        | -              | 14,515 (6,584)  |
| 48           | -                   | 63.58 (1,615)        | -              | 22,597 (10,250) |
| 54           | -                   | 72.00 (1,829)        | -              | 27,337 (12,400) |
| 60           | -                   | 85.00 (2,159)        | -              | 40,786 (18,500) |

## Flanged End - Dimensional Data NC / NCS / NCV

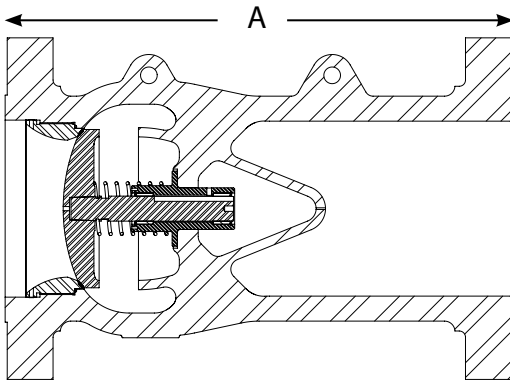

**Style NC**  
API 6D Long Pattern

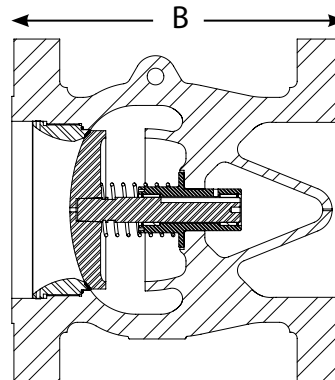

**Style NCS**  
Manufacturer's Standard  
Pattern up to 36"

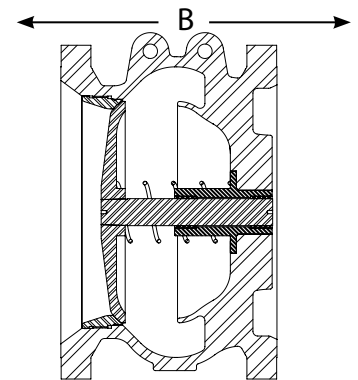

**Style NCV**  
Manufacturer's Standard  
Pattern above 36"

### Class 900 RF

| Nominal Size | API 6D Long Pattern | Mftr Standard Pattern | Weight        |                 |
|--------------|---------------------|-----------------------|---------------|-----------------|
|              | A                   | B                     | A             | B               |
|              | in (mm)             | in (mm)               | lbs. (kg)     | lbs. (kg)       |
| 2            | 14.50 (368)         | -                     | 79 (36)       | -               |
| 3            | 15.00 (381)         | -                     | 121 (55)      | -               |
| 4            | 18.00 (457)         | -                     | 220 (100)     | -               |
| 6            | 24.00 (610)         | 15.38 (391)           | 567 (257)     | 425 (193)       |
| 8            | 29.00 (737)         | 13.63 (346)           | 739 (335)     | 639 (290)       |
| 10           | 33.00 (838)         | 15.50 (394)           | 1,508 (684)   | 1,065 (483)     |
| 12           | 38.00 (965)         | 18.00 (457)           | 1,951 (885)   | 1,488 (675)     |
| 14           | 40.50 (1,029)       | 18.62 (473)           | 2,928 (1,328) | 1,532 (695)     |
| 16           | 44.50 (1,130)       | 29.51 (750)           | 3,225 (1,463) | 2,690 (1,220)   |
| 18           | 48.00 (1,219)       | 30.50 (775)           | 4,456 (2,021) | 3,175 (1,440)   |
| 20           | 52.00 (1,321)       | 34.22 (869)           | 6,484 (2,941) | 4,674 (2,120)   |
| 24           | 61.00 (1,549)       | 40.00 (1,016)         | 8,126 (3,686) | 7,015 (3,182)   |
| 28           | -                   | 40.00 (1,016)         | -             | 10,251 (4,650)  |
| 30           | -                   | 40.41 (1,026)         | -             | 10,472 (4,750)  |
| 36           | -                   | 46.84 (1,190)         | -             | 15,984 (7,250)  |
| 42           | -                   | 60.00 (1,524)         | -             | 21,870 (9,920)  |
| 48           | -                   | 64.00 (1,626)         | -             | 31,747 (14,400) |

### Class 1500 RF

| Nominal Size | API 6D Long Pattern | Mftr Standard Pattern | Weight         |                |
|--------------|---------------------|-----------------------|----------------|----------------|
|              | A                   | B                     | A              | B              |
|              | in (mm)             | in (mm)               | lbs. (kg)      | lbs. (kg)      |
| 2            | 14.50 (368)         | -                     | 79 (36)        | -              |
| 3            | 18.50 (470)         | -                     | 172 (78)       | -              |
| 4            | 21.50 (546)         | -                     | 271 (123)      | -              |
| 6            | 27.75 (705)         | 15.88 (403)           | 805 (365)      | 595 (270)      |
| 8            | 32.75 (832)         | 13.63 (346)           | 1,008 (457)    | 805 (365)      |
| 10           | 39.00 (991)         | 15.50 (394)           | 1,978 (897)    | 1,385 (628)    |
| 12           | 44.50 (1,130)       | 18.00 (457)           | 2,650 (1,202)  | 1,984 (900)    |
| 14           | 49.50 (1,257)       | 25.53 (648)           | 4,932 (2,237)  | 3,527 (1,600)  |
| 16           | 54.50 (1,384)       | 29.53 (750)           | 5,485 (2,488)  | 4,057 (1,840)  |
| 18           | 60.50 (1,537)       | 32.00 (813)           | 8,106 (3,677)  | 5,952 (2,700)  |
| 20           | 65.50 (1,664)       | 34.22 (869)           | 9,207 (4,176)  | 6,504 (2,950)  |
| 24           | 76.50 (1,943)       | 34.22 (869)           | 13,329 (6,046) | 11,442 (5,190) |

### Class 2500 RF

| Nominal Size | API 6D Long Pattern | Mftr Standard Pattern | Weight        |               |
|--------------|---------------------|-----------------------|---------------|---------------|
|              | A                   | B                     | A             | B             |
|              | in (mm)             | in (mm)               | lbs. (kg)     | lbs. (kg)     |
| 2            | 17.75 (451)         | -                     | 115 (52)      | -             |
| 3            | 22.75 (578)         | -                     | 262 (119)     | -             |
| 4            | 26.50 (673)         | -                     | 370 (168)     | -             |
| 6            | 36.00 (914)         | 15.88 (403)           | 1,307 (593)   | 1,069 (485)   |
| 8            | 40.25 (1,022)       | 17.69 (449)           | 1,925 (873)   | 1,543 (700)   |
| 10           | 50.00 (1,270)       | 22.13 (562)           | 3,638 (1,650) | 2,705 (1,227) |
| 12           | 56.00 (1,422)       | 36.00 (914)           | 5,604 (2,542) | 4,570 (2,073) |

Note: API 6D now includes a short pattern face to face range which can be offered on request.

## Flanged End Dimensional Data - TC / TCS

### 1 DISC

Standard disc is high strength with minimized weight to provide fast dynamic response. Design minimizes bearing loads, thus lengthens life of bearings and shaft. Offered in a variety of trim materials, with metal or resilient seating.

### 2 FLOW OUTLET ZONE

Geometry controls the flow path to minimize pressure loss.

### 3 INTEGRAL SEAT

Provides seating surface for disc and enables bubble-tight seal with resilient materials.

### 4 FLOW INLET ZONE

Venturi effect maximizes flow impact on disc. Provides streamlined flow when valve is fully open to minimize pressure loss.

### 5 SPRING

Each valve is designed with a bespoke spring to best meet the specific customer service conditions.

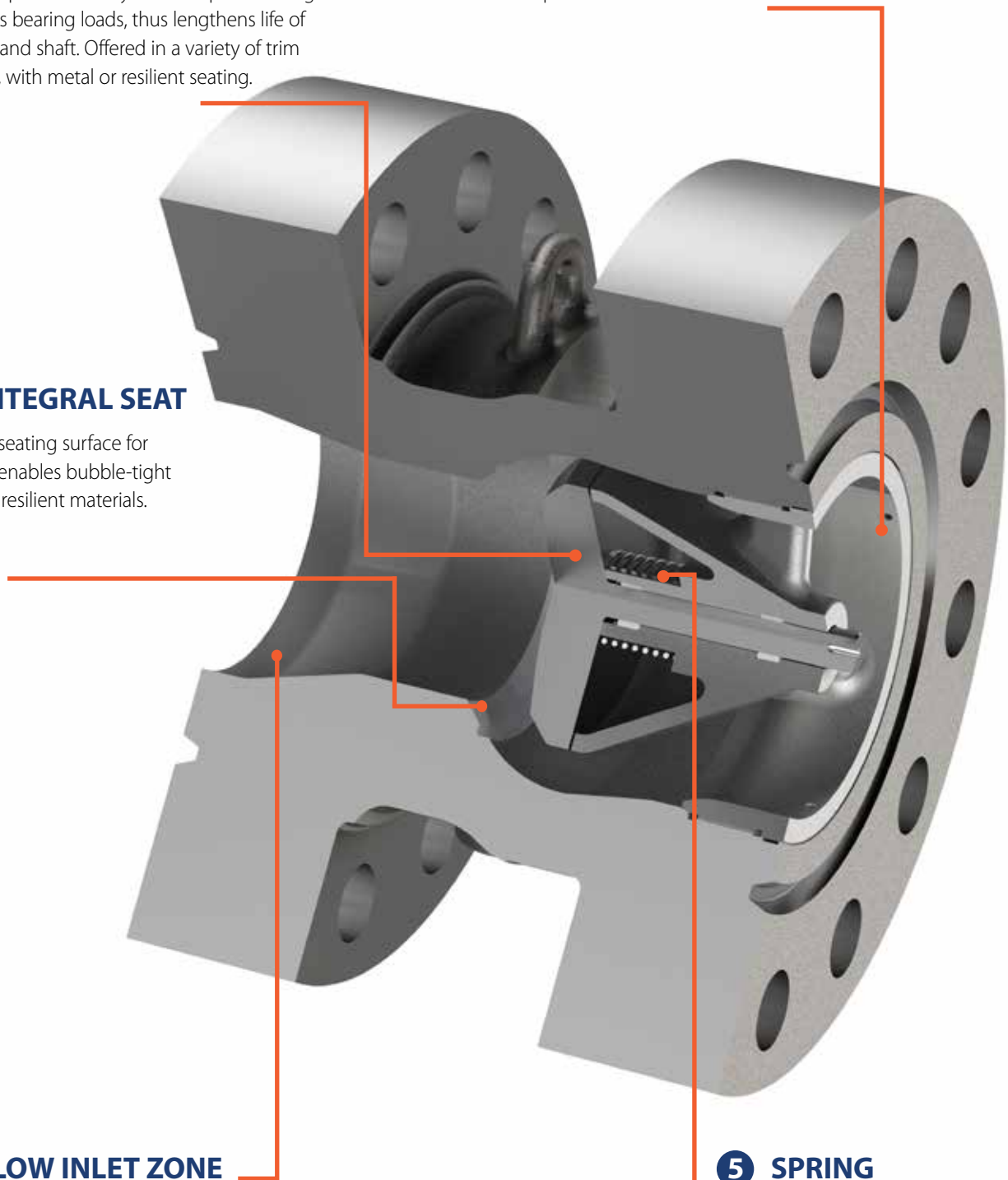



## Flanged End Dimensional Data - TC / TCS

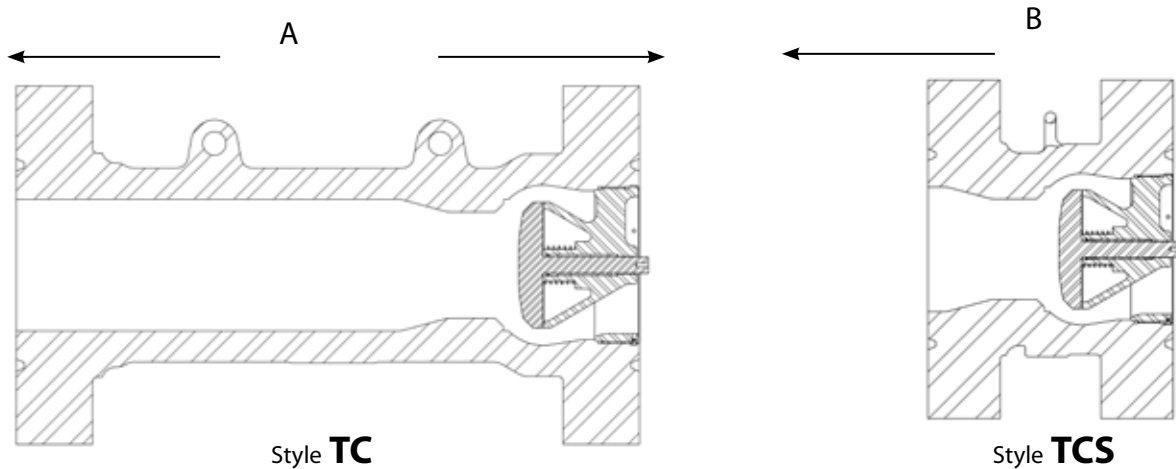

Style **TC**  
API 6D Long Pattern

Style **TCS**  
Manufacturer's Standard  
Pattern up to 36"

### Class **150 RF**

| Nominal Size | API 6D Long Pattern | API 6D Short Pattern | Weight      |             |
|--------------|---------------------|----------------------|-------------|-------------|
|              |                     |                      | A lbs. (kg) | B lbs. (kg) |
|              | A in (mm)           | B in (mm)            |             |             |
| 1            | 5.00 (127)          | -                    | 6.6 (3)     | -           |
| 2            | 8.00 (204)          | -                    | 17.6 (8)    | -           |
| 3            | 9.50 (241)          | -                    | 37.4 (17)   | -           |
| 4            | 11.50 (292)         | -                    | 63.8 (29)   | -           |
| 6            | 14.00 (356)         | 8.27 (210)           | 99 (45)     | 77 (35)     |
| 8            | 19.50 (495)         | 11.02 (280)          | 176 (80)    | 136.4 (62)  |

### Class **300 RF**

| Nominal Size | API 6D Long Pattern | API 6D Short Pattern | Weight       |                |
|--------------|---------------------|----------------------|--------------|----------------|
|              |                     |                      | A lbs. (kg)  | B lbs. (kg)    |
|              | A in (mm)           | B in (mm)            |              |                |
| 1            | 8.50 (216)          | -                    | 10.67 (4.85) | -              |
| 2            | 10.50 (267)         | -                    | 24.64 (11.2) | -              |
| 3            | 12.50 (318)         | -                    | 48.4 (22)    | -              |
| 4            | 14.00 (356)         | -                    | 85.8 (39)    | -              |
| 6            | 17.50 (445)         | 8.27 (210)           | 143.6 (65.3) | 112.88 (51.31) |
| 8            | 21.00 (533)         | 11.02 (280)          | 283.8 (129)  | 212 (96.5)     |

### Class **600 RF**

| Nominal Size | API 6D Long Pattern | API 6D Short Pattern | Weight        |             |
|--------------|---------------------|----------------------|---------------|-------------|
|              |                     |                      | A lbs. (kg)   | B lbs. (kg) |
|              | A in (mm)           | B in (mm)            |               |             |
| 1            | 8.50 (216)          | -                    | 11 (5)        | -           |
| 2            | 11.50 (292)         | -                    | 27.5 (12.5)   | -           |
| 3            | 14.00 (356)         | -                    | 54.34 (24.7)  | -           |
| 4            | 17.00 (432)         | -                    | 112.64 (51.2) | -           |
| 6            | 22.00 (559)         | 8.27 (210)           | 229.9 (104.5) | 169.4 (77)  |
| 8            | 26.00 (660)         | 11.02 (280)          | 393.8 (179)   | 284 (129)   |

\*Note - For other sizes please consult factory.

## Flanged End Non-Slam Dimensional Data - TC / TCS

### Class 900 RF

| Nominal Size | API 6D Long Pattern | API 6D Short Pattern | Weight        |                |
|--------------|---------------------|----------------------|---------------|----------------|
|              |                     |                      | A lbs. (kg)   | B lbs. (kg)    |
|              | A in (mm)           | B in (mm)            |               |                |
| 1            | 10.00 (254)         | -                    | 24.6 (11.2)   | -              |
| 2            | 14.50 (368)         | -                    | 69.08 (31.4)  | -              |
| 3            | 15.00 (381)         | -                    | 102.74 (46.7) | -              |
| 4            | 18.00 (457)         | -                    | 168.96 (76.8) | -              |
| 6            | 24.00 (610)         | 9.06 (230)           | 327.8 (149)   | 239.36 (108.8) |
| 8            | 29.00 (737)         | 11.02 (280)          | 578.6 (263)   | 424.6 (193)    |

### Class 1500 RF

| Nominal Size | API 6D Long Pattern | API 6D Short Pattern | Weight         |                |
|--------------|---------------------|----------------------|----------------|----------------|
|              |                     |                      | A lbs. (kg)    | B lbs. (kg)    |
|              | A in (mm)           | B in (mm)            |                |                |
| 1            | 10.00 (254)         | -                    | 24.6 (11.2)    | -              |
| 2            | 14.50 (368)         | -                    | 69.08 (31.4)   | -              |
| 3            | 18.50 (470)         | -                    | 137.5 (62.5)   | -              |
| 4            | 21.50 (546)         | -                    | 216.48 (98.4)  | -              |
| 6            | 27.75 (705)         | 12.20 (310)          | 474.32 (215.6) | 360.5 (163.88) |
| 8            | 32.75 (832)         | 13.78 (350)          | 853.6 (388)    | 391.6 (278)    |

### Class 2500 RF

| Nominal Size | API 6D Long Pattern | API 6D Short Pattern | Weight         |              |
|--------------|---------------------|----------------------|----------------|--------------|
|              |                     |                      | A lbs. (kg)    | B lbs. (kg)  |
|              | A in (mm)           | B in (mm)            |                |              |
| 1            | 12.13 (308)         | -                    | 33.33 (15.15)  | -            |
| 2            | 17.75 (451)         | -                    | 102.06 (46.4)  | -            |
| 3            | 22.75 (578)         | -                    | 239.8 (109)    | -            |
| 4            | 26.50 (673)         | -                    | 366.74 (166.7) | -            |
| 6            | 36.00 (914)         | 16.93 (430)          | 917.4 (417)    | 737 (335)    |
| 8            | 40.25 (1022)        | 18.11 (460)          | 1502.6 (683)   | 1128.6 (513) |

\*Note - For other sizes please consult factory.

## NOZ-CHEK® Quality Management and Testing



### TOTAL QUALITY MANAGEMENT

CRANE is guided by a commitment to total quality management with a focus in customer satisfaction. Cranes Quality Management System is approved to ISO 9001, API Spec. Q1 and certified to Module H of the Pressure Equipment Directive 2014/68/EU

### DESIGN

Computer-aided design (CAD) systems at CRANE are helpful in developing sound designs. Finite element analysis is utilized to conduct simulated stress analyses for various valve structures to prove design integrity. Flow modeling is applied to optimize pressure loss characteristics. Computer-generated spring designs and disc weight studies have improved the NOZ-CHEK® valve response times.

### MANUFACTURING CAPABILITIES

NOZ-CHEK® valves can be furnished in sizes from 3/4 - 84" (20 -2100 mm), and in pressure classes from ASME Class 150 - 4500 and API ratings from 2000 -15,000 psi CWP.

A variety of body and trim material is offered, including carbon steel, ductile iron, alloy steels, stainless steel and duplex steel. Coatings may be provided for added corrosion or wear resistance. Hard-facing and weld overlays may also be supplied. Seats may be metal-to-metal or bubble-tight resilient.

### TESTING

Inspection and testing are applied throughout the manufacturing process.

- Special nondestructive testing is often specified, which may include radiography, magnetic particle and liquid penetrant.
- Cryogenic and fire tests can be conducted to satisfy customer requirements. The test enclosure is able to test valves up to 72" and to pressures of 22,500 PSI, ensuring extensive coverage of the Crane Engineered Check product range.
- Each valve is hydrostatically tested to API Standard 598. These tests apply to the body shell and seat, with test duration and leakage rates pertaining to customer requirements. Other test standards are also specified in some cases.



## Additional Engineered Check Products

### Certificates

- ISO 9001
- ISO 14000
- ISO 45000
- API 6D
- PED
- FPAL
- ASME 6FD/6FA
- ABS
- CRN
- TR032

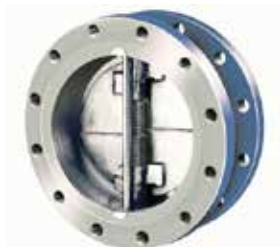

### STYLE H

#### Retainerless Wafer/ Double Flange/ lug Valves

- Sizes 2" – 84"
- ASME Classes 150 – 2500
- Ring Type Joint, Plain or Serrated Ends
- Carbon Steel, Stainless Steel and Exotic materials



### STYLE P

#### Cryogenic Duo-Chek

Sizes 2"– 36"

- ASME Classes 150-600
- Designed for cryogenic applications to -196°C



### UNI-CHEK®

#### Single-Disc Check Valves

- Sizes 2" – 36"
- ASME Classes 125 – 300
- Flanged, Plain, or Serrated Ends
- Cast Iron, Carbon Steel, and Stainless Steel
- Variety of external shaft options available



### STYLE X

#### Extended Body Wafer

Sizes 10" – 84"

- ASME Classes 150 – 2500
- Designed for extremely fast opening applications



### COMPAC-NOZ®

#### Compact Body Nozzle Check Valves

- Sizes 12" – 48"
- ASME Classes 150 – 2500
- Double Flanged / Lug / Wafer
- Carbon Steel, Stainless Steel, and exotic materials
- ASME, EN, JIS Standards

## NOZ-CHEK® Ordering Information

|            |       |                |             |      |                |                     |
|------------|-------|----------------|-------------|------|----------------|---------------------|
| 24"        | NC    | 30             | S           | M    | F              |                     |
| Valve Size | Style | Pressure Class | Body & Trim | Seal | End Connection | Modification Number |

Description: 24" Style NC, ASME Class 300, Carbon Steel Body, Buna-N Seal, Raised Face Flanges (Modification number to be assigned at order stage.)

### VALVE SIZE

Nominal valve sizes are expressed in inches, for ASME and API flange standards or millimeters for EN flange standards. (Size preceded by "M" for EN)

### SEAL Operating temperature for general guidance only

| Code Letter | Seal Material | Maximum Recommended Operating Temperatures |              |
|-------------|---------------|--|--------------|
|             |               | °C   | °F           |
| M           | Buna-N        | -25 to 110                                 | -13 to 130   |
| V           | FKM-B         | -15 to 200                                 | 5 to 392     |
| P           | Metal         | -257 to 537                                | -450 to 1000 |
| Z           | EPDM          | -25 to 120                                 | -49 to 250   |

Metal seats may be furnished as integral or special overlay materials are available.

### STYLE

| Ordering Letter | Body Style  | Size Range                             |
|-----------------|---|--|
| NC              | Integral Body, Standard API 6D Long Pattern               | 2" through 36" (50 mm through 900 mm)  |
| NCV             | Integral Body, Short Body Manufacturer's Pattern          | 36" through 84" (900mm through 2100mm) |
| TC              | Non-Integrated Diffuser API 6D Long Pattern               | 3/4" through 36" (20mm through 900mm)  |
| TCS             | Non-Integrated Diffuser Short Body Manufacturer's Pattern | 6" through 36" (150mm through 900mm)   |

### FLANGE SERIES (ASME B16.47 Series "A" or "B" to be specified over 24") guidance only

| ASME         |                |
|--------------|----------------|
| Ordering No. | Pressure Class |
| 15           | 150            |
| 30           | 300            |
| 60           | 600            |
| 90           | 900            |
| 150          | 1500           |
| 250          | 2500           |
| 450          | 4500           |

| API          |        |
|--------------|--------|
| Ordering No. | Rating |
| 21           | 2000   |
| 31           | 3000   |
| 51           | 5000   |
| 101          | 10,000 |
| 151          | 15,000 |

| Metric - EN  |        |
|--------------|--------|
| Ordering No. | Rating |
| 6            | PN6    |
| 10           | PN10   |
| 16           | PN16   |
| 25           | PN25   |
| 40           | PN40   |
| 63           | PN63   |
| 100          | PN100  |
| 160          | PN160  |
| 250          | PN250  |
| 320          | PN320  |
| 400          | PN400  |

## NOZ-CHEK® Ordering Information

24"

Valve Size

NC

Style

30

Pressure Class

S

Body & Trim

M

Seal

F

End Connection

Modification Number

Description: 24" Style NC, ASME Class 300, Carbon Steel Body, Buna-N Seal, Raised Face Flanges  
(Modification number to be assigned at order stage.)

### STANDARD BODY & DISC MATERIALS

| Code | Body                                     | Disc            |
|------|--|-----------------|
| S    | ASTM A 216 GR WCB carbon steel           | alloy steel     |
| C    | ASTM A 351 GR CF8M 316 stainless steel   | stainless steel |
| DD   | BS EN 1563 GR EN-GJS-450-10 ductile iron | stainless steel |
| GC   | ASTM A 352 GR LCC low temp. carbon steel | alloy steel     |
| DZ   | ASTM A995 GR 4A duplex stainless steel   | Duplex SS       |

Other high grade and alloy materials are available as cast and forged grades.

### SPRING MATERIAL

| Spring Material     | Maximum Recommended Operating Temperatures |      |
|---------------------|--|------|
|                     | °C   | °F   |
| 316 Stainless Steel | 300  | 572  |
| Inconel® X-750      | 550  | 1022 |

Inconel® is a registered trademark of Special Metals Corporation.  
For temperatures up to 700°F (370°C), Inconel X-750 spring temper will be furnished as standard. For higher temperatures the appropriate heat treat will be carried out.  
Other alloy spring materials are available to meet specific service requirements.

### END CONNECTIONS

| Ordering Letter | Connections                                       |
|-----------------|---|
| F               | Flanged, Raised Face, Serrated                    |
| X               | Flanged, Flat Face, Non-serrated (125 µin Max.)   |
| G               | Hub End   |
| P               | Flanged, Raised Face, Non-serrated (125 µin Max.) |
| R               | Flange, Flat Face, Ring Joint                     |
| W               | Butt Weld End                                     |

### MODIFICATIONS

A modification number is assigned when non-standard features, material mixes or documentation are ordered.



**CRANE**<sup>®</sup>

---

**CRANE CHEMPHARMA & ENERGY**

4526 Research Forest Drive,  
Suite 400  
The Woodlands  
Texas 77381, U.S.A.  
Tel: +1 936 271 6500

Sydney, Australia Operations  
146-154 Dunheved Circuit  
St. Marys, NSW 2760 Australia  
Tel: +61 2 9623 0234

Crane Process Flow  
Technologies (India) Ltd  
E7 / E8 -2 Old MIDC  
Satara - 415 004 India  
Tel: +91 2162 244417

Crane Middle East & Africa FZE  
PO Box 17415  
Jebel Ali Freezone  
Dubai, UAE  
Tel: +971 4 816 5800

---

Crane Process Flow Technologies (Belfast)  
Urban HQ, Eagle Star House,  
5 – 7 Upper Queen Street,  
Belfast, BT1 6FB  
Tel: +44 (0) 28 9070 6322

---

Crane Co., and its subsidiaries cannot accept responsibility for possible errors in catalogues, brochures, other printed materials, and website information. Crane Co. reserves the right to alter its products without notice, including products already on order provided that such alteration can be made without changes being necessary in specifications already agreed. All trademarks in this material are the property of the Crane Co. or its subsidiaries. The Crane and Crane brands logotype (CENTER LINE<sup>®</sup>, COMPAC-NOZ<sup>®</sup>, CRANE<sup>®</sup>, DEPA<sup>®</sup> & ELRO<sup>®</sup>, DOPAK<sup>®</sup>, DUO-CHEK<sup>®</sup>, FLOWSEAL<sup>®</sup>, GYROLOK<sup>®</sup>, GO REGULATOR<sup>®</sup>, HOKE<sup>®</sup>, JENKINS<sup>®</sup>, KROMBACH<sup>®</sup>, NOZ-CHEK<sup>®</sup>, PACIFIC VALVES<sup>®</sup>, RESISTOFLEX<sup>®</sup>, REVO<sup>®</sup>, SAUNDERS<sup>®</sup>, STOCKHAM<sup>®</sup>, TEXAS SAMPLING<sup>®</sup>, TRIANGLE<sup>®</sup>, UNI-CHEK<sup>®</sup>, VALVES<sup>®</sup>, WESTLOCK CONTROLS<sup>®</sup>, WTA<sup>®</sup>, and XOMOX<sup>®</sup>) are registered trademarks of Crane Co. All rights reserved.

---