

CRANE

CRYOFLO^{H₂}

Keeping Cryogenics Cool

VACUUM JACKETED MANIFOLDS

www.cranecryoflo.com

brands you trust.

REDUCED HEAT FLUX. INCREASED FLOW RATE.

CRANE CRYOFLO[®] vacuum jacketed manifolds is the optimal solution for transporting cryogenic liquids with minimal waste, maximum flexibility, and speedy delivery.

CRANE ChemPharma & Energy



Table Of **CONTENTS**

04-06	About Crane ChemPharma & Energy
07	About Crane CRYOFLO®
09	Product Overview
10-11	Key Features
12-13	Key Components
14	Product Applications
15	How to order
16	Index: Unit conversion



Crane ChemPharma & Energy **INTRODUCTION**

Crane Co. is a diversified manufacturer of highly engineered industrial products with a substantial presence in a number of focused niche markets. We are dedicated to integrity and honest dealings in all that we do.

Crane CP&E designs and manufactures a variety of high performance products including: highly-engineered check valves, sleeved plug valves, lined valves, process ball valves, high performance butterfly valves, bellows sealed globe valves, aseptic and industrial diaphragm valves, multi/quarter-turn valves, actuation, sight glasses, lined pipe, fitting and hoses, and air-operated diaphragm and peristaltic pumps. Its trusted brands are in use worldwide in many industries, including Oil & Gas, Oil Refining, Petrochemical, Power Generation, Chemical Processing, Biotechnology, and Pharmaceutical.

Crane CP&E WORLDWIDE

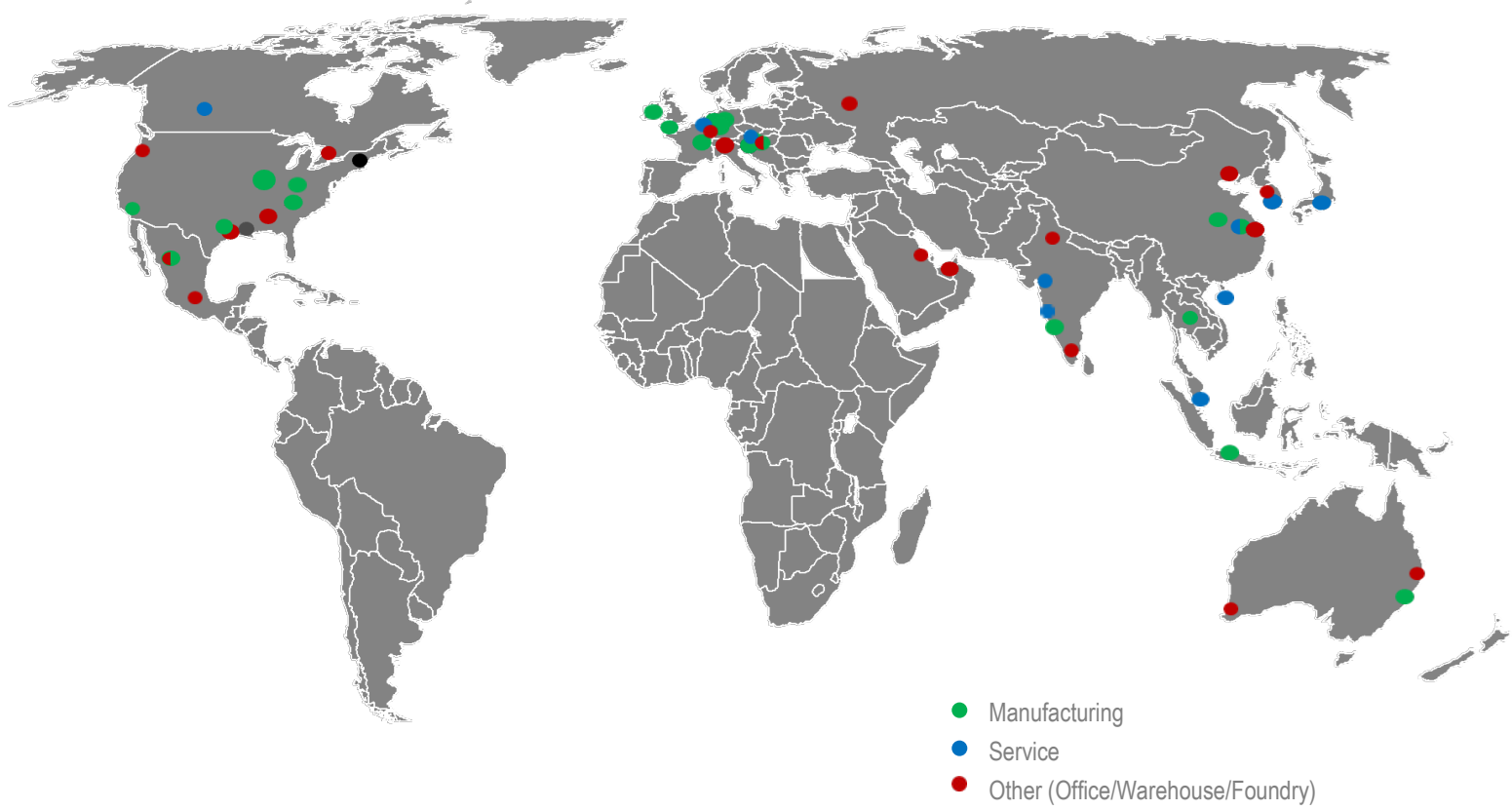

CPE MANUFACTURING SITES (Examples):



Cincinnati, OH Marion, NC Saddle Brook, NJ Muta, SL Lindau, DE Kreuztal, DE Duesseldorf, DE Cwmbran, UK Satara, India Suzhou, China Ningjin, China Singapore



AMERICAS

CHIHUAHUA, MEX • CINCINNATI, OH
• CULLMAN, AL • EDMONTON, AB
GONZALES, LA • HOUSTON, TX
• MARION, NC MEXICO CITY, MEX
• PORTLAND, OR • SADDLE
BROOK, NJ • SPARTANBURG,
SC • CONROE, TX , HQ: THE
WOODLANDS (HOUSTON), TX



EUROPE

BELFAST, UK • CWMBRAN, UK,
CRONING , SL • DÜSSELDORF, DE
• KREUZTAL, DE • LINDAU, DE •
SZÉKESVERHÉRVÁR, HU MUTA, SL
• MAXDORF, DE • MONZA, IT • MUL-
HOUSE, FR • BERGSCHENHOEK,
NL WAALWIJK, NL • WAVRE, BE •
WR. NEUDORF, AT



ASIA

BEIJING, PRC • CHENNAI (MA-
DRAS), INDIA KANAGAWA, JAPAN •
NINJIN, PRC • PUNE, INDIA SATARA,
INDIA • SHANGHAI, PRC SINGA-
PORE • SUZHOU, PRC • VIRALI-
MALAI, INDIA



AUSTRALIA

BRISBANE • KEWDALE • MEL-
BOURNE • ST. MARYS



MIDDLE EAST

AL KHOBAR, SAUDI ARABIA • DUBAI,
UAE

Local **SERVICE**

CRANE is committed to delivering efficient service and local technical expertise.

Crane is built on quality principles and practices to achieve the best safety, quality, performance, delivery, service and total cost.

Our vision as a global provider is to be the Supplier of Choice for on/off process valve solutions in chemical, power and refining, known for best-in-class customer responsiveness.



Quick access to high-demand stock



Engineering support



System design and drawings



MRO services



Training and testing

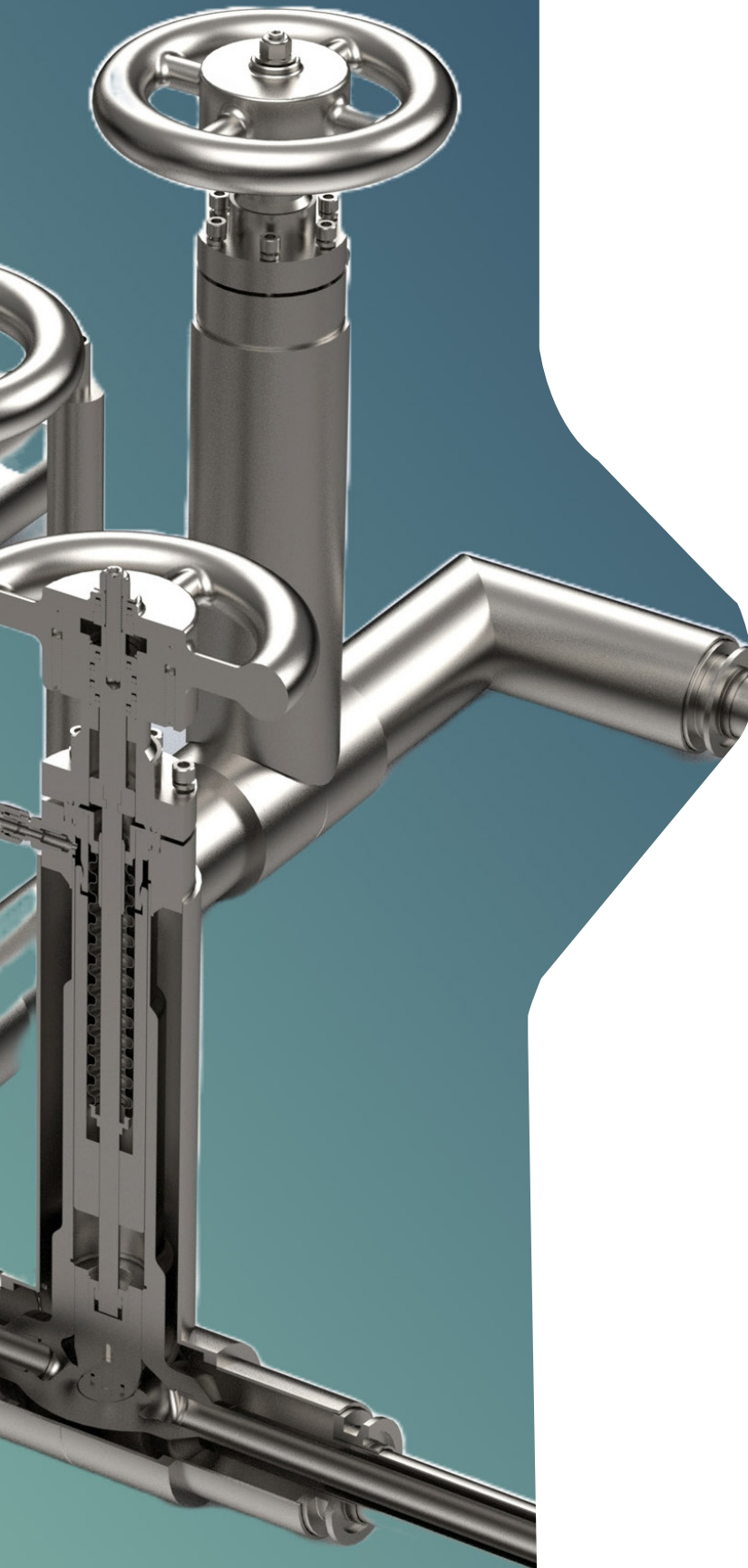



ABOUT CRANE CRYOFLO®

For hydrogen energy to be an effective and efficient alternative to fossil fuels, liquefaction plants, storage facilities, transportation methods and pipelines must be outfitted with state-of-the-art PVF (Pipe Valves and Fittings) components. Crane® CRYOFLO® will be focused on solving Customer's toughest challenges within the Hydrogen Industry backed by decades of field experience in severe service applications.

Crane® CRYOFLO® Solutions for Cryogenic Applications:

- Production
- Liquefaction
- Transportation
- Transfer
- Storage

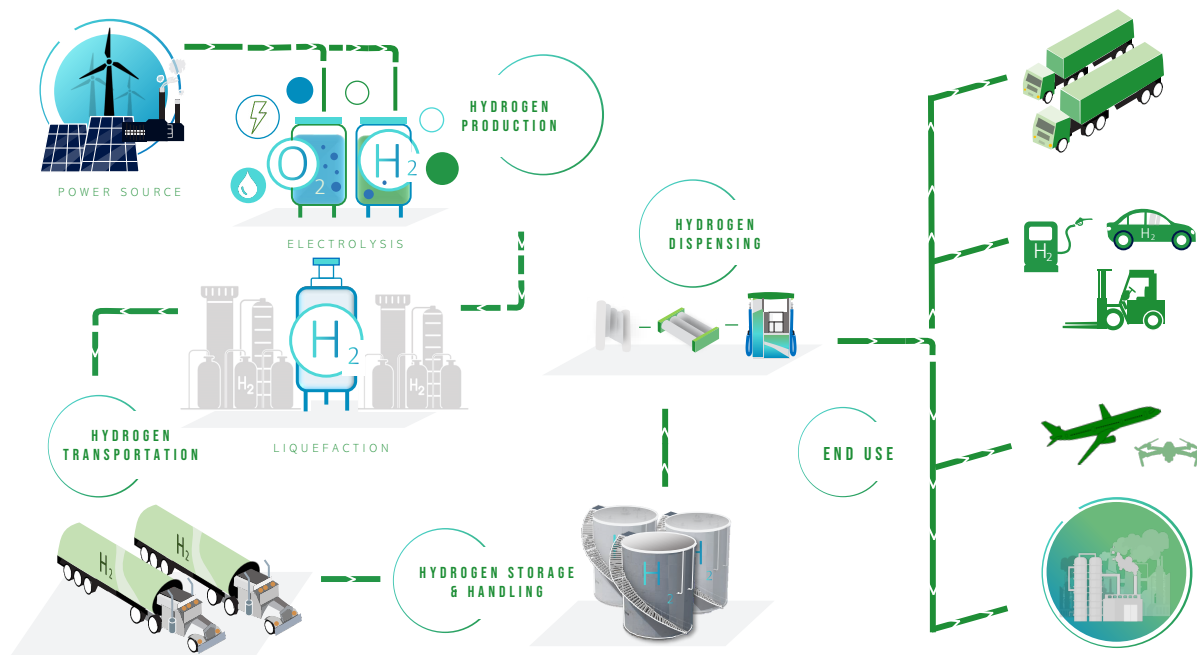



Our New Conroe Facility

Profile

- 80,000 Sq-ft
- Planned 90 Associates
- 1 Hour to downtown Houston

Core Technology

- Cryogenic Applications
- Vacuum Acquisition
- Welding/Fabrication
- Valve Automation
- Oxygen Cleaning



Vacuum Jacketed Manifolds

OVERVIEW



Storage tanks are essential for storing and transporting cryogenic fluids, such as liquid nitrogen, oxygen, and hydrogen. However, filling and withdrawing these fluids from the tanks can be challenging, as they require extremely low temperatures and high pressures to maintain their liquid state. Any heat transfer from the ambient environment can cause vaporization and pressure build-up, resulting in product loss and safety hazards.

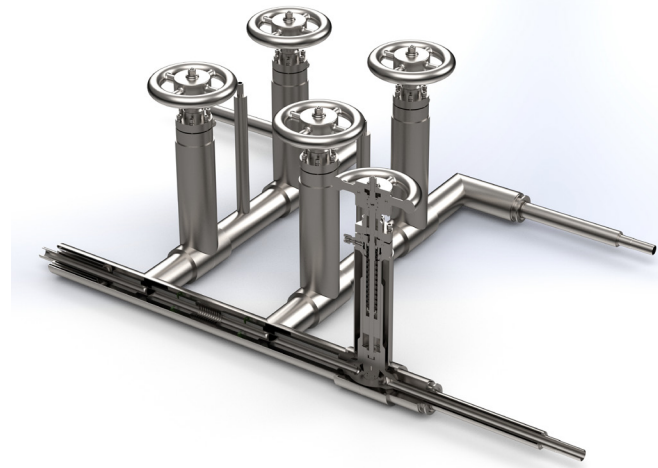

Crane® CRYOFLO® provides fully customizable manifolds that support all storage tank and trailer layouts. These manifolds consist of high-quality valves, fittings, and hoses that are designed to optimize flow rates and minimize heat transfer. The manifolds use the improved CV Bellows Seal Globe Valve, which offers excellent sealing and durability for cryogenic applications. The manifolds also have improved product connections, such as quick disconnects and bayonet couplings, that allow for easy and safe operation.



PERFORMANCE

Innovative engineered design greatly reduces Hydrogen loss through improved heat transfer and enhanced CV.



LEAD TIME

Automated facility delivers products faster and more efficiently with consistent quality.



BESPOKE SOLUTIONS

CRYOFLO® offers full customization and engineering for any tank layout.

ABOUT OUR MANIFOLDS

Thermal performance and the Flow Coefficient are two of the most critical aspects to consider when designing high-efficiency cryogenic valves. Utilizing CFD simulations & analysis integral to the design and development of new products, Crane CRYOFLO® is pushing boundaries in Hydrogen.

A SOLUTION FOR EFFICIENT STORAGE TANK FILLING AND WITHDRAWAL

Crane CRYOFLO® is committed to enhancing customer experience by offering best in class lead time and a breakthrough manufacturing and system design configurator. Customers can choose from various options and configurations to suit their specific needs and preferences. Crane CRYOFLO® is the ultimate solution for efficient and reliable storage tank filling and withdrawal.

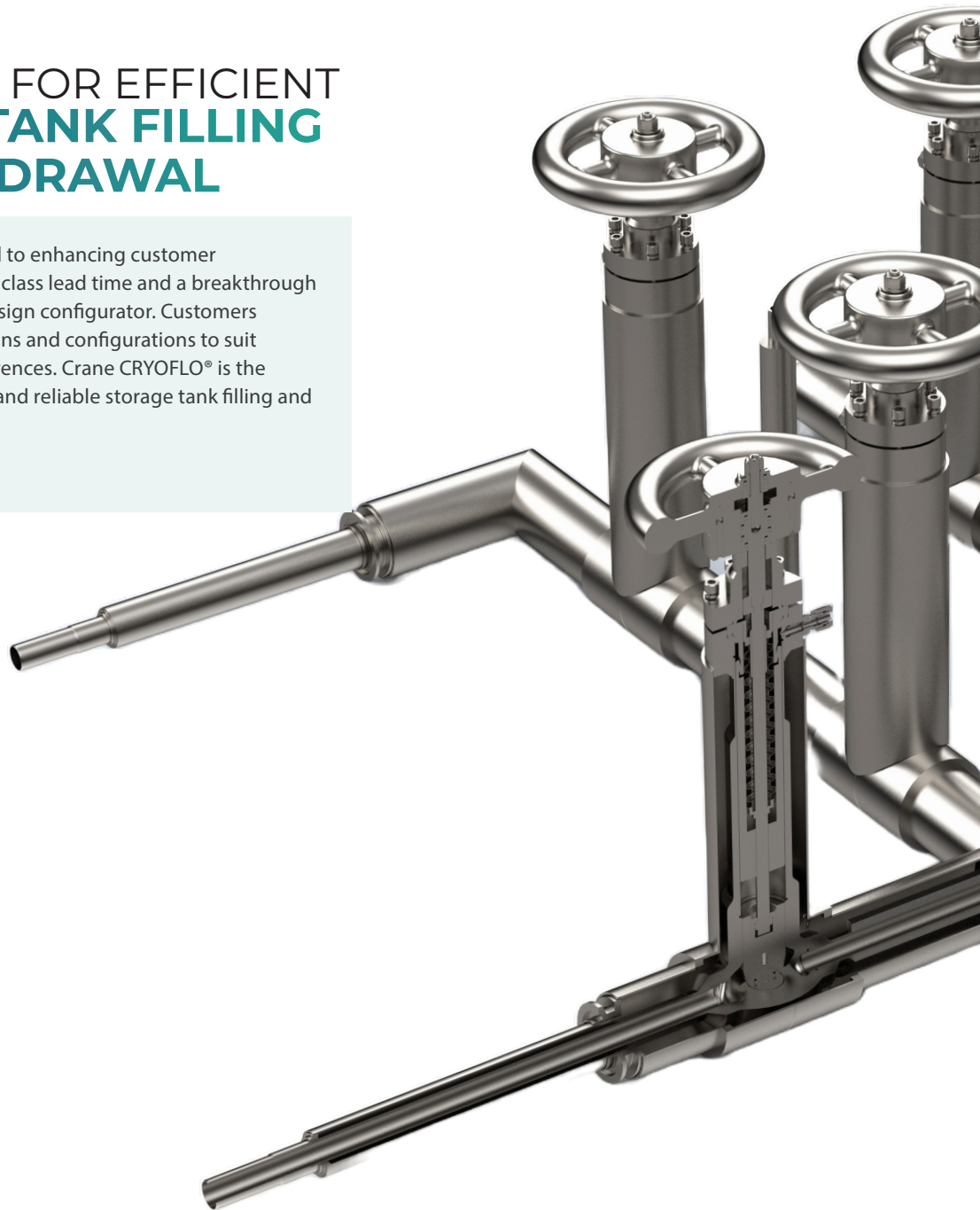

KEY FEATURES

Size Range

Inner Pipe Size: 1/2", 1", 1-1/2", 2", 3", and 4" NPS

Pressure Ratings

- 300 PSIG for Cryogenic

Materials of Construction

- 300 Series Stainless Steel

Design Standards and Compliance

- Built in accordance with ASME B31.3: Process Piping
- ASME B31.12: Hydrogen Piping & Pipeline
- CGA G-4.15: Vacuum-Jacketed Piping in Liquid Oxygen Service
- CGA G-5.6 – Hydrogen Pipeline Systems
- ASME B36.19M : Stainless Steel Pipe
- ASME BPVC Section IX: Welding and Brazing Qualifications
- NFPA 2 – Hydrogen Technologies Code
- AWS B1.10 & ISO 17035: Guide for nondestructive examination of welds
- ASME BPVC Section V – Nondestructive Examination

End Connections

- Bayonet
- Field Joint
- Mechanical Fitting

Design Features

- Fugitive Emission: Helium mass spec to 1×10^{-9} cm³/s
- Outgassing Getter, Molecular Sieve & Multi-Layer Insulation for Static Vacuum
- ASME B31.3 Certification
- Pressure Drop, Heat Leak, and Thermal Contraction of the System
- Internal G-10 Supports and Outer Pipe Supports



KEY COMPONENTS

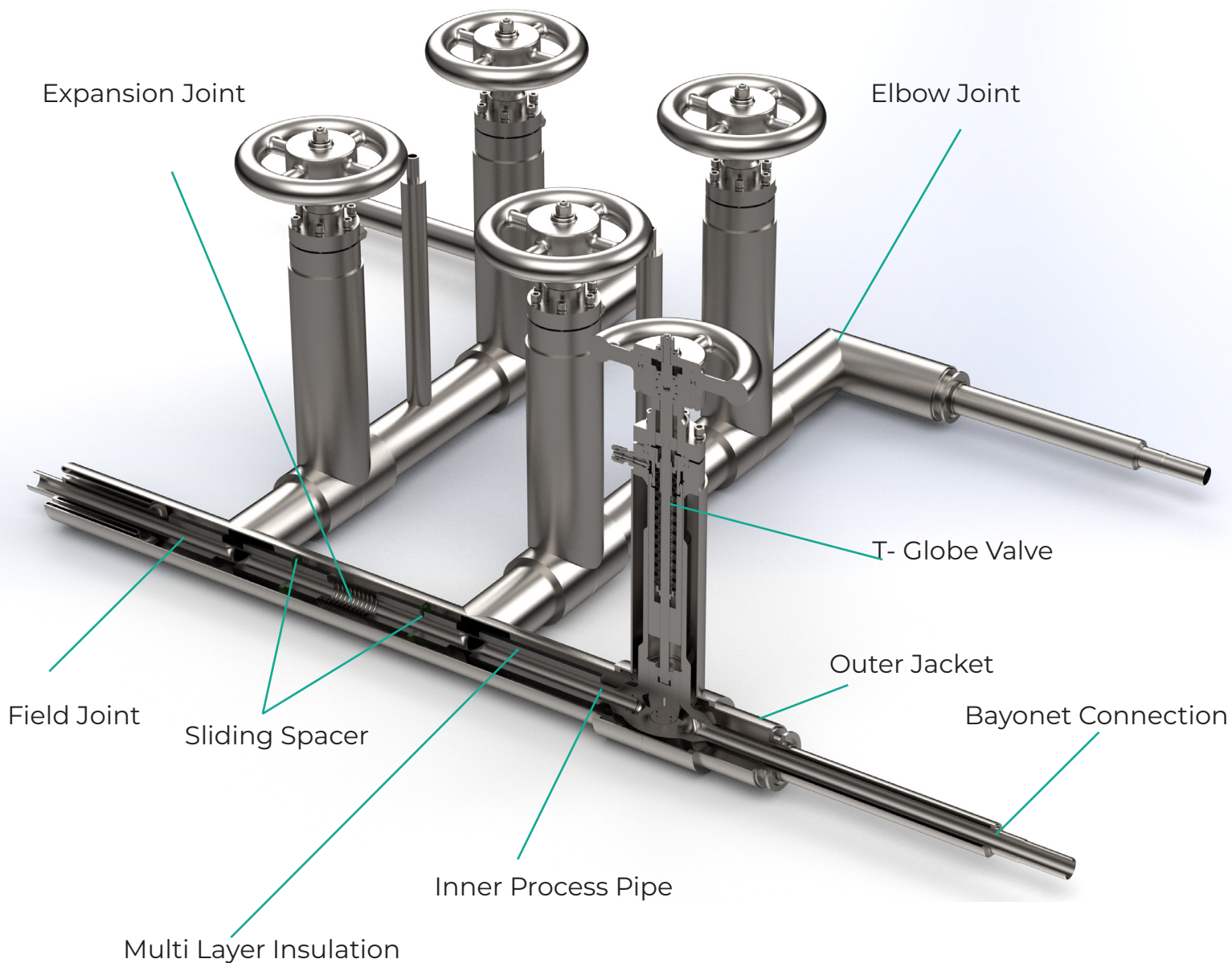
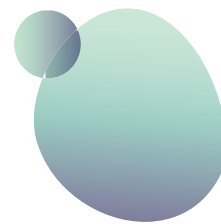

Designed for LH2 and other key industrial gases such as LIN, LOX, LAR, and LNG. Rated to -253°C (-423.4°F)

KEY COMPONENTS

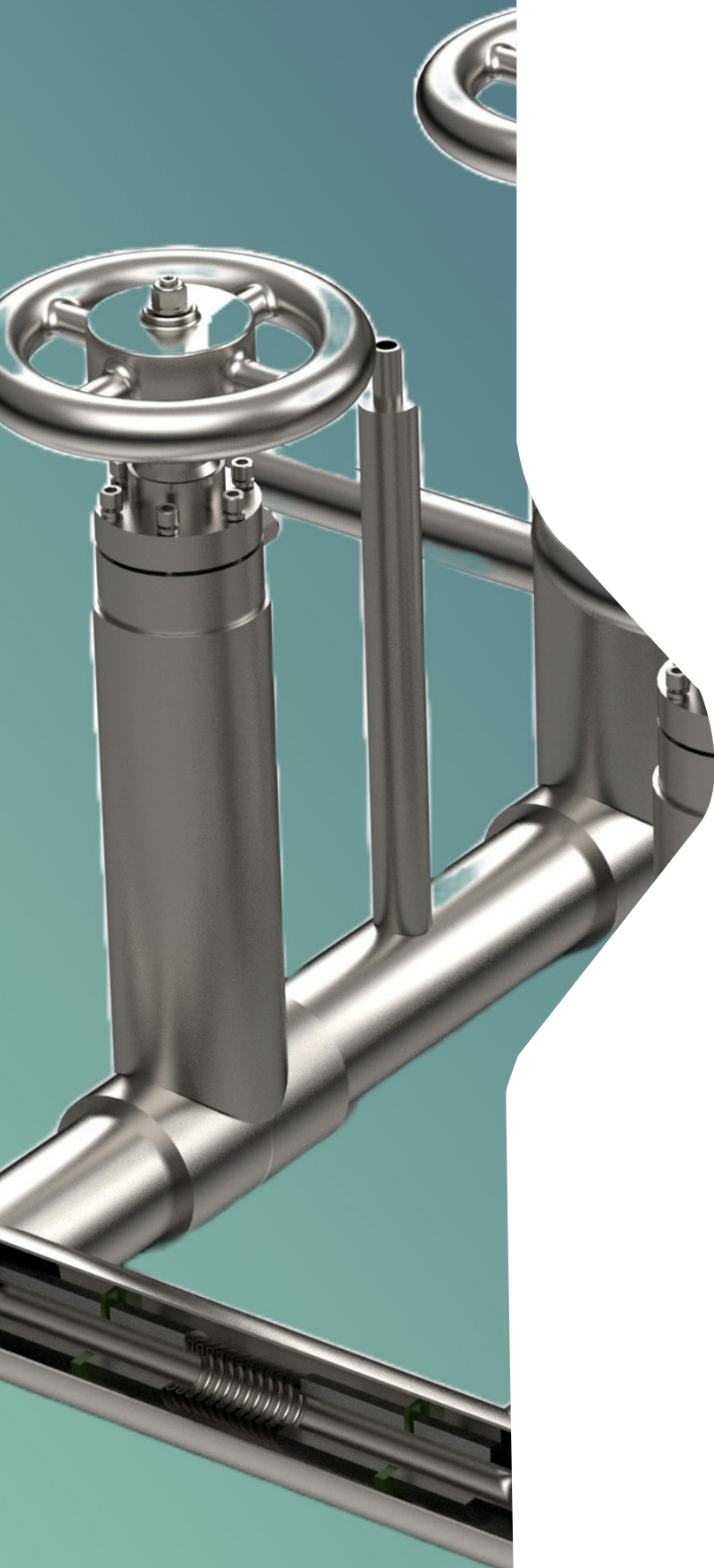

Expansion Joint

An expansion joint is a device that allows for the expansion and contraction of the piping system due to temperature changes. Expansion joints are especially important in VJP systems because cryogenic liquids have a very high coefficient of thermal expansion.

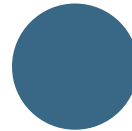

Field Joint

A field joint is a type of joint that is used to connect two sections of VJP piping in the field. Field joints are typically flanged or welded joints.



Sliding Spacer

A sliding spacer is a device that allows for the relative movement of the inner pipe and outer jacket of a VJP system. Sliding spacers are important because they prevent the vacuum jacket from being damaged by the expansion and contraction of the inner pipe.

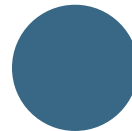

Multi Layer Insulation

Multi layer insulation (MLI) is a type of insulation that is used in VJP systems to reduce heat transfer from the surrounding environment. MLI consists of multiple layers of reflective material and non-conductive material.



Inner Process Pipe

The inner process pipe is the pipe through which the cryogenic liquid flows. The inner process pipe is typically made of stainless steel.

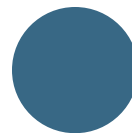

Bayonet Connection

A bayonet connection is a type of quick-release connector that is used in VJP systems. Bayonet connections are easy to connect and disconnect, and they are typically used to connect the VJP system to the storage tank.



Outer Jacket

The outer jacket is the pipe that seals the vacuum space and forms a "vacuum jacket." The outer jacket is typically made of stainless steel.



Valve

A valve is a device that is used to control the flow of cryogenic liquid through the VJP system.



Elbow Joint

An elbow joint is a type of fitting that is used to change the direction of a VJP system. Elbow joints are typically made of stainless steel.



Photos provided as courtesy by CHART



PRODUCT APPLICATIONS

Vacuum jacketed storage tank fill and withdrawal assemblies are the next generation of cryogenic fluid transfer technology. These fully customizable manifolds are designed to support all storage tank and trailer layouts, while minimizing heat transfer rates and maximizing flow rates.

1

Primary Target: LH2

Liquid hydrogen (LH2) is an extremely cold cryogenic fluid with a boiling point of -252.9°C . This makes it ideal for use in applications where extreme temperatures are required, such as aerospace propulsion and fuel cells.

One of the biggest challenges in handling LH2 is heat loss. Due to its extremely low temperature, LH2 is very good at absorbing heat from the surrounding environment. This can lead to significant boil-off, which can waste product and increase costs.

Vacuum jacketed storage tank fill and withdrawal assemblies are ideal for handling LH2 because they minimize heat transfer. The vacuum jacket creates a barrier between the LH2 and the outside environment, which helps to keep the LH2 cold and reduce boil-off.

In addition, vacuum jacketed assemblies are designed to maximize flow rates. This is important because LH2 is a very viscous fluid. By maximizing flow rates, vacuum jacketed assemblies can help to reduce pumping costs and improve operational efficiency.

2

Secondary Target: LN2

Liquid nitrogen (LN2) is another commonly used cryogenic fluid with a boiling point of -195.8°C . LN2 is used in a wide range of applications, including industrial manufacturing, food processing, and medical research.

One of the key advantages of LN2 is its large addressable market. LN2 is used in a wide variety of industries and for a variety of purposes. This makes it a very attractive target market for vacuum jacketed storage tank fill and withdrawal assemblies.

In addition, vacuum jacketed assemblies can help to reduce the cost of LN2 operations. By minimizing heat transfer and maximizing flow rates, vacuum jacketed assemblies can help to reduce boil-off and pumping costs.

HOW TO ORDER



* ORDER EXAMPLE AVAILABLE BELOW

PRODUCT	
M	Manifold Pipe System

SIZE	
005	1/2"
010	1"
015	1 1/2"
020	2"

APPLICATION	
H2	Hydrogen
HE	Helium
N2	Nitrogen
AR	Argon
NG	Natural Gas
O2	Oxygen

ORDER EXAMPLE: M-010-N2

1" size Manifold Pipe System for cryogenic Nitrogen application

UNIT CONVERSION DATA FOR CRYOGENICS

	WEIGHT		GAS		LIQUID	
	pounds (lbs)	kilograms (kg)	cubic feet (scf)	cu meters (Nm ³)	gallons (gal)	liters (l)
1 pound	1.0	.4536	192	5.047	1.6928	6.408
1 kilogram	2.205	1.0	423.3	11.126	3.377	14.128
1 scf gas	.00521	.00236	1.0	.02628	.00882	0.03339
1 Nm ³ gas	.19815	.08988	38.04	1.0	.3355	1.2699
1 gallon liquid	.5906	.2697	113.4	2.981	1.0	3.785
1 liter liquid	.15604	.07078	29.99	.7881	.2642	1.0

CRYOGEN	BOILING POINT (°F)	CRITICAL PRESSURE (PSIG ^a)	LIQUID DENSITY (g/L)	GAS DENSITY (27°C,g/L)	LIQUID-TO-GAS EXPANSION RATIO	TYPE OF GAS
Argon	-186(-303)	710	1402	1.63	860	Inert
Helium	-269(-452)	34	125	0.16	780	Inert
Hydrogen	-253(-423)	188	71	0.082	865	Flammable
Nitrogen	-196(-321)	492	808	2.25	710	Inert
Oxygen	-183(-297)	736	1410	1.4	875	Flammable
Methane	-161(-256)	673	425	0.72	650	Flammable
CO ₂	-79(-108)	1071	100	20	535	Inert

NOTES

Area with horizontal green lines for taking notes.

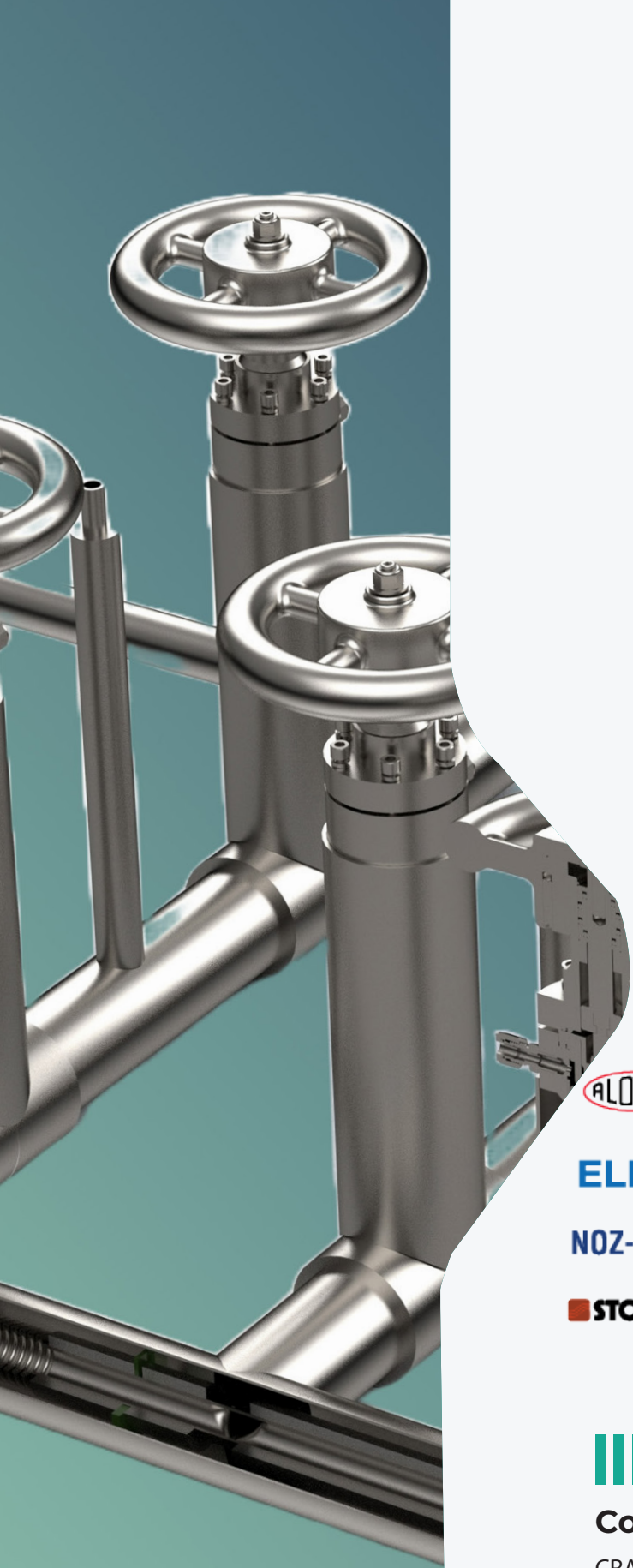

CRANE

CRYOFLO H₂

Keeping Cryogenics Cool

INNOVATION DRIVEN BY YOUR NEEDS

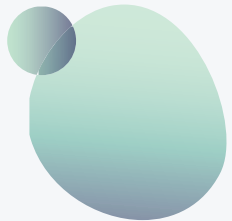

Our businesses are known for proprietary and differentiated technology, quality and reliability, deep vertical expertise, and responsiveness to unique customer needs.

brands you trust.



COMPAC-NOZ

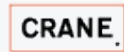

DEPA

ELRO DUO-CHEK



KROMBACH
ARMATUREN

NOZ-CHEK



RESISTOFLEX



Saunders
the science inside

STOCKHAM

UNI-CHEK

WESTLOCK
CONTROLS

wta:

XOMOX



Corporate Office:

CRANE CHEMPHARMA & ENERGY
4526 Research Forest Drive,
Suite 400, The Woodlands, TX 77381
USA
Tel.: +1-936-271-6500

CRANE

ChemPharma & Energy