



**INSTALLATION, OPERATION AND
MAINTENANCE MANUAL**
Floating Ball Design

KROMBACH® TUFSEAT™
Performance Series Ball Valves

TUFSEAT by KROMBACH - THE SUPERIOR MSBV

CRANE
®

v in www.cranecpe.com

Installation, Operation & Maintenance

1. General

1.1 Area of Application

This operating manual applies for ball valves produced by Friedrich Krombach GmbH Armaturenwerke.

The operating manual also applies to identical valves from other companies if these valves were delivered through Krombach and the contract documents for the delivered valves expressly mention this operating manual. Before the valves are used, the manual must be read carefully and completely.

If there are any discrepancies or if anything is unclear, please contact KROMBACH.

1.2 Warning of Danger

ATTENTION

If the following caution and warning notes are not observed, this can lead to dangerous situations and the manufacturer's warranty could become ineffective. Please contact KROMBACH if you have any queries.

1.2.1 Installation, Maintenance and Operating Personnel.

ATTENTION

To avoid endangering persons and equipment, expert staff must be used for fitting, maintenance and operation. (see DIN IEC 3/B/244/CDV)

1.2.2 Carrying out fitting work on valves

ATTENTION

Fitting work on pressurized parts of the valve may only be carried out when the pipeline is depressurized. To prevent pressure and/or medium being trapped inside the ball valve, put the valve in the half-open position. The valve must have cooled down to ambient temperature before work is started.

ATTENTION

Fitting work on pressurized parts of valves for caustic or toxic flow media may only be carried out following additional emptying and bleeding of the valve and the respective pipeline.

ATTENTION

Caution! Valves have dead spaces where residue (under pressure) can remain after the flow medium has been emptied.

ATTENTION

The same safety requirements apply to valves as to the pipeline system they are built into and for the control system that is attached to the drive if appropriate. This manual only states the safety instructions that have to be heeded in addition for the valves.

ATTENTION

The safety instructions listed also apply to any heating sheath. The manufacturer's specifications are valid for attachment parts. The manufacturer's manuals contain additional safety instructions for the attached parts.

1.3 Product identification and marking

1.3.1 General Designation

The valve must be checked for correlation with the specification after delivery, by the customer and before installation in the system.

Standard-series valves produced by Krombach are marked by:

- FK Manufacturer's mark
- Nominal size (DN or NPS)
- Nominal pressure (PN or Class)
- Material designation for valve body and cover

1.3.2 Designation with type designation plate

Valves that have been designed and confirmed for special operating data have a name plate attached.

The name plate has the following marking:

- FK Manufacturer's mark
- (DN or NPS) Nominal diameter
- Maximum operating pressure at maximum operating temperature in
- Model year
- Consignment figure and serial number

Installation, Operation & Maintenance

1.3.3 CE Designation

Valves that are subject to CE marking are marked additionally by:

- CE mark
- Code of the issuing office

1.3.4 Valves for Oxygen

Valves for oxygen (O₂) have additional markings:

- "Oil and grease-free, suitable for oxygen"

1.4 Condition on delivery, transport and storage

The valves are delivered with an outer coating, sealed with protective caps, and in an open position.

Valves made of stainless steel are not coated.

ATTENTION

The valve must be stored dry in its original packaging and/or sealed with protective caps.

Sealing surfaces and threads in particular must not be damaged mechanically or through any other factors.

ATTENTION

Valves for oxygen are delivered sealed in film. Shipping and storage must be carried out in such a way that the film does not become damaged. Only undamaged transport film guarantees freedom from oil and grease as packed after manufacture.

ATTENTION

Lifting equipment must be fixed to the valve body. The coating, handwheel and accessory parts must not become damaged by the lifting equipment being hooked on.
Lifting equipment must not be hooked to handwheel or valve spindle. **ACCIDENT HAZARD! DAMAGE** to the product!

The valves should be stored in closed, dry rooms on a firm clean base.

2. Product

2.1. Proper Use

The valves have been designed exclusively for installation into a pipeline system to block off or guide through media.

ATTENTION

A valve may not be used if its permissible pressure/temperature range ("rating") is not sufficient for the operating conditions. The permitted values can be found on the valve name plate or the product data sheet. Special approval is required from KROMBACH for use of the valve outside these values.

Disregarding this regulation can lead to danger to life and limbs and cause damage in the pipeline system.

ATTENTION

It must be guaranteed that the parts of the valve that come into contact with the media are made of materials suitable for the media used. KROMBACH will not accept liability for any damage caused by corrosion through aggressive media.

Disregarding this regulation can lead to danger to life and limbs and cause damage in the pipeline system.

ATTENTION

For valves that are used as an end valve:
During normal operation, in particular with gaseous, hot and/or hazardous media, **a blind flange or cap must be fitted to the open connection** or (only suitable for short-term use!) the valve must be safely locked in the "CLOSED" position.

ATTENTION

If the valve has to be opened as an end valve in a pressurised line, this must be done extremely carefully so that the **medium sprayed** out does not cause any damage.
Be careful when closing such a valve: Danger of crushing between housing and ball!

ATTENTION

If a valve has to be removed from a pipeline:
Medium can escape from the pipeline or the valve. In the case of media that can be harmful to health or are hazardous, the pipeline has to be completely emptied before the valve is removed. Be careful of **residue that can flow out of dead spaces in the valve or the pipeline or have remained in the valve (under pressure).**

Installation, Operation & Maintenance

⚠ ATTENTION

Make sure that valves that have been operated at operating temperatures of $> 50^{\circ}\text{C}$ or $< 20^{\circ}\text{C}$ and the pipeline connections cannot be touched by the operator, in order to protect the operator from injury.

- The usual flow speeds analogue to EN 593:2004 Table 2 must be observed during permanent operation in the pipeline system. Abnormal operating conditions such as vibrations, pressure surges, erosion, cavitation and more than small shares of solids in the medium – in particular abrasive solids – must be clarified with KROMBACH.
- Media to be conveyed may only have a very small share of solids that can damage or block the seal system.
- The use of abrasive media is not recommended.
- The valves should not be used for media that are prone to inner deposits.
- If a valve is to be used for throttling in permanent operation, this must be agreed when the order is placed. The application limits must always be agreed upon with KROMBACH (agreed with KROMBACH for cavitation free operation).
- The application limits must always be agreed upon with KROMBACH for cavitation-free operation.

2.1.1 Method of Operation

- Ball valves are actuated using a hand lever. (Actuation through gear/drive see 2.7.5)
- A ball with cross-hole is used as a blocking fitting, which either releases or blocks the full medium flow through a swivel movement of 90° .
The valve is closed by turning the hand lever to the right (clockwise).
The valve is opened by turning the hand lever to the left (anti-clockwise).
Respective instructions are on the hand lever itself.
- No torque-enhancing aids may be used to actuate the valve.

2.1.2 Design and technical data

The technical design of the valves corresponds to the enclosed documentation.

All the dimensions, materials, special versions, accessories and any further specifications can be found in the enclosed ORDER-RELATED DOCUMENTATION.

The images in the exploded views are only design examples.

2.2 Installation in the Pipeline

2.2.1 General Instructions

- Before installation in the pipeline, the valve must be checked to make sure that it matches the specification for the installation location
- Clean the valve of storage and transport dirt
- Remove the cap from the valve
- The connection pipeline and pipeline connection flanges must be parallel and the correct distance apart.
- When the system is being painted after valve installation, the stem must remain free of paint.
- When media are used at an operating temperature of under 0°C , the valve has to be dry before it is put into operation.
- Pipelines designed for steam to flow through them must be routed in such a way that condensation draining is possible and water hammers are excluded.
- If fittings are insulated, care must be taken that the stuffing box area remains accessible and controllable in the operating state.

2.2.2 Installation position and Direction

The ball valves can be installed in any position, but can be restricted by accessories (e.g. drives).

The normal installation position is to be preferred > stem vertically upright.

The installation position with the stem hanging downwards must be avoided because operating medium can spill over the hand lever if the stem seal is leaking.

If there is a danger of the valves freezing, only the normal installation position is permissible, and the valves must have a draining fitting in the central housing section. The mode of operation must guarantee that the valve does not become damaged by freezing medium.

⚠ ATTENTION

Uni-directional valves need to be installed in the preferred direction as indicated by the arrow on the tag of the valve.

Installation, Operation & Maintenance

⚠ ATTENTION

Where liquid media with great strain on the body and cover under pressure. Heat expansion and temperature fluctuations are used in the system. Impermissibly high pressures can result, which place too great a strain on the body and cover under pressure. In such cases, the valve and the pipeline must be secured against impermissibly high pressure. The dead spaces in the valve must be secured separately by means of a pressure-relief bore hole or other measures.

⚠ ATTENTION

When the valve is installed in the pipeline, the arrow on the fitting must point in the pressure direction. Tightness in the opposite direction is not guaranteed.

2.2.3 Installation

- The valve has to be installed without tension in a clean pipeline.
- Before the valves are installed, check that the connection dimensions of the valve flanges or the welding end connectors match those of the pipeline.
- The flange seals must be centred.
- The fastening screws on the connection flanges must be tightened evenly and crosswise.
- Welded valves are to be welded in place without tension, taking technical rules into account. (Welding and any heat treatment that may be necessary takes place at the responsibility of the pipeline construction company).
- The valve may not serve as an anchor in the pipeline system; it must be carried by the pipeline.

2.3 Commissioning

- Before the valve is put into operation, check that the correct valve has been installed in installation position according to 2.3.2.
- Check the correct position of the valve in relation to the way the system works.
- All installation work must be completed correctly before operation is started.
- Check the valve for leaks during and after it has been put into operation by means of visual inspection.

2.4 Maintenance and Testing

2.4.1 Maintenance Interval

Depending on the type of system and operating data involved, the valve will need some maintenance.

The maintenance interval must be determined by the system owner-operator on the basis of his specific operational experience. In particular, air tightness and function must be checked regularly according to operational experience or legal regulations.

⚠ ATTENTION

CAUTION! Valves for the flow medium oxygen must not be allowed to come into contact with unsuitable materials, e.g. lubricants!

2.4.2 Testing Pressure

The testing pressure for recurring tests must not exceed the value of the testing pressure at the manufacturer's. This can be found in the valve's acceptance test certificates.

2.4.3 Stuffing Box on Ball Valves

- Check that the stuffing box is leakproof.
- If the stuffing box is not leakproof, tighten carefully until it is.
- Valve actuation must be guaranteed, however.
- If tightness cannot be achieved, the stuffing box packing must be replaced.

⚠ ATTENTION

The stuffing box packing may only be replaced when the instructions under section 1.2 + 2.8 of this operating manual are taken into account.

⚠ ATTENTION

The packing ring material must be resistant to the flow medium and be suitable for the respective operating data, operating pressure and operating temperature.

The special packaging instructions of the packing manufacturer must be taken into account for the different packing materials, or the valve manufacturer must be consulted if necessary.

Installation, Operation & Maintenance

2.4.4 Body gaskets and packing

Check the sealing elements for tightness. If they are not leakproof, tighten with the valve depressurised. If tightness is not achieved, a new body gaskets and packing must be used.

⚠ ATTENTION

The sealing elements must be replaced with the valve depressurised, the requirements of section 1.2 + 2.8 of this operating manual must be met.

2.5 Faults and Fault Rectification

- Determine and define the type of problem.
- If the problem is caused by a heavy leak, the leak spot should be localised if possible.
- Inform KROMBACH. (See Warranty section 2.9)

2.6 Accessories

2.6.1 Final Position Switch

The installed final position switches must be connected according to the respective circuit diagram and checked for correct adjustment.

2.6.2 Locking Fixtures

To prevent the valve being actuated unintentionally, which could lead to danger, locking and catch fixtures are available from the manufacturer.

2.6.3 Special Accessories and Versions

Additional specifications must be heeded for valves with special accessories or for special versions.

2.6.4 Valves with Gear and/or Actuator

⚠ ATTENTION

Special mounting, maintenance and operating instructions from the manufacturer are valid for gears and/or drives!

Please contact KROMBACH if you have any queries.

⚠ ATTENTION

Ball valves with gear, electric/pneumatic setting drive are installed in the normal installation position: Stem vertically upright (drive at the top) in the pipeline.

This installation position must be observed!

KROMBACH must be consulted if other installation positions are required!

- The direction of rotation (clockwise = CLOSE; anti-clockwise = OPEN) remains the same whether the valve is actuated by means of the gear handwheel or the electric/pneumatic actuating drive!

⚠ ATTENTION

The connection of electric cables may only be carried out by specialised staff.

Applicable regulations, in particular VDE 0100 and VDE 0165 (explosion protection) must be heeded.

2.6.5 Retrofitting Actuators

⚠ ATTENTION

The very wide range of operating conditions and possible installation positions must be taken into consideration in particular when retrofitting drives.

KROMBACH must always be consulted in such cases!

2.7 Repairs

Repairs and service work on valves may only be carried out by the manufacturer or trained staff, see also section 1.2.

2.7.1 Repairs at the Manufacturer's

- Due to increased efforts to protect the environment and the health of our employees, we need to know from you which materials the ball valves to be repaired by our employees have been in contact with.
- Our service technicians may not do any work without this contamination declaration.
- To avoid unnecessary expenditure and delay for you and us, we require your contamination declaration together with the order and shipping papers in the event of repair or replacement work (form is attached or can be requested from us).

2.7.2 Repairs at the Operator's

If the valve cannot be repaired at the manufacturer's, this work should be carried out by a service fitter or by trained operator staff. Only original spare parts may be used for this.

Installation, Operation & Maintenance

2.7.3 Repairs at the Operator's

A repair of balls and seat rings, by grinding and polishing, can be accomplished exclusively at the manufacturer. If this is not possible, new parts must be used from the manufacturer.

2.8 Warranty

The warranty for this product is regulated by the General Terms and conditions of Krombach and with the supply contract concluded.

- During the warranty period, the valve may only be removed or opened with the approval of KROMBACH or in the presence of a KROMBACH representative.

2.9 Declaration of responsibility for user safety

**NOTE - RESPONSIBILITY OF THE USER
FAILURE OR IMPROPER SELECTION OR IMPROPER USE
OF THE PRODUCTS OR RESPECTIVE PARTS DESCRIBED
IN THIS MANUAL CAN CAUSE FATALITIES, INJURY OR
PROPERTY DAMAGE.**

This document and other information from Krombach contain product or system options for further investigation by users with technical know-how.

The user is solely responsible for the final selection of system and components through examination and testing, and for making sure that all the capacity, durability, maintenance, safety and warning requirements of the application are met. The user has to examine all aspects of the application carefully, follow applicable industrial standards and heed the information related to the product in the current product catalogue as well as all other documents that are provided by Krombach.

As far as Krombach delivers components or system options based on technical data or specifications that have been provided by the user, the user is responsible for checking that these technical data and specifications are suitable and sufficient for all applications and reasonably predictable purposes of application of the systems.

Trouble-Free Operation

The KROMBACH TUFSEAT Performance Series Ball Valves, applied within their pressure and temperature limitations, properly installed, adjusted, and operated, should require minimum attention supplying long-term, trouble-free

service in a wide variety of applications.

READ CAREFULLY

The following procedures and illustrations have been prepared to assist you in the maintenance and repair of your Process Ball Valves. Please read these instructions carefully.

ATTENTION

Read And Understand Instructions Before Servicing Valve

Failure to follow instructions could result in death or serious injury. If you have any questions, **please contact the factory at +1 (513) 745-6000 in the Americas and sales_lindau@cranecpe.com elsewhere.**

ATTENTION

These instructions have been prepared for valves as they are currently manufactured. If you have an older design valve that needs repair, contact either the factory or your nearest Service Center to make sure that you have the correct repair parts and instructions.

Maintenance

All KROMBACH TUFSEAT Performance Series ball valves stem seals are adjusted and factory tested for tight shut-off, normally no further adjustment is necessary. If leakage should occur along the stem, follow the simple adjustment instructions below.

ATTENTION

Special applications may require no grease at all or require special types of grease. Please consult factory to get additional information.

Note: Grease types

- 1) For seat and seat seal area surfaces in body and tail use weicon anti-seize nickel assembly paste
- 2) For bolts, nuts & screws use castrol optimal paste TA

Torques

Body joint bolting torques, Table-A

Class 150						Class 300					
Valve Size		Bolt QTY	Bolt size	Bolt Torque		Valve Size		Bolt QTY	Bolt size	Bolt Torque	
(inch)	(DN)	(no's)	(inch)	(Nm)	(In-lbs)	(inch)	(DN)	(no's)	(inch)	(Nm)	(In-lbs)
½"	DN15	4	5/16"-18UNC	16	142	½"	DN15	4	3/8"-16UNC	28	248
¾"	DN20	4	5/16"-18UNC	16	142	¾"	DN20	4	3/8"-16UNC	28	248
1"	DN25	4	5/16"-18UNC	16	142	1"	DN25	4	3/8"-16UNC	28	248
1 ½"	DN40	4	7/16"-14UNC	45	398	1 ½"	DN40	4	½"-13UNC	70	620
2"	DN50	4	7/16"-14UNC	45	398	2"	DN50	4	5/8"-11INC	70	620
3"	DN80	4	5/8"-11INC	140	1239	3"	DN80	4	5/8"-11INC	140	1239
4"	DN100	8	½"-13UNC	140	1239	4"	DN100	8	5/8" 11INC	140	1239
6"	DN150	8	¾"-10UNC	240	2124	6"	DN150	16	¾"-10UNC	240	2124

Axial force for pre-deforming body gasket and seat seal, Table-B

Valve Size & Pressure Class			Body gasket	Ball (seat seal)
DN	NPS	Class / PN	F [kN]	F [kN]
15	½"	150-300 / 10-40	38,6	1,6
20	¾"	150-300 / 10-40	57,7	2,6
25	1"	150-300 / 10-40	57,7	3,8
40	1 ½"	150-300 / 10-40	90,9	8,0
50	2"	150-300 / 10-16	90,9	12,8
50	2"	300 / 25-40	98,0	12,8
80	3"	150-300 / 10-40	134	29,7
100	4"	150-300 / 10-40	272	48,8
150	6"	150-300 / 10-40	399	110

Stem Seal Adjustment

STEM SEAL ADJUSTMENT (Threaded Packing Gland)
Sizes: 1/2"-2" Cl.150 & 300, 3" Cl.150 (1156, 1176)

Note: If a tight seal cannot be obtained, continue with the instructions for valve repair.

To adjust for leakage along the valve stem, turn the Threaded Packing Gland (#8) clockwise in approximately 1/3- turn increments to compress the packing (#13). Use torques from following table.



KFO1176: STANDARD TRIM

KFO1156: HIGH TEMPERATURE TRIM

Valve Size		Pressure Class	Threaded Packing Gland size	Threaded Packing Gland Torque			
				KFO1176		KFO1156	
(inch)	(DN)	(Class)	(metric)	(Nm)	(in-lbs)	(Nm)	(in-lbs)
1/2"	DN15	#150 & #300	M30	116	1026	116	1026
3/4"	DN20	#150 & #300	M30	116	1026	116	1026
1"	DN25	#150 & #300	M30	116	1026	116	1026
1 1/2"	DN40	#150 & #300	M36	224	1982	224	1982
2"	DN50	#150	M36	224	1982	224	1982
2"	DN50	#300	M48	390	3452	390	3452
3"	DN80	#150	M48	390	3452	390	3452

Stem Seal Adjustment

STEM SEAL ADJUSTMENT (Bolted Packing Gland) Sizes: 3" CI.300, 4"-6" CI.150 & 300 (1156, 1176)

To adjust for leakage along the valve stem, turn the packing adjustment bolts (#21) (6pcs or 8pcs) clockwise, in approximately 1/2-turn increments to compress packing

gland (#8) and packing (#13). Use torques from following table. (When tightening packing bolts, use proper crisscross adjustment pattern as shown below).

Note: If a tight seal cannot be obtained, continue with the instructions for valve repair



KFO1176: STANDARD TRIM



KFO1156: HIGH TEMPERATURE TRIM

Valve Size		Pressure Class	Packing Gland Bolt size	Quantity	Packing Gland Bolts Torque			
					KFO1176		KFO1156	
(inch)	(DN)	(Class)	(inch)	(no's)	(Nm)	(in-lbs)	(Nm)	(in-lbs)
3"	DN80	#300	7/16"	6	27	239	18	159
4"	DN100	#150	7/16"	6	27	239	18	159
4"	DN100	#300	7/16"	8	24	212	17	150
6"	DN150	#150	7/16"	8	24	212	17	150
6"	DN150	#300	1/2"	8	44	389	44	389

6 - bolts

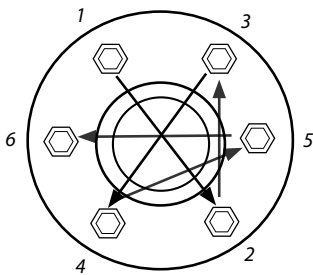

8 - bolts

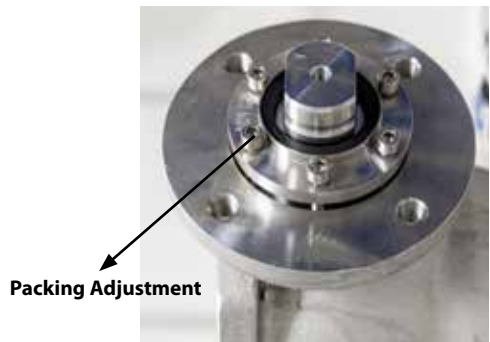
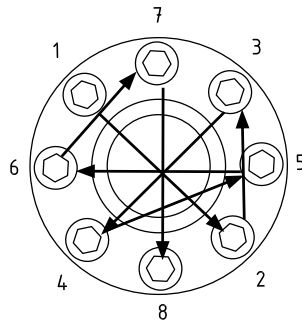

Exploded View Floating Ball Design Standard Trim

Floating Ball Design

Item	Quantity	Description	Carbon Steel		Stainless Steel	
			ASTM	DIN	ASTM	DIN
1	1	Body	A216 WCB	1.0619	A351 CF8M	1.4408
2	1	Tail	A216 WCB	1.0619	A351 CF8M	1.4408
3	1	Ball	A182 F316L+coating	1.4404+coating	A182 F316L+coating	1.4404+coating
4	1	Stem	A276 Gr.431	1.4057	A276 Gr.431	1.4057
5	1	Body gasket	PTFE/Graphite/316SS	PTFE/Graphite/1.4571	PTFE/Graphite/316Ti	PTFE/Graphite/1.4571
6	2	Seat	A182 F316L+coating	1.4404+coating	A182 F316L+coating	1.4404+coating
7	1	SX Stem seal	TFM	TFM	TFM	TFM
8	1	Packing gland	A479 316Ti; 316SS	1.4571; 1.4401	A479 316Ti; 316SS	1.4571; 1.4401
9	1	Support ring	A479 316Ti; 316SS	1.4571; 1.4401	A479 316Ti; 316SS	1.4571; 1.4401
10*	8	Stud	A193 Gr.B7	A4-70	A193 Gr.B8M Cl.2	A4-70
11*	8	Heavy hex nut	A194 Gr.2H	A4-70	A194 Gr.8M	A4-70
12	1	Spring energized lip seal	PTFE - Carbon+Graphite filled/AISI 301	PTFE-Carbon+Graphite filled/1.4310	PTFE - Carbon+Graphite filled/AISI 301	PTFE - Carbon+Graphite filled/AISI 301
13	1	Packing set	Graphite	Graphite	Graphite	Graphite
14	1	Guide bushing	PTFE - Carbon filled	PTFE - Carbon filled	PTFE - Carbon filled	PTFE - Carbon filled
21*	6	Hex socket head cap screw	A193 B8M Class 2	A4-70	A193 B8M Class 2	A4-70
40	2	Seal ring	Graphite	Graphite	Graphite	Graphite
41	1	Wave spring	17-7 PH	1.4568	17-7 PH	1.4568
42	1	S-ring	F51, A276 UNS S31803, A276 316L, A276 316 Ti	1.4462; 1.4404; 1.4571	F51, A276 UNS S31803, A276 316L, A276 316 Ti	1.4462; 1.4404; 1.4571

Item	Quantity	Description	Carbon Steel		Stainless Steel	
			ASTM	DIN	ASTM	DIN
16	2	Parallel key	316SS/316Ti	A4/1.4571	316ss/316Ti	A4/1.4571

6" class 300 floating ball design with key connection item 16
 * Quantities may differ depending on the valve size

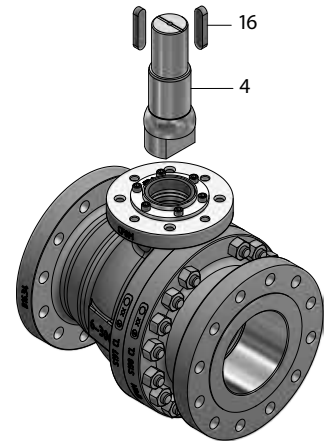
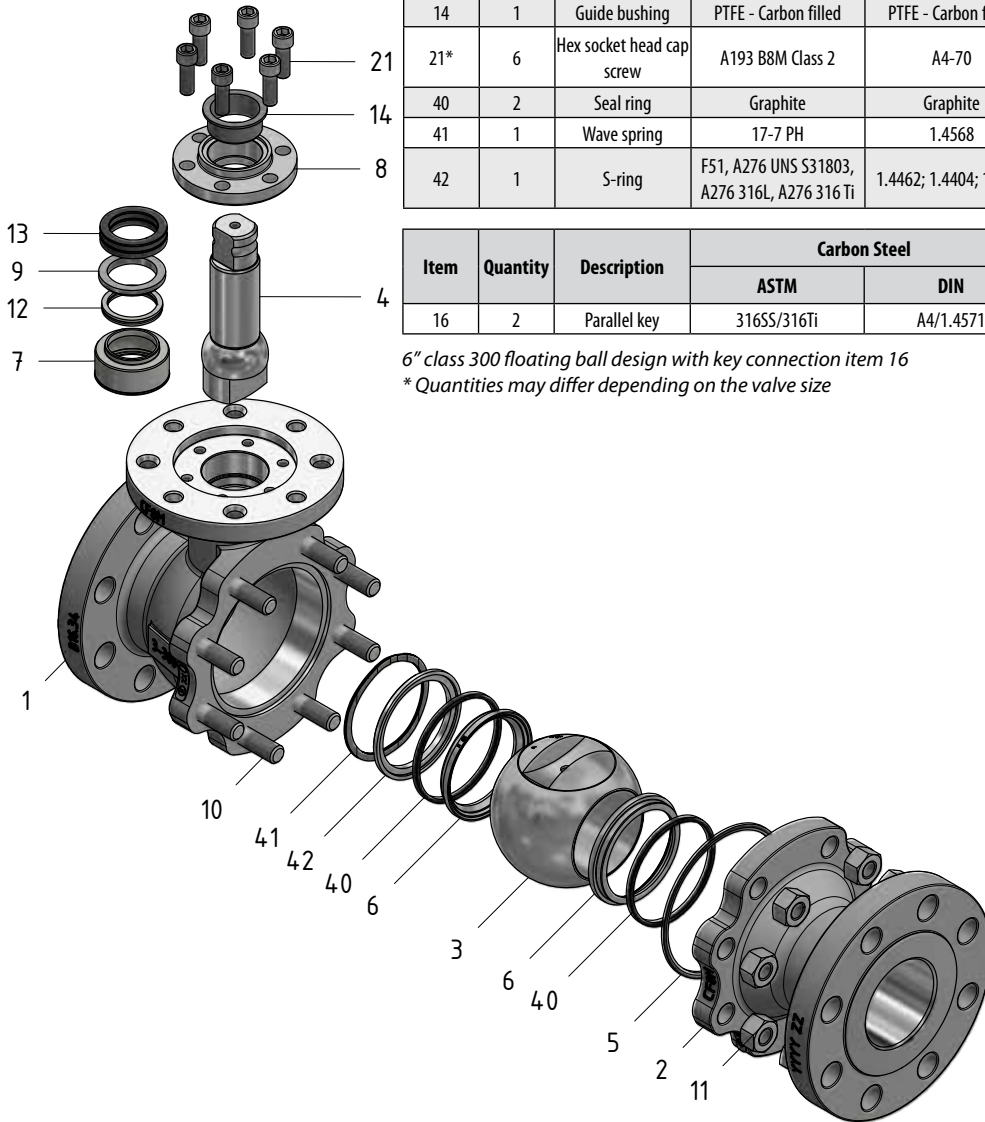

Exploded View Floating Ball Design High Temperature Trim

Floating Ball Design

Item	Quantity	Description	Carbon Steel		Stainless Steel	
			ASTM	DIN	ASTM	DIN
1	1	Body	A216 WCB	1.0619	A351 CF8M	1.4408
2	1	Tail	A216 WCB	1.0619	A351 CF8M	1.4408
3	1	Ball	A182 F316L+coating	1.4404+coating	A182 F316L+coating	1.4404+coating
4	1	Stem	A276 Gr.431	1.4057	A276 Gr.431	1.4057
5	1	Body gasket	PTFE/Graphite/316SS	PTFE/Graphite/1.4571	PTFE/Graphite/316Ti	PTFE/Graphite/1.4571
6	2	Seat	A182 F316L +coating	1.4404+coating	A182 F316L +coating	1.4404+coating
7	1	S2 Stem seal	e-Carbon	e-Carbon	e-Carbon	e-Carbon
8	1	Packing gland	A479 316Ti ; 316SS	1.4571; 1.4401	A479 316Ti ; 316SS	1.4571; 1.4401
10*	8	Stud	A193 Gr.B7	A4-70	A193 Gr.B8M Cl.2	A4-70
11*	8	Heavy hex nut	A194 Gr.2H	A4-70	A194 Gr.8M	A4-70
13	1	Packing set	Graphite	Graphite	Graphite	Graphite
14	1	Guide bushing	A582 303 coated	1.4305 coated	A582 303 coated	1.4305 coated
21*	6	Hex socket head cap screw	A193 B8M Class 2	A4-70	A193 B8M Class 2	A4-70
40	2	Seal ring	Graphite	Graphite	Graphite	Graphite
41	1	Wave spring	A286	1.4980	A286	1.4980
42	1	S-ring	F51, A276 UNS S31803, A276 316L, A276 316 Ti	1.4462; 1.4404; 1.4571	F51, A276 UNS S31803, A276 316L, A276 316 Ti	1.4462; 1.4404; 1.4571

Item	Quantity	Description	Carbon Steel		Stainless Steel	
			ASTM	DIN	ASTM	DIN
16	2	Parallel key	316SS/316Ti	A4/1.4571	316ss/316Ti	A4/1.4571

6" class 300 floating ball design with key connection item 16

* Quantities may differ depending on the valve size

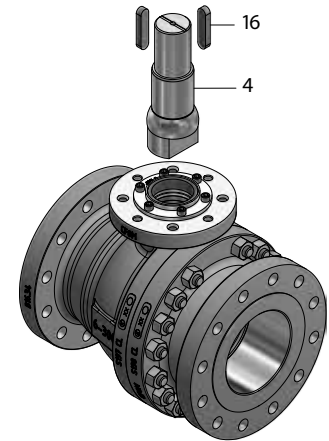
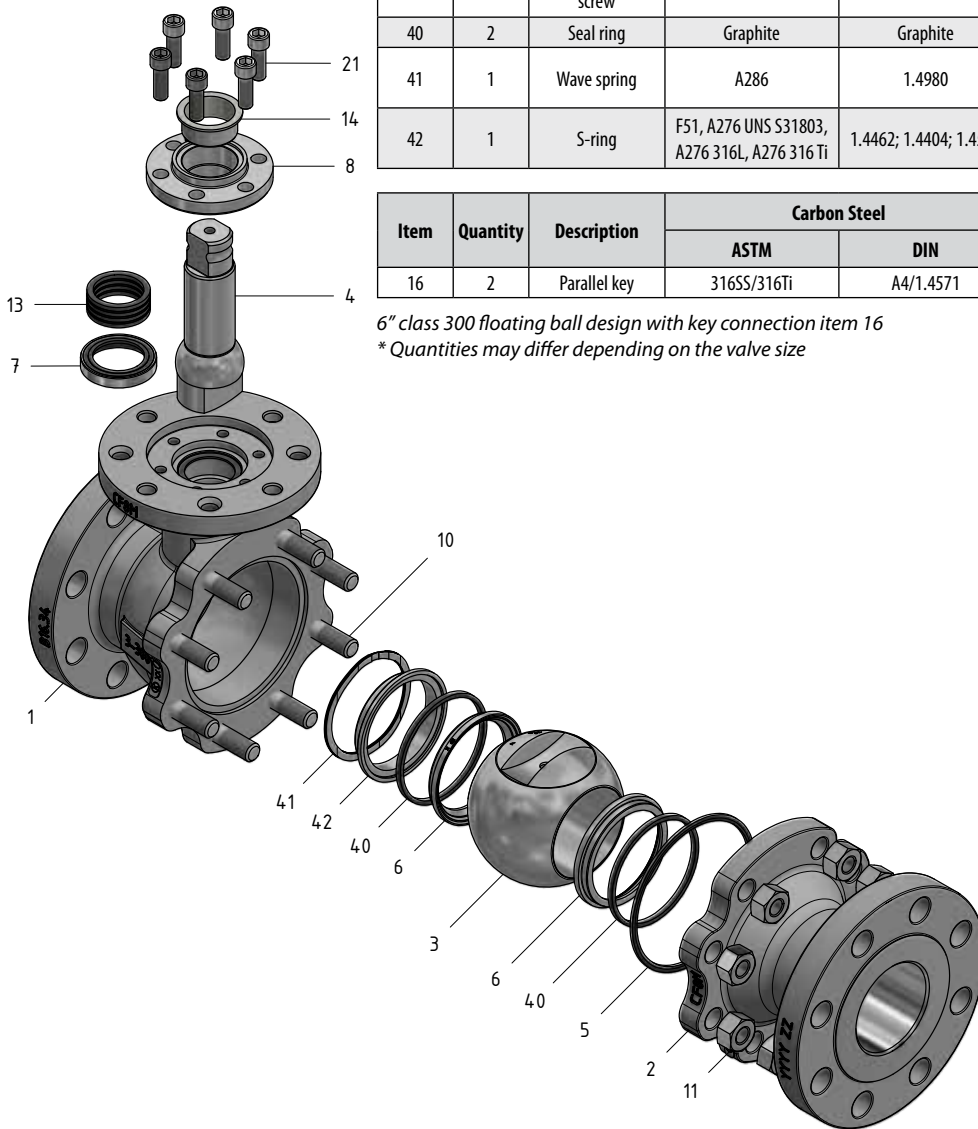

Assembly and Disassembly Instructions

DIS-ASSEMBLY

ATTENTION

If lifting tools (for example ropes) are necessary to carry the valve to the workshop the actuator should be free from heavy load and the valve and actuator must not be damaged.

ATTENTION

For shut-off valves with single-acting drives, the drive must be in the safety position for reasons of safety in order to exclude accidental switching during installation. Danger to safety!

1. Remove lever or operator from valve
2. Separate the body halves (#1 body & #2 tail) by unscrewing the body heavy hex nuts (#11)
3. Remove the body gasket (#5)
4. Rotate the ball (#3) to the closed position and remove it from the valve body
5. Rotate socket head cap screws (#21) by turning counter-clockwise & remove the packing gland (#8) from the body (#1) and stem (#4)
6. Remove the seats (#6), s-ring (#42), wave spring (#41) & seal rings (#40) from the body (#1) & tail (#2). Be careful, seat sealing surfaces should not be damaged while removing it from body (#1) & tail (#2).
7. Remove the stem (#4) by pressing it down into the body cavity
8. Remove the packing (#13), support ring (#9), spring energize lip seal (#12), and sx stem seal (#7) from the body

INSPECTION

1. Inspect the valve components for wear or damage
2. Be sure to carefully inspect the following components for nicks, cracks, breaks, or other defects: Seats (#6) • Ball (#3) • Stem (#4) • SX Stem Seal (#7) • Spring Energized Lip Seal (#12) • Packing rings (#13) • Wave spring (#41) • S-ring (#42) • Seal rings (#40) (as shown in Exploded View)
3. The parts listed above, along with the body gasket (5), are the only components that should require replacement. In addition, carefully inspect the valve body and tail.
4. Inspect the seat pockets, stem bore, packing chamber and body joint gasket areas. Clean all areas thoroughly to remove all signs of corrosion and media build-up.

RE-ASSEMBLY

When re-assembling the valve, it is recommended that new seal components be used to minimize the chance of internal and external leakage. Seal kits are available containing new seals for repairing KROMBACH TUFSEAT Performance series ball valves. The components included in each kit are indicated on the exploded view. The sealing surfaces on parts must be without surface imperfection & valve without dust or debris particles. Apply grease coating wherever required.

Note- Seal/ repair kit includes: Body Gasket (#5), SX or S2 stem seal (#7), Spring energized lip seal (#12) (if applicable), Packing set (#13), Guide bushing (#14), Seat seal rings (#40), Wiper rings (#15) (if applicable).

ATTENTION

Check the seat surface for any damage or dent marks. Replace body, if dent marks above 1mm are found.

Assembly of KFO-1176 Standard Trim Floating Ball Valve

KFO1176: Standard Trim

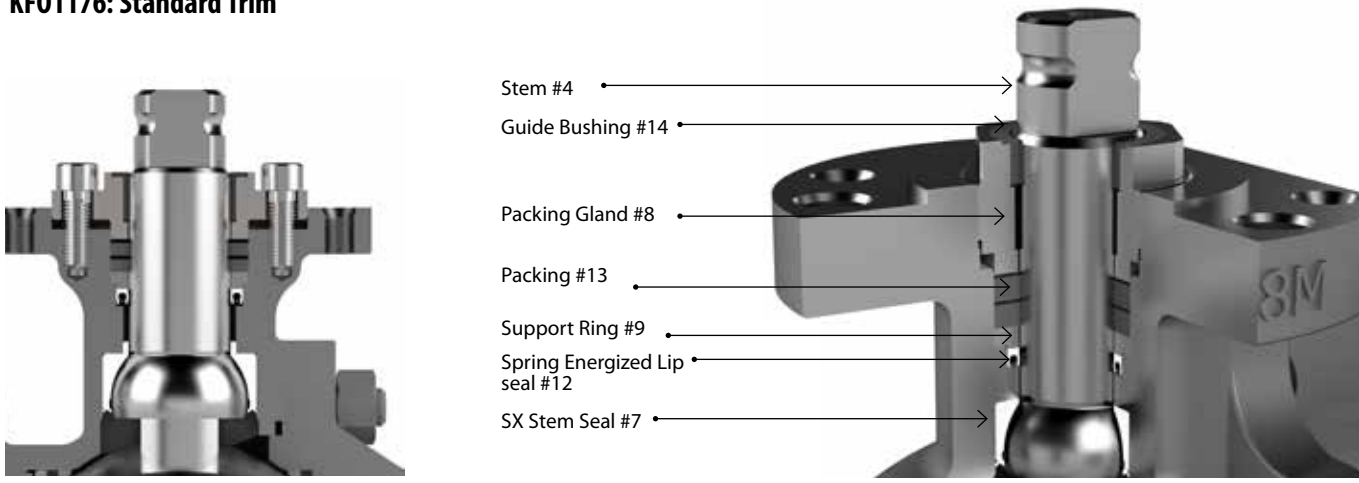

Figure 5

1. Apply castrol optimal paste on short threaded part of the studs (#10) and insert them into the body tap holes. Then tighten the studs.



3. Insert stem (#4) through the valve body cavity, allowing the SX seal (#7) to be seated into the body counter bore. (see Fig. 3).



Figure 3

2. Insert SX stem seal (#7) over the top of the stem (#4) with the conical surface facing the spherical stem shoulder (see Fig. 1), slide the SX seal over the spherical portion of the stem (see Fig. 2).



Figure 1



Figure 2

4. Place the spring energized lip seal (#12) (Fig. 4a) over the stem (#4) with the spring side facing downward into the body (as shown in Fig. 4b) and gently push into position (below the packing chamber).



Figure 4a



Figure 4b

5. Install the support ring (#9) over the stem (#4) with the raised step facing downward until it locates at the bottom of the packing chamber. (See Fig. 5).

Assembly of KFO-1176 Standard Trim Floating Ball Valve

6. Install one number of 'Graphite packing ring (thick)' & 'Diffusion barrier ring (thin) (#13) over the Stem (#4).



7. Grease contact surfaces of Gland bushing (#14) and the Packing gland (#8) and then insert them onto the stem and push the stem seals deeper into the stem chamber.



8. Apply "Castrol Optimol paste TA" on the screws (#21) and insert them into the packing gland. Slightly pre-tighten them by hand.



9. Compress the packings to the assembly compression; Tighten the screws incrementally to the torque specified on the table from Page 9 or 10.



10. Rotate the stem 5 times

NOTE: Always cycle in COUNTER-clock direction to open the ball, and in clock wise direction to close the ball.



11. Remove the packing gland along with gland bushing.



12. Repeat steps 6, 7, 8, 9 & 10, to get the stack of 4 packing rings; alternate 2 'Graphite packing rings (thick)' & 2 'Diffusion barrier rings (thin).

13. Install the Threaded Packing Gland (#8) over the valve stem:

13.1 Threaded Packing Gland Sizes: 1/2"-2" Cl.150 & 300, 3" Cl.150.

13.1.1 Rotate the Threaded Packing gland (#8) clockwise until it is lightly compressing the packing (#13).

Note: Care must be taken to not cross-thread the Threaded Packing gland (#8) and the body (#1).

Assembly of KFO-1176 Standard Trim Floating Ball Valve

Seat Assembly of KFO-1176 (Standard Trim Floating Ball Valve)

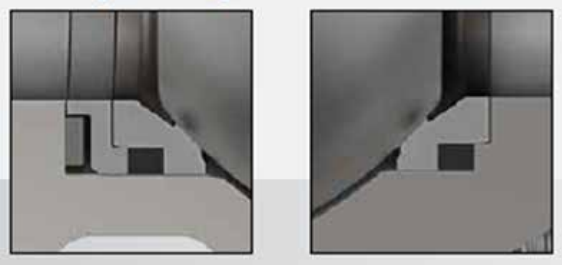

Figure 6

14. Insert Wave spring (#41) into the Body part (#1).



15. Insert S-ring (#42) into the body part (#1) over the wave spring (#41). Keep orientation of S-ring as shown in Fig.6.



16. Insert seal ring (#40) over seat "B" (#6) and insert the two together into the valve cover (or tail) (#2). Apply grease to the sealing surfaces of the seat (#6). Apply pressure and axial force to pre-compress the seat seal according to the values shown in table B.



17. Using a press, apply pressure on the seat "b" (#6) to pre-compress the seat seal. Use a plastic spacer to protect the seat and apply specified pressure. In the absence of a press, contact KROMBACH for an alternative method.

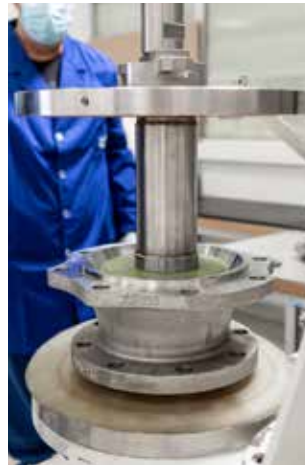

18. Insert the other seal ring (#40) over seat "A" (#6) and insert the two together into the body (#1) and over the "S" ring (#42). Apply grease to the sealing surfaces of the seat (#6). Apply pressure and axial force to pre-compress the seat seal according to the values shown in table B and in the same manner as done on the cover (tail) side.

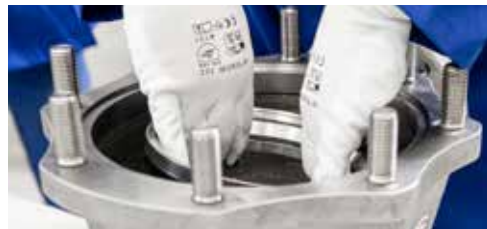

19. Insert the ball (#3) into the body cavity (#1) with the port opening in the closed position (careful not to turn the ball 180 degrees when opening and closing so that it stays as shown in the assembly drawing in accordance to ISO 5211).

Assembly of KFO-1176 Standard Trim Floating Ball Valve



20. Install spiral wound body gasket (5) in the groove of the body.



21. Join the body (#1) and tail (#2), (lettering on the halves face the same direction). install and tighten the body stud nuts in the crossing pattern shown in Figure 7.



22. Tighten the nuts to the torque values listed in table A. When tightening in the crossing pattern, cycle through the

pattern at least three (3) times to assure proper and uniform torque.

NOTE: When the valve is re-assembled, be sure the studs protrude through the nut a minimum of one (1) thread.

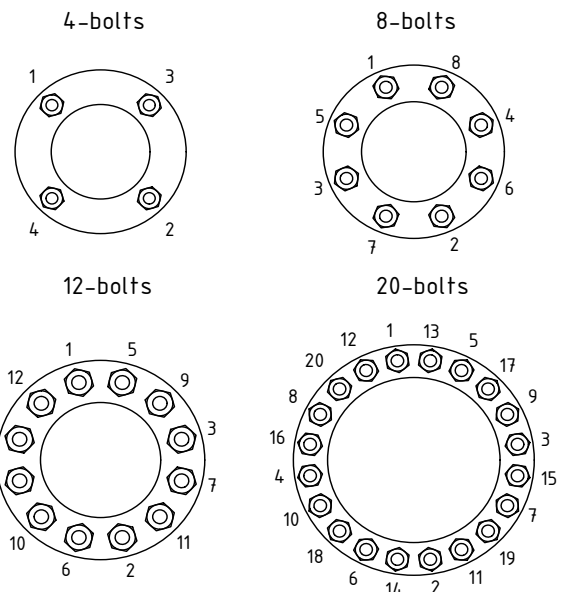

Figure 7

23. Compress the ball with a press in order to compress the "A" graphite ring. Use a plastic spacer to protect the ball.



Assembly of KFO-1156 High Temperature Trim Floating Ball Valve

KFO1156: High Temperature Trim



1. Apply Castrol Optimal paste on short threaded part of the Studs (#10) and insert them into the Body tap holes. Then tighten the Studs.



2. Insert S2 stem seal (#7) over the top of the stem (#4) with the conical surface facing the spherical stem shoulder, slide the S2 Seal over the spherical portion of the stem (see Fig. 8).



3. Insert Stem (#4) through the valve body cavity, allowing the S2 Stem Seal (#7) to be seated into the body counter bore.



4. Install one number of graphite packing ring (thick) & diffusion barrier ring (thin) (#13) over the stem (#4).



5. Grease contact surfaces of gland bushing (#14) and the packing gland (#8) and then insert them onto the stem and push the stem seals deeper into the stem chamber.



6. Apply "Castrol Optimol paste TA" on the screws and insert them into the packing gland. Slightly pre-tighten them by hand.

Assembly of KFO-1156 High Temperature Trim Floating Ball Valve



7. Compress the packings to the assembly compression; Tighten the screws incrementally to the torque specified on the table from Page 9 or 10.



8. Rotate the stem 5 times
 NOTE: Always cycle in COUNTER-clock direction to open the ball, and in clockwise direction to close the ball.



9. Remove the packing gland and the gland tube.



10. Repeat steps 4, 5, 6, 7 & 8, to get the stack of 8 packing rings; alternate 4 Graphite packing rings (thick) & 4 Diffusion barrier rings (thin).

11. Install the Threaded Packing Gland (#8) over the valve stem:

11.1 Threaded packing gland sizes: 1/2"-2" Cl.150 & 300, 3" Cl.150.

11.1.1 Rotate the press nut (#8) clockwise until it is lightly compressing the packing (#13).

Note: Care must be taken to not cross-thread the press nut (#8) and the body (#1).

Seat Assembly of KFO 1156 (High Temperature Trim)

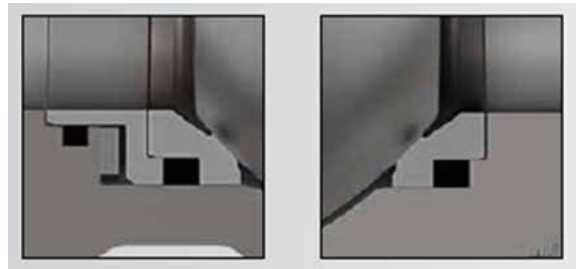

Figure 9

12. Insert wiper ring (#15) into the body part (#1) & gently push it into body groove.



13. Insert wave spring (#41) into the Body part (#1).



Assembly of KFO-1156 High Temperature Trim Floating Ball Valve

14. Insert S-ring (#42) into the body part (#1) over the wave spring (#41). Keep orientation of S-ring as shown in Fig.9.



15. Insert seal ring (#40) over seat "B" (#6) and insert the two together into the valve cover or tail (#2). Apply grease to the sealing surfaces of the seat (#6). Apply pressure and axial force to pre-compress the seat seal according to the values shown in table B.



16. Using a press, apply pressure on the seat "B" (#6) to pre-compress the seat seal. Use a plastic spacer to protect the seat and apply specified pressure. In the absence of a press, contact KROMBACH for an alternative method.

17. Insert the other seal ring (#40) over seat "B" (#6) and insert the two together into the body (#1) and over the "S" ring (#42). Apply grease to the sealing surfaces of the seat (#6). Apply pressure and axial force to pre-compress the seat seal according to the values shown in table B and in the same manner as done on the cover (tail) side.

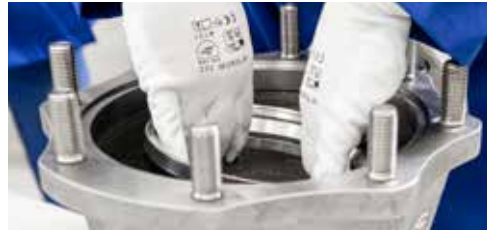

18. Careful not to turn the ball 180 degrees when opening and closing so that it stays as shown in the assembly drawing in accordance to ISO 5211.



Assembly of KFO-1156 High Temperature Trim Floating Ball Valve

19. Install spiral wound body gasket (5) in the groove of the body .



20. Join the body (#1) and tail (#2), (lettering on the halves face the same direction), Install and tighten the body stud nuts in the crossing pattern shown in figure 7.

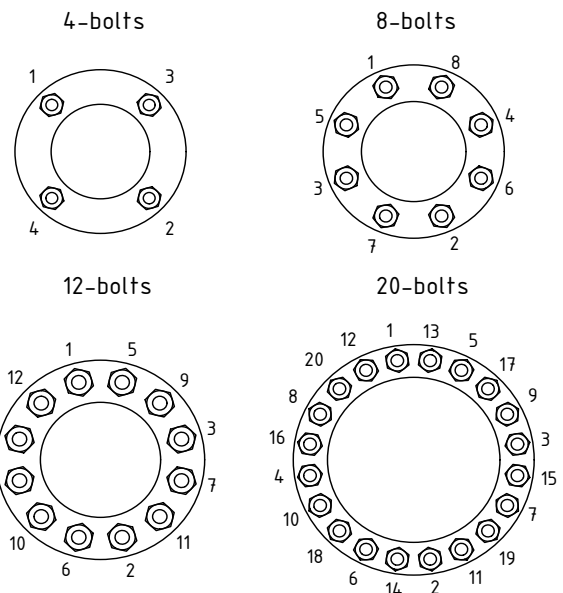

Figure 7

21. Tighten the nuts to the torque values listed in table A. When tightening in the crossing pattern, cycle through the pattern at least three (3) times to assure proper and uniform torque.

Note: When the valve is re-assembled, be sure the studs protrude through the nut a minimum of one (1) thread.

22. Compress the ball with a press in order to compress the "A" graphite ring. Use the plastic spacer for ball protection.



Instructions for Mounting Hand Lever and Locking Device

NPS ½" CL150&300 to 4" CL150 (KFO1156, 1176)

1. Insert and tighten both "stop pins" (2pcs) as shown in Figure 2.

⚠ ATTENTION

Do not over tighten Stop Pin. Excessive torque may fracture screw and could result in minor injury or property damage!

Size M6 thread, max bolt torque= 54 in-lbs or 6 Nm

Size M10 thread, max bolt torque=248 in-lbs or 28 Nm

Size M16 thread, max bolt torque=1072 in-lb or 121 Nm

2. Place hand lever on the valve as shown in (Figure 2 & 3).
 NOTE: If the stem flats are parallel with the piping, the valve is in the open position.

3. Place locking plate on hand lever as shown in Figure 2.
 Fix it behind the ear and align the hole in the locking plate with hole for SHC screw on hand lever (Figure 3).

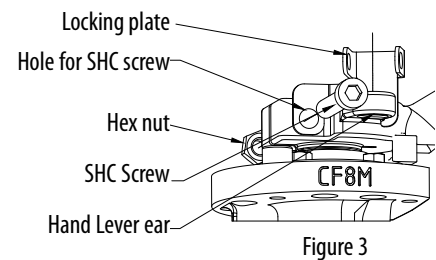
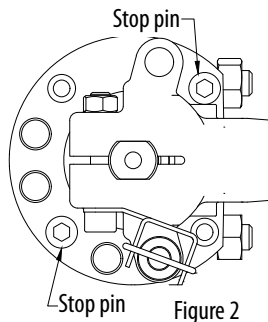
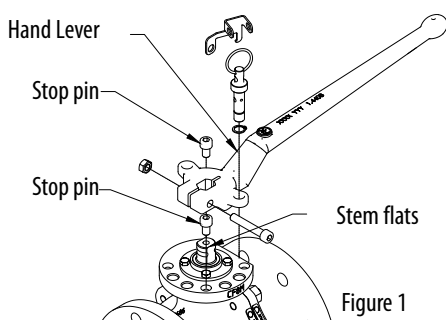
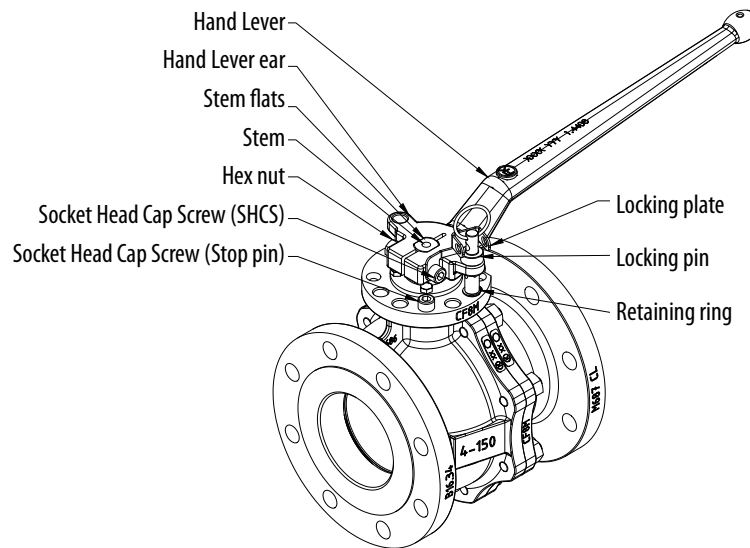

Instructions for Mounting Hand Lever and Locking Device

4. Insert the SHC screw through the locking plate hole and hand lever and tighten the hex nut until snug, clamping the hand lever to the stem flats (Figure 4).

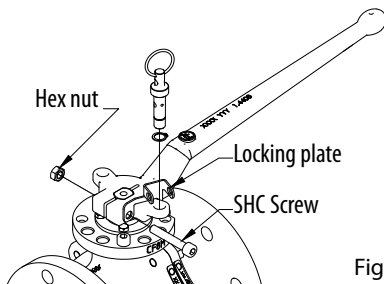

Figure 4

! ATTENTION

Do not over tighten Socket Head Cap (SHC) Screw/Hex Nut. Excessive torque may fracture screw and could result in minor injury or property damage!

Size M6 thread, max bolt torque= 54 in-lbs or 6 Nm

Size M10 thread, max bolt torque=248 in-lbs or 28 Nm

Size M16 thread, max bolt torque=1072 in-lb or 121 Nm

5. Insert locking pin thru locking pin hole on lever (Figure 4 & 5).

6. Attach the retaining ring in groove near the bottom of locking pin (Figure 5). This will assure the locking pin is attached to the lever.

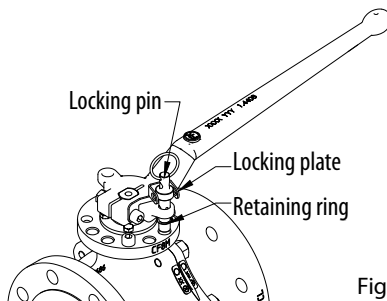

Figure 5

Installing Lockout Padlock (provided by customer)

1. Using padlock with 8 mm shank, insert shank thru the elongated hole in locking plate and hole under pull ring (Figure 6).

2. Using padlock with 6 mm shank, insert shank thru the hole in locking pin under the hand lever ear (Figure 7).

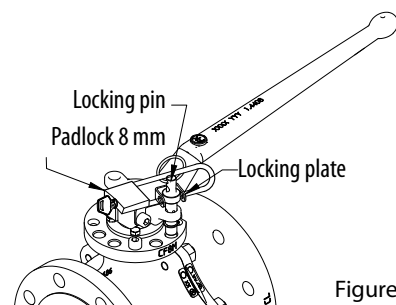

Figure 6

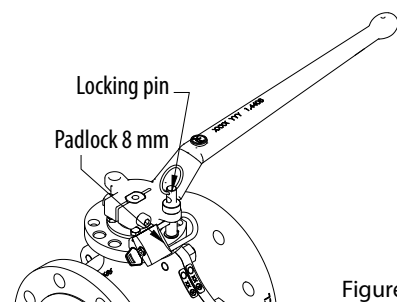

Figure 7

CRANE®

CRANE CHEMPHARMA & ENERGY

Friedrich Krombach GmbH
Armaturenwerke
Marburger Str. 364
57223 Kreuztal, Germany
Tel.: +49 2732 520 00

4526 Research Forest Drive,
Suite 400
The Woodlands
Texas 77381, U.S.A.
Tel.: +1 936 271 6500

Crane Co., and its subsidiaries cannot accept responsibility for possible errors in catalogues, brochures, other printed materials, and website information. Crane Co. reserves the right to alter its products without notice, including products already on order provided that such alteration can be made without changes being necessary in specifications already agreed. All trademarks in this material are the property of the Crane Co. or its subsidiaries. The Crane and Crane brands logotype (CENTER LINE®, COMPAC-NOZ®, CRANE®, DEPA® & ELRO®, DOPAK®, DUO-CHEK®, FLOWSEAL®, GYROLOK®, GO REGULATOR®, HOKE®, JENKINS®, KROMBACH®, NOZ-CHEK®, PACIFIC VALVES®, RESISTOFLEX®, REVO®, SAUNDERS®, STOCKHAM®, TEXAS SAMPLING®, TRIANGLE®, UNI-CHEK®, VALVES®, WESTLOCK CONTROLS®, WTA®, and XOMOX®) are registered trademarks of Crane Co. All rights reserved.