



**brands you trust.**

## OPERATION AND MAINTENANCE INSTRUCTIONS

### Krombach® KFO 9136 Metal Seated Ball Valves



**CRANE**

[www.cranecpe.com](http://www.cranecpe.com)

# Krombach® KFO 9136 Installation, Operation & Maintenance

## 1. General

### 1.1 Area of Application

This operating manual applies for ball valves produced by Friedrich Krombach GmbH Armaturenwerke.

The operating manual also applies to identical valves from other companies if these valves were delivered through Krombach and the contract documents for the delivered valves expressly mentions this operating manual. Before the valves are used, the manual must be read carefully and completely.

If there any discrepancies or if anything is unclear, please contact KROMBACH.

### 1.2 Warning of Danger

#### ATTENTION

If the following caution and warning notes are not observed, this can lead to dangerous situations and the manufacturer's warranty could become ineffective. Please contact KROMBACH if you have any queries.

#### 1.2.1 Installation, Maintenance and Operating Personnel

#### ATTENTION

To avoid endangering persons and equipment, expert staff must be used for fitting, maintenance and operation. (see DIN IEC 3/B/244/CDV)

#### 1.2.2 Carrying out fitting work on valves

#### ATTENTION

Fitting work on pressurized parts of the valve may only be carried out when the pipeline is depressurized. To prevent pressure and/or medium being trapped inside the ball valve, put the valve in the half-open position. The valve must have cooled down to ambient temperature before work is started.

#### ATTENTION

Fitting work on pressurized parts of valves for caustic or toxic flow media may only be carried out following additional emptying and bleeding of the valve and the respective pipeline.

#### ATTENTION

Caution! Valves have dead spaces where residue (under pressure) can remain after the flow medium has been emptied.

#### ATTENTION

The same safety requirements apply to valves as to the pipeline system they are built into and for the control system that is attached to the drive if appropriate. This manual only states the safety instructions that have to be heeded in addition for the valves.

#### ATTENTION

The safety instructions listed also apply to any heating sheath. The manufacturer's specifications are valid for attachment parts. The manufacturer's manuals contain additional safety instructions for the attached parts.

# Krombach® KFO 9136 Installation, Operation & Maintenance

## 1.3 Product identification and marking

### 1.3.1 General Designation

The valve must be checked for correlation with the specification after delivery, by the customer and before installation in the system.

Standard-series valves produced by Krombach are marked by:

- FK Manufacturer's mark
- DN Nominal diameter
- PN Nominal pressure in bar
- Material number for valve housing and cap/cover

### 1.3.2 Designation with type designation plate

Valves that have been designed and confirmed for special operating data have a type plate attached.

The type plate has the following marking:

- FK Manufacturer's mark
- DN Nominal diameter
- Maximum operating pressure in bar at maximum operating temperature in °C
- Bj. Model year
- Consignment no. or factory no.

### 1.3.3 CE Designation

Valves that are subject to CE marking are marked additionally by:

- CE mark
- Code of the issuing office

### 1.3.4 Valves for Oxygen

Valves for oxygen (O<sub>2</sub>) have additional markings:

- "Oil and grease-free, suitable for oxygen"

## 1.4 Condition on delivery, transport and storage

The valves are delivered with an outer coating, sealed with protective caps, and in an open position.

Valves made of stainless steel are not coated.

### ATTENTION

The valve must be stored dry in its original packaging and/or sealed with protective caps.

**Sealing surfaces and threads in particular must not be damaged mechanically or through any other factors.**

### ATTENTION

Valves for oxygen are delivered sealed in film. Shipping and storage must be carried out in such a way that the film does not become damaged. Only undamaged transport film guarantees freedom from oil and grease as packed after manufacture.

### ATTENTION

Lifting equipment must be fixed to the valve housing.

The coating, handwheel and accessory parts must not become damaged by the lifting equipment being hooked on.

Lifting equipment must not be hooked to handwheel or valve spindle. **ACCIDENT HAZARD! DAMAGE** to the product!

The valves should be stored in closed, dry rooms on a firm clean base.

# Exploded View Standard Design

## 2. Product

### 2.1 Exploded View and Materials of Construction

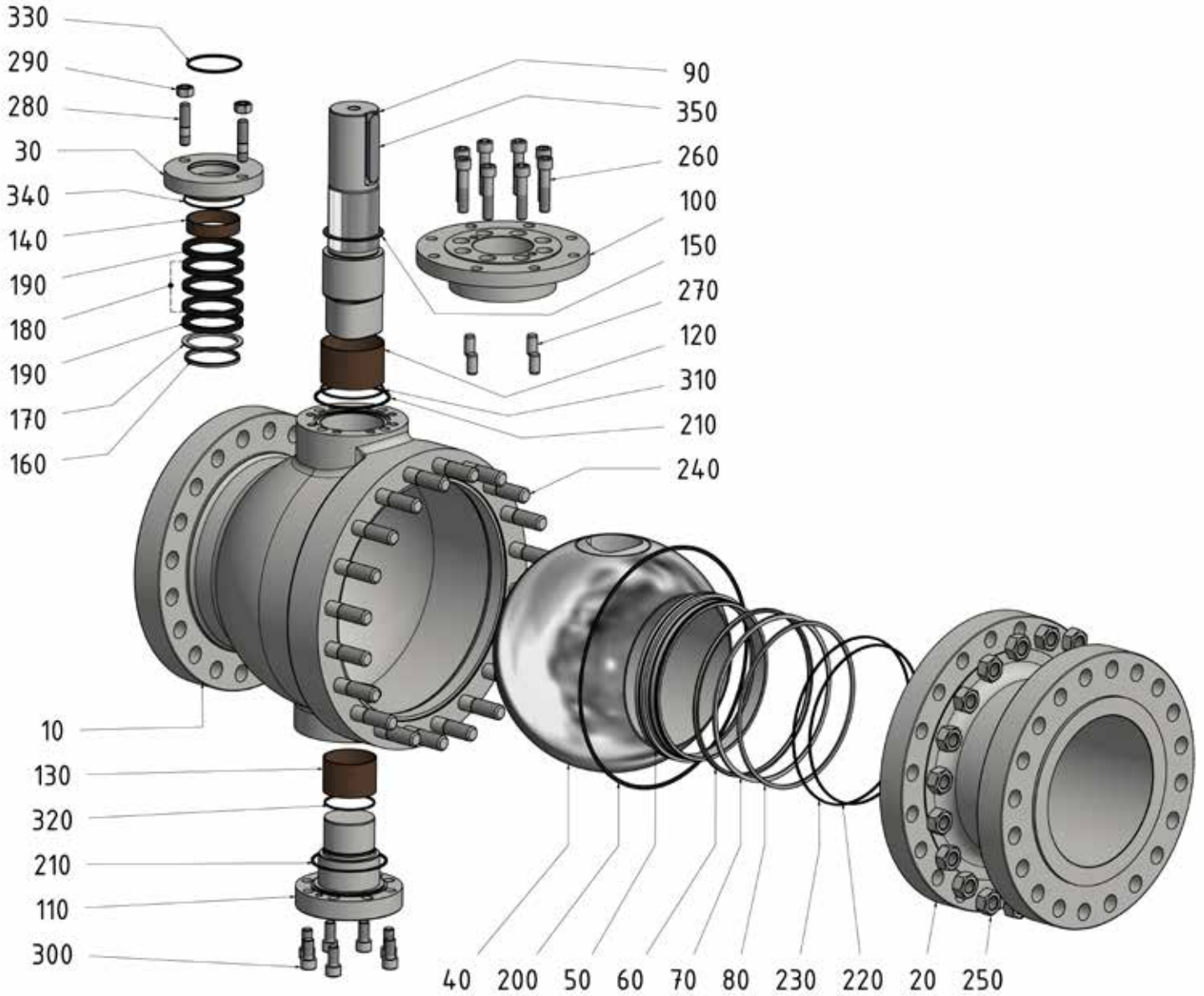

# Krombach® KFO 9136 Materials of Construction

Item*	Description	Carbon Steel		Stainless Steel	
		ASTM	DIN	ASTM	DIN
10	Body	A216 WCB	1.0619	A351 CF8M	1.4408
20	Body Cover	A216 WCB	1.0619	A351 CF8M	1.4408
30	Gland	A105	1.0460	A276 Gr. 316Ti	1.4571
40	Ball	A182 Gr. 316Ti + H4	1.4571 + H4	A182 Gr. 316Ti + H4	1.4571 + H4
50	Seat Ring	A182 Gr. 316Ti + H4	1.4571 + H4	A182 Gr. 316Ti + H4	1.4571 + H4
60	Seal Element (Seat)	PTFE-Compound / Graphite	PTFE-Compound / Graphite	PTFE-Compound / Graphite	PTFE-Compound / Graphite
70	Pressure Ring	A276 Gr. 316Ti	1.4571	A276 Gr. 316Ti	1.4571
80	Cup Spring	Inconel X718	2.4668	Inconel X718	2.4668
90	Stem	A276 Gr.420	1.4021	A182 F51	1.4462
100	Bonnet	A105	1.0460	A276 Gr. 316Ti	1.4571
110	Trunnion	A105	1.0460	A276 Gr. 316Ti	1.4571
120	Bearing	Carbon Steel +PTFE	Carbon Steel +PTFE	Stainless Steel +PTFE	Stainless Steel +PTFE
130	Bearing	Carbon Steel +PTFE	Carbon Steel +PTFE	Stainless Steel +PTFE	Stainless Steel +PTFE
140	Bearing	Carbon Steel +PTFE	Carbon Steel +PTFE	Stainless Steel +PTFE	Stainless Steel +PTFE
150	Axial Bearing	Carbon Steel +PTFE	Carbon Steel +PTFE	Stainless Steel +PTFE	Stainless Steel +PTFE
160	Sealing Ring (Stem)	PTFE-Compound / Elgiloy Spring	PTFE-Compound / Elgiloy Spring	PTFE-Compound / Elgiloy Spring	PTFE-Compound / Elgiloy Spring
170	Supporting Ring	A276 Gr. 316Ti	1.4571	A276 Gr. 316Ti	1.4571
180	Packing Ring	Graphite	Graphite	Graphite	Graphite
190	Supporting Ring	Graphite	Graphite	Graphite	Graphite
200	Gasket	Graphite	Graphite	Graphite	Graphite
210	Gasket	Graphite	Graphite	Graphite	Graphite
220	Wiper Ring	Graphite	Graphite	Graphite	Graphite
230	Wiper Ring	Graphite	Graphite	Graphite	Graphite
240	Stud Bolt	A193 Gr. B7 Zinc plated	1.7709 Zinc plated	A193 Gr. B7 Zinc plated	1.7709 Zinc plated
250	Hex. Nut	A194 Gr. 2H Zinc plated	1.7258 Zinc plated	A194 Gr. 2H Zinc plated	1.7258 Zinc plated
260	Cyl. Screw	A193 Gr. B7 Zinc plated	1.7709 Zinc plated	A193 Gr. B7 Zinc plated	1.7709 Zinc plated
270	Pin	Carbon Steel	Carbon Steel	Stainless Steel	Stainless Steel
280	Stud Bolt	A193 Gr. B7 Zinc plated	1.7709 Zinc plated	A193 Gr. B7 Zinc plated	1.7709 Zinc plated
290	Hex. Nut	A194 Gr. 2H Zinc plated	1.7258 Zinc plated	A194 Gr. 2H Zinc plated	1.7258 Zinc plated
300	Cyl. Screw	A193 Gr. B7 Zinc plated	1.7709 Zinc plated	A193 Gr. B7 Zinc plated	1.7709 Zinc plated
310	Bearing Protector	Graphite	Graphite	Graphite	Graphite
320	Bearing Protector	Graphite	Graphite	Graphite	Graphite
330	O-Ring	FKM	FKM	FKM	FKM
340	O-Ring	FKM	FKM	FKM	FKM
350	Parallel Key	A29 (1045)	1.0060	A29 (1045)	1.0060

\* Master BOM includes all items for the standard design

# Krombach® KFO 9136 Installation, Operation & Maintenance

## 2.2 Product description

### 2.2.1 Proper Use

The valves have been designed exclusively for installation into a pipeline system to block off or guide through media.

#### ATTENTION

A valve may not be used if its permissible pressure/temperature range (= "rating") is not sufficient for the operating conditions. The permitted values can be found on the valve type plate or the product data sheet. Special approval is required from KROMBACH for use of the valve outside these values.

**Disregarding this regulation can lead to danger to life and limb and cause damage in the pipeline system.**

#### ATTENTION

It must be guaranteed that the parts of the valve that come into contact with the media are made of materials suitable for the media used. KROMBACH will not accept liability for any damage caused by corrosion through aggressive media.

**Disregarding this regulation can lead to danger to life and limb and cause damage in the pipeline system.**

#### ATTENTION

For valves that are used as an end valve:  
 During normal operation, in particular with gaseous, hot and/or hazardous media, **a blind flange or cap must be fitted to the open connection** or (only suitable for short-term use!) the valve must be safely locked in the "CLOSED" position.

#### ATTENTION

If the valve has to be opened as an end valve in a pressurised line, this must be done extremely carefully so that the **medium sprayed** out does not cause any damage. Be careful when closing such a valve: Danger of crushing between housing and ball!

#### ATTENTION

If a valve has to be removed from a pipeline:  
 Medium can escape from the pipeline or the valve.  
 In the case of media that can be harmful to health or are hazardous, the pipeline has to be completely emptied before the valve is removed. Be careful of **residue that can flow out of dead spaces in the valve or the pipeline or have remained in the valve (under pressure).**

#### ATTENTION

Make sure that valves that have been operated at operating temperatures of  $> 50^{\circ}\text{C}$  or  $< 20^{\circ}\text{C}$  and the pipeline connections cannot be touched by the operator, in order to protect the operator from injury.

- The usual flow speeds analogue to EN 593:2004 Table 2 must be observed during permanent operation in the pipeline system. Abnormal operating conditions such as vibrations, pressure surges, erosion, cavitation and more than small shares of solids in the medium – in particular abrasive solids – must be clarified with KROMBACH.
- Media to be conveyed may only have a very small share of solids that can damage or block the seal system.
- The use of abrasive media is not recommended.
- The valves should not be used for media that are prone to inner deposits.
- If a valve is to be used for throttling in permanent operation, this must be agreed when the order is placed. The application limits must always be agreed with KROMBACH (cavitation-free operation!).
- The valves are not designed for swelling compressive load with large stress reversals.

### 2.2.2 Method of Operation

- Ball valves are actuated using a hand lever. (Actuation through gear/drive see 2.7.5)
- A ball with cross-hole is used as a blocking fitting, which either releases or blocks the full medium flow through a swivel movement of  $90^{\circ}$ .  
 The valve is closed by turning the hand lever to the right (clockwise).  
 The valve is opened by turning the hand lever to the left (anti-clockwise).  
 Respective instructions are on the hand lever itself.
- No torque-enhancing aids may be used to actuate the valve.

# Krombach® KFO 9136 Installation, Operation & Maintenance

## 2.2.3 Design and technical data

The technical design of the valves corresponds to the enclosed documentation.

All the dimensions, materials, special versions, accessories and any further specifications can be found in the enclosed ORDER-RELATED DOCUMENTATION.

The images under 2.1 are only design examples

## 2.3 Installation in the Pipeline

### 2.3.1 General Instructions

- Before installation in the pipeline, the valve must be checked to make sure that it matches the specification for the installation location
- Clean the valve of storage and transport dirt
- Remove the cap from the valve
- The connection pipeline and pipeline connection flanges must be parallel and the correct distance apart.
- When the system is being painted after valve installation, the stem must remain free of paint.
- When media are used at an operating temperature of under 0°C, the valve has to be dry before it is put into operation.
- Pipelines designed for steam to flow through them must be routed in such a way that condensation draining is possible and water hammers are excluded.
- If fittings are insulated, care must be taken that the stuffing box area remains accessible and controllable in the operating state.

### 2.3.2 Installation position and Direction

The ball valves can be installed in any position, but can be restricted by accessories (e.g. drives).

The normal installation position is to be preferred > stem vertically upright.

The installation position with the stem hanging downwards must be avoided because operating medium can spill over the hand lever if the stem seal is leaking.

If there is a danger of the valves freezing, only the normal installation position is permissible, and the valves must have a draining fitting in the central housing section. The mode of operation must guarantee that the valve does not become damaged by freezing medium.

### ATTENTION

Uni-directional valves need to be installed in the preferred direction as indicated by the arrow on the tag of the valve.

### ATTENTION

Where liquid media with great heat expansion and temperature fluctuations are used in the system, impermissibly high pressures can result, which place too great a strain on the pressure-loaded housing. In such cases, the valve and the pipeline must be secured against impermissibly high pressure. The dead spaces in the valve must be secured separately by means of a pressure-relief bore hole or other measures.

### ATTENTION

When the valve is installed in the pipeline, the arrow on the fitting must point in the pressure direction. Tightness in the opposite direction is not guaranteed.

### 2.3.3 Installation

- The valve has to be installed without tension in a clean pipeline.
- Before the valves are installed, check that the connection dimensions of the valve flanges or the welding ends connectors match those of the pipeline.
- The flange seals must be centred.
- The fastening screws on the connection flanges must be tightened evenly and crosswise.
- Welded valves are to be welded in place without tension, taking technical rules into account. (Welding and any heat treatment that may be necessary takes place at the responsibility of the pipeline construction company)
- The valve may not serve as an anchor in the pipeline system, it must be carried by the pipeline.

### 2.4 Commissioning

- Before the valve is put into operation, check that the correct valve has been installed in installation position according to 2.3.2.
- Check the correct position of the valve in relation to the way the system works.
- All installation work must be completed correctly before operation is started.
- Check the valve for leaks during and after it has been put into operation by means of visual inspection.



# Krombach® KFO 9136 Installation, Operation & Maintenance

## 2.5 Maintenance and Testing

### 2.5.1 Maintenance Interval

Depending on the type of system and operating data involved, the valve will need some maintenance.

The maintenance interval must be determined by the system owner-operator on the basis of his specific operational experience. In particular, airtightness and function must be checked regularly according to operational experience or legal regulations.

**⚠ ATTENTION**

**CAUTION!** Valves for the flow medium oxygen must not be allowed to come into contact with unsuitable materials, e.g. lubricants!

### 2.5.2 Testing Pressure

The testing pressure for recurring tests must not exceed the value of the testing pressure at the manufacturer's. This can be found in the valve's acceptance test certificates.

### 2.5.3 Stuffing Box on Ball Valves

- Check that the stuffing box is leakproof.
- If the stuffing box is not leakproof, tighten carefully until it is.
- Valve actuation must be guaranteed, however.
- If tightness cannot be achieved, the stuffing box packing must be replaced.

**⚠ ATTENTION**

The stuffing box packing may only be replaced when the instructions under section 1.2 + 2.8 of this operating manual are taken into account.

**⚠ ATTENTION**

The packing ring material must be resistant to the flow medium and be suitable for the respective operating data, operating pressure and operating temperature.

The special packaging instructions of the packing manufacturer must be taken into account for the different packing materials, or the valve manufacturer must be consulted if necessary.

### 2.5.4 Housing Seal / Seal Shells

Check the sealing elements for tightness. If they are not leakproof, tighten with the valve depressurised. If tightness is not achieved, a new housing seal or sealing shells must be used.

**⚠ ATTENTION**

The sealing elements must be replaced with the valve depressurised, the requirements of section 1.2 + 2.8 of this operating manual must be met.

## 2.6 Faults and Fault Rectification

- Determine and define the type of problem.
- If the problem is caused by a heavy leak, the leak spot should be localised if possible.
- Inform KROMBACH. (See Warranty section 2.9)

## 2.7 Accessories

### 2.7.1 Final Position Switch

The installed final position switches must be connected according to the respective circuit diagram and checked for correct adjustment.

### 2.7.2 Locking Fixtures

To prevent the valve being actuated unintentionally, which could lead to danger, locking and catch fixtures are available from the manufacturer.

### 2.7.3 Special Accessories and Versions

Additional specifications must be heeded for valves with special accessories or for special versions.

### 2.7.4 Valves with Gear and/or Actuator

**⚠ ATTENTION**

Special mounting, maintenance and operating instructions from the manufacturer are valid for gears and/or drives! Please contact KROMBACH if you have any queries.

**⚠ ATTENTION**

Ball valves with gear, electric/pneumatic setting drive are installed in the normal installation position: Stem vertically upright (drive at the top) in the pipeline. This installation position must be observed!  
**KROMBACH must be consulted if other installation positions are required!**



# Krombach® KFO 9136 Installation, Operation & Maintenance

- The direction of rotation  
clockwise = CLOSE;  
anti-clockwise = OPEN  
remains the same whether the valve is actuated by  
means of the gear handwheel or the electric/pneumatic  
actuating drive!

## ATTENTION

The connection of electric cables may only be carried out by specialised staff.

Applicable regulations, in particular VDE 0100 and VDE 0165 (explosion protection) must be heeded.

### 2.7.5 Retrofitting Actuators

## ATTENTION

The very wide range of operating conditions and possible installation positions must be taken into consideration in particular when retrofitting drives.

**KROMBACH must always be consulted in such cases!**

## 2.8 Repairs

Repairs and service work on valves may only be carried out by the manufacturer or trained staff, see also section 1.2.

### 2.8.1 Repairs at the Manufacturer's

- Due to increased efforts to protect the environment and the health of our employees, we need to know from you which materials the ball valves to be repaired by our employees have been in contact with.
- Our service technicians may not do any work without this contamination declaration.
- To avoid unnecessary expenditure and delay for you and us, we require your contamination declaration together with the order and shipping papers in the event of repair or replacement work (form is attached or can be requested from us).

### 2.8.2 Repairs at the Operator's

If the valve cannot be repaired at the manufacturer's, this work should be carried out by a service fitter or by trained operator staff. Only original spare parts may be used for this.

### 2.8.3 Repairs at the Operator's

A repair of balls and seat rings, by grinding and polishing, can be accomplished exclusively at the manufacturer. If this is not possible, new parts must be used from the manufacturer.

## 2.9 Guarantee

The warranty for this product is regulated by the General Terms and Conditions of the company Friedrich Krombach GmbH Armaturenwerke and with the supply contract concluded.

- During the warranty period, the valve may only be removed or opened with the approval of -KROMBACH or in the presence of a KROMBACH representative.

## 2.10 Declaration of responsibility for user safety

**NOTE - RESPONSIBILITY OF THE USER  
FAILURE OR IMPROPER SELECTION OR IMPROPER USE  
OF THE PRODUCTS OR RESPECTIVE PARTS DESCRIBED  
IN THIS MANUAL CAN CAUSE FATALITIES, INJURY OR  
PROPERTY DAMAGE.**

This document and other information from Krombach contain product or system options for further investigation through users with technical know-how.

The user is solely responsible for the final selection of system and components through examination and testing, and for making sure that all the capacity, durability, maintenance, safety and warning requirements of the application are met. The user has to examine all aspects of the application carefully, follow applicable industrial standards and heed the information related to the product in the current product catalogue as well as all other documents that are provided by Krombach.

As far as Krombach delivers components or system options based on technical data or specifications that have been provided by the user, the user is responsible for checking that these technical data and specifications are suitable and sufficient for all applications and reasonably predictable purposes of application of the systems.







# KROMBACH ARMATUREN

Crane ChemPharma & Energy

Crane ChemPharma & Energy  
4526 Research Forest Drive, Suite 400  
The Woodlands  
Texas 77381, U.S.A.  
Tel.: +1 936 271 6500  
Fax: +1 936 271 6510

Friedrich Krombach GmbH  
Armaturenwerke  
Marburger Str. 364  
57223 Kreuztal, Germany  
Tel: +49 2732 520 00  
Fax: +49 2732 520 100

[www.cranecpe.com](http://www.cranecpe.com)



## brands you trust.



COMPAC-NOZ<sup>®</sup>



DEPA<sup>®</sup>

ELRO<sup>®</sup>

DUO-CHEK<sup>®</sup>



NOZ-CHEK<sup>®</sup>



RESISTOFLEX<sup>®</sup>



Saunders<sup>®</sup>  
*the science inside*

STOCKHAM<sup>®</sup>



UNI-CHEK<sup>®</sup>

w.ta<sup>®</sup>

XOMOX<sup>®</sup>

Crane Co., and its subsidiaries cannot accept responsibility for possible errors in catalogues, brochures, other printed materials, and website information. Crane Co. reserves the right to alter its products without notice, including products already on order provided that such alteration can be made without changes being necessary in specifications already agreed. All trademarks in this material are property of the Crane Co. or its subsidiaries. The Crane and Crane brands logotype, in alphabetical order, (ALOYCO<sup>®</sup>, CENTER LINE<sup>®</sup>, COMPAC-NOZ<sup>®</sup>, CRANE<sup>®</sup>, DEPA<sup>®</sup>, DUO-CHEK<sup>®</sup>, ELRO<sup>®</sup>, FLOWSEAL<sup>®</sup>, JENKINS<sup>®</sup>, KROMBACH<sup>®</sup>, NOZ-CHEK<sup>®</sup>, PACIFIC VALVES<sup>®</sup>, RESISTOFLEX<sup>®</sup>, REVO<sup>®</sup>, SAUNDERS<sup>®</sup>, STOCKHAM<sup>®</sup>, TRIANGLE<sup>®</sup>, UNI-CHEK<sup>®</sup>, WTA<sup>®</sup>, and XOMOX<sup>®</sup>) are registered trademarks of Crane Co. All rights reserved.