

# DUO-CHEK<sup>®</sup>

brands you trust.

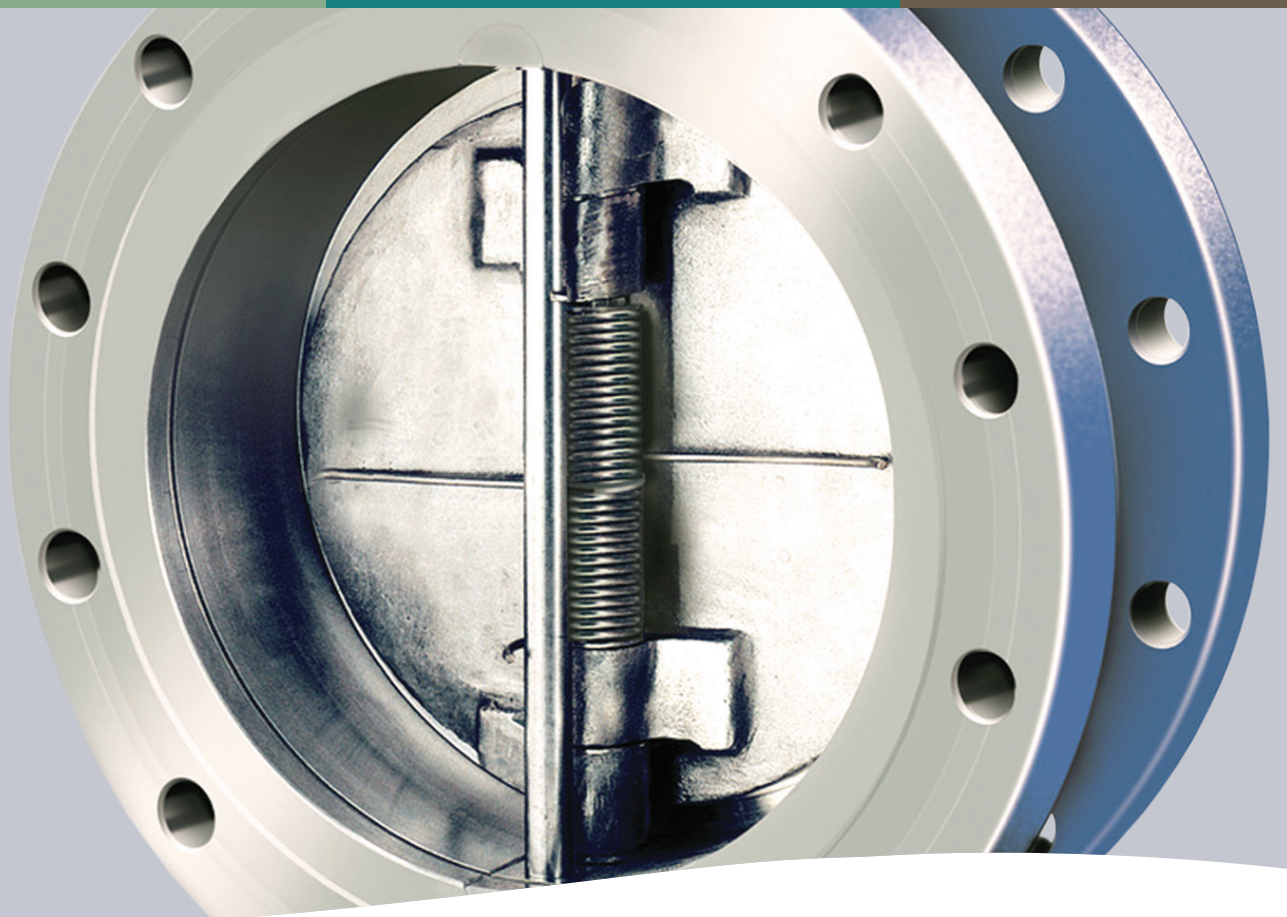

**CRANE**<sup>®</sup>

Crane ChemPharma & Energy

DUO-CHEK<sup>®</sup> High Performance  
Non-Slam Check Valves

[www.cranecpe.com](http://www.cranecpe.com)

## Key Features and Typical Applications

### Key Features & Benefits

- ❶ Dual-plate designs that are compact and lightweight for efficient seating, operation and lower installation cost
- ❷ Independent springs with long legs to prevent seat scrubbing and provide non-slam performance
- ❸ Retainerless valve design without body penetration for critical service applications

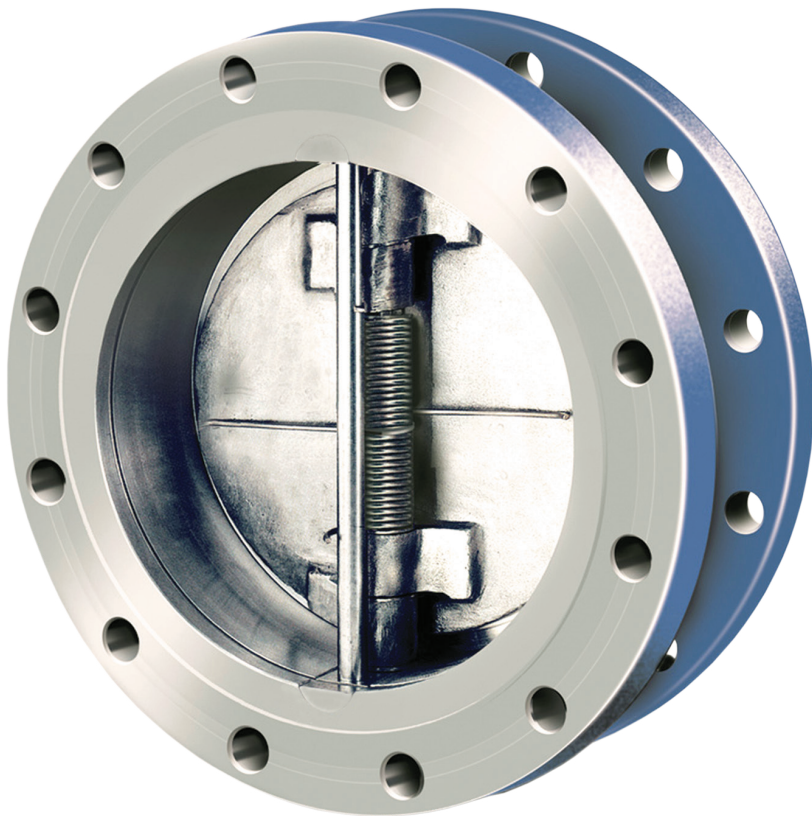

Double Flanged (Retainerless)

### Typical Applications

- Petroleum Refining
- Oil and Gas Production
- Chemicals and Petrochemicals
- Power Generation
- Steel/Primary Metals
- Marine
- Water and Wastewater
- Pulp and Paper

## Duo-Chek® The High Performance Non-Slam Check Valve

Duo-Chek® high performance non-slam check valves are the original Mission Manufacturing Company wafer check valves introduced to the market in the late 50's. The valve is available in the sizes, pressure classes and configurations required to meet the most demanding of applications. Product range includes, but is not limited to:

- Sizes: 2" to 88"
- ASME Pressure Class 125 through 2500
- API 6A and 6D pressure classes
- DIN, JIS, BS, AS, and ISO standards are also available
- Wafer, lug, double flanged and extended body styles
- Wafer configurations available in retained and retainerless style
- Body Materials:
  - Cast Iron, Carbon Steel, Stainless Steels, Duplex Stainless Steel, Super Duplex
- Resilient Seat Materials:
  - EPDM, Buna-N, Neoprene, and Viton-B®
- Integral and overlaid metal seats also available
- End Connections:
  - Raised Face, Plain Face, Ring Joint, Weld-End, Hub-End

Viton® is a registered trademark of DuPont Performance Elastomers L.L.C.

Industry Standards*	
API 594	Valve Design
API 598	Valve Pressure Testing and Inspection
ASME B16.5 & B16.47	Flanges
ASME B16.34	Pressure/Temperature Ratings
API 6D	Pipeline Valves
API 6A	Production Valves
PED 2014/68/EU	Pressure Equipment Directive

\*Consult factory for other specification requirements.

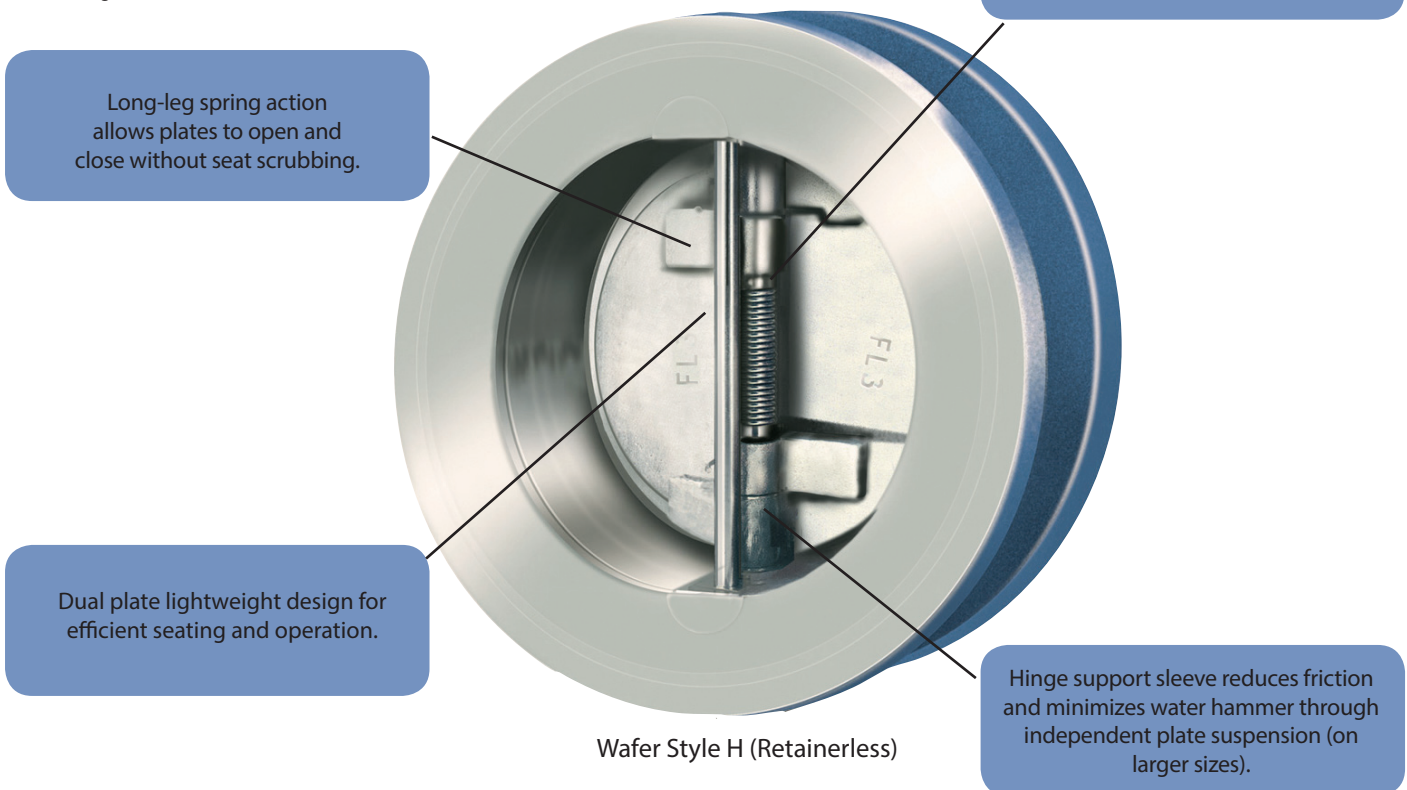

Wafer Style H (Retainerless)

## Specify Duo-Chek® ...to your Advantage

Leading engineers specify Duo-Chek® for check valve applications because it provides high performance. Extensive research and testing with demonstrated performance has earned worldwide recognition, unmatched in the industry.

The Duo-Chek® wafer valve design is generally stronger, lighter, smaller, more efficient and less expensive than conventional swing check valves. Its design meets API 594 which is approximately one fourth the face to face dimension and 15% to 20% the weight, on most popular sizes, making them less expensive than a swing check valve. It is much easier to install between standard gaskets and line flanges. The savings compound during installation due to ease of handling and only one set of flange studs is required. Therefore, it is more cost effective to install, and also to maintain.

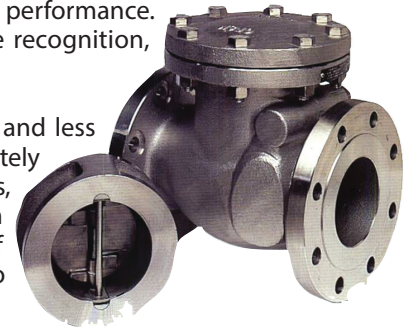

The Duo-Chek® also offers special design features that make it a high performance non-slam check valve. These include a scrub-free opening, and in most sizes a unique independent spring design as well as an independent plate support system. These features may not be found in other check valves. Other configurations offered include lug, double flange and extended body.

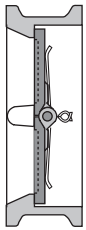

Plates in closed position. Top view.

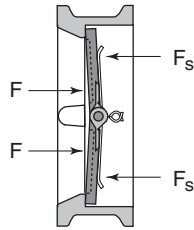

Heel opens first as flow begins.

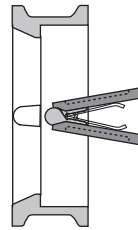

Plates fully opened (85°)

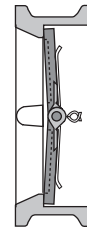
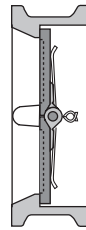

Plate toe closes first as flow decreases.



Plates fully seated for bubble-tight shutoff.

The innovative dual-plate design of the Duo-Chek® employs two spring-loaded plates (disc halves) suspended on a central vertical hinge pin. As flow begins, the plates open in response to a resultant force (F) which acts as the center of the sealed surface area. The contact point of the reacting spring leg's force (Fs) acts beyond the center of the plate area, causing the heel to open first. This prevents rubbing of the seal surface prior to normal plate opening, eliminating wear.

As the velocity of flow decreases, torsion spring action reacts automatically. This moves the plates closer to the body seats, reducing the distance and time of travel for closure. By having the plates closer to the body seats at the time of flow reversal, the valve dynamic response is greatly accelerated. This dramatically reduces the water hammer effect for non-slam performance. At closing, the point of spring force

causes the toe of the plates to close first. This prevents dragging of the heels of the plates and maintains seal integrity for much longer periods.

### Independent Spring Design

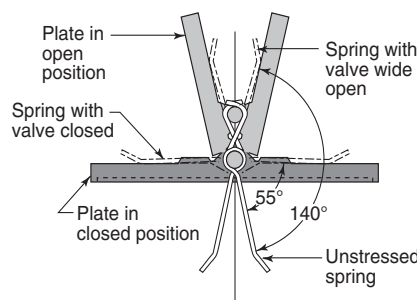

A spring design of the Duo-Chek® (sizes 6" and larger) allows higher torque to be exerted against each plate with independent closing in response to the process stream. Testing has proved this action provides up to 25% improvement in valve life and 50% reduction in water hammer.

Each of the dual plates has its own spring or springs, which provide independent closing action. These independent springs undergo less angular deflection, only 140° as compared to 350° for conventional springs with two legs.

### Independent Plate Suspension Design

The Duo-Chek® unique hinge design reduces friction forces by 66%, which improves valve response significantly. Support sleeves are inserted through the outboard hinges so that the upper hinge is independently supported by the lower sleeve during valve operation. This allows both plates to close at the same time for quick response, and excellent dynamic performance.

## Design Features

Features	Benefits
<b>Lightweight and Compact Wafer Design</b>	Installs between mating flanges with 10 to 20% the weight of flanged swing checks in popular sizes - <b>Saves money in initial valve cost and provides lower installation cost.</b>
<b>Dual Plate, Flat Seat Design</b>	Plate heel is lifted first by design to prevent seat wear. Employs two spring-loaded plates with flat seats - <b>Gives superior performance and tight shutoff to meet industry standards.</b>
<b>Independent Spring Action</b>	Maximum deflection of 140°, provides improved valve response and longer life - <b>Saves money with longer valve life and improved system performance by reducing water hammer.</b>
<b>Independent Plate Suspension with Unique Hinge Design (larger sizes)</b>	Improves valve response and reduces friction forces by 66% - <b>Further assurances of non-slam performance with faster valve response.</b>
<b>Simple, External Body Geometry</b>	Configuration simplifies valve insulation - <b>Saves money.</b>
<b>Variety of Body Designs Available Lug and Double Flange</b>	Provides options to suit application needs - <b>Eases your selection process by utilizing the industry leader as your single source.</b>
<b>Wide Variety of Materials</b>	Versatility for many services - <b>Satisfies more application needs.</b>
<b>Flexibility in Installation Position</b>	Provides more rigidity than pipe, eliminating concerns of pipe bending loads of flanged valves - <b>Safety against thermal or seismic catastrophes.</b>
<b>Body Strength and Rigidity</b>	Some sizes suitable for horizontal or vertical up positions - <b>Simplifies piping design, eliminates constraints that swing checks create.</b>
<b>Retainerless Duo-Chek® Design Eliminates Body Penetrations</b>	For critical service applications, prevents possible escape of unwanted and/or hazardous materials to atmosphere - <b>Provides safety in critical services by eliminating environmental concerns. Standards in Lug and Double Flange Designs.</b>
<b>Vertical Hinged Design</b>	In horizontal position flow allows plates to function freely and full open under lower flow conditions as compared to swing check - <b>Reduces pressure loss, improves dynamic response and eliminates valve chatter.</b>
<b>Special Valves Meet Market Needs:</b> <ul style="list-style-type: none"> <li>• Special Lined</li> <li>• Hub Ends</li> <li>• Weld Ends</li> <li>• PED Certified (CE)</li> <li>• Low Temperature Applications - Cryogenic</li> <li>• ABS Certified</li> <li>• CRN Registration</li> </ul>	Wide size range, pressure range and added options allow further market needs to be met - <b>Reliance on world's largest wafer check line to supply more needs.</b>

## Applications



A wide variety of body designs, materials, and trim make Duo-Chek® valves exceptionally versatile and suitable for a multitude of liquid and gas fluid applications.

Some of the major markets and typical applications are depicted here.



### Oil and Gas Production

- Centrifugal Compressor Discharge
- Fire Water Lines
- Oil/Steam Separation
- Steam and CO<sub>2</sub> Injection
- Gas/Oil Gathering Systems
- Flowlines
- Wellheads
- Regasification
- Liquidfaction

### Power Generation

- Steam
- Condensate
- Boiler Feed Pumps
- Cooling Towers
- Service Water Recirculators
- River Water Intake

### Petroleum Refining

- Hydrogen
- Cracking
- Steam
- Crude Oil
- Gasoline
- Visbreakers
- Naphtha
- Sulfur

### Petrochemicals

- Ethylene
- Propylene
- Steam
- Reboilers
- Gases

### Chemicals

- Chlorine
- Phosgene
- Aromatics
- Polymers
- Acids
- Air Separation
- Caustics

### Water and Wastewater

- Distribution Lines
- Pumping Stations
- Sewage Plant Blower Discharge
- Chemical Treatment
- Fire Protection Systems
- HVAC Systems
- Desalination

### Steel/Primary Metals

- Quench Lines
- De-Scaling
- Continuous Casters
- Steam
- Condensate
- Strippers
- Electro-Galvanizing

### Pulp and Paper

- Bleaching Lines
- Black Liquor
- Green Liquor
- White Water
- Steam
- Chemical Recovery

### Marine

- Oil Tankers
- Tanker Loading Terminals
- Offshore Platforms
- Sub-Sea Manifolds
- Terminal Transfer Lines
- Barge Unloading Lines
- Shipboard Services

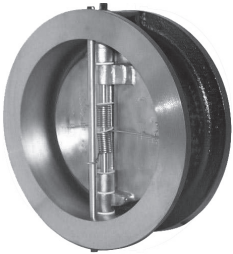

### Style G Retainered Wafer

Sizes 2" – 88"

- ASME Classes 125 – 2500
- Retainered Wafer Design
- Dimensions pages 13–14

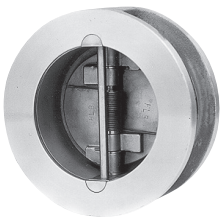

### Style H Retainerless Wafer

Sizes 2" – 88"

- ASME Classes 150 – 2500
- Dimensions pages 13–14



### Retainerless Wafer Double Flange Valves

Sizes 8" – 88"

- ASME Classes 150 – 900
- Sizes & Dimensions page 15

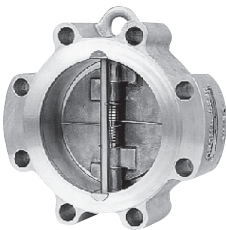

### Retainerless Wafer Lug Valves

Sizes 2" – 24"

- ASME Classes 150 – 2500
- Sizes & Dimensions page 16

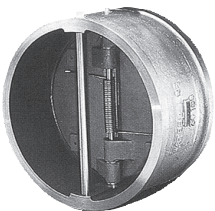

### Style X Extended Body Wafer

Sizes 10" – 54"

- ASME Classes 150 – 2500
- Designed for extremely fast opening conditions
- Sizes & Dimensions page 17

## Specials

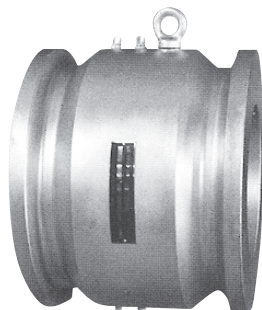

### Hub End Valves

Valves with Hub ends may be furnished for use with hub end, clamp-style connections. These end connections simplify installation procedures in systems that utilize them. Please contact your sales office for information regarding sizes and pressure ratings available, and other hub end connections such as Spolock, Seaboard Lloyd, etc.

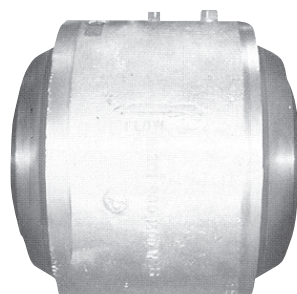

### Butt Weld Valves

Valves with butt weld ends may be furnished for piping systems designed for welded system components to eliminate potential joint leak paths. See Ordering Information for proper figure number designation, so that weld-end preparations match the mating pipe schedules.

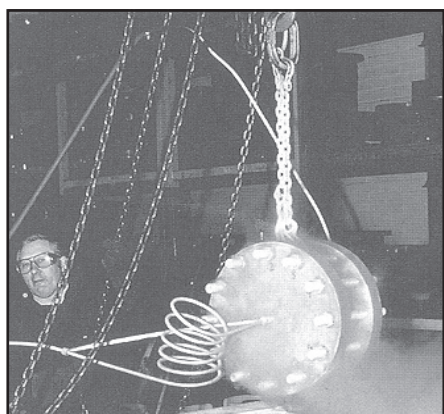

### Cryogenic Valves

Duo-Chek® valves may be furnished for subatmospheric to cryogenic temperatures -58°F through -321°F (-50°C through -196°C). Special materials of construction such as low temperature alloy steels, austenitic stainless steel, aluminum bronze or Monel® are generally required.

Monel® is a registered trademark of Special Metals Corporation.



### Coated & Lined Valves

Duo-Chek® valves may be furnished with linings, when specified, for abrasion or corrosion resistance. Linings include Natural Rubber, Neoprene, and others. All body surfaces of lined valves are covered with the specified material, eliminating the need for gaskets. Hinge and stop pin holes are encapsulated to seal them against line fluids.

Solid alloy valves are recommended for extremely corrosive applications. A variety of coatings may be provided on request to resist corrosion or abrasion. Some of the commonly specified coatings include epoxies, coal tar derivatives and sacrificial zinc primers. Please discuss your requirements with your sales office.

### Other Specials

Other Duo-Chek® specials furnished include:

- Valves to comply with NACE MR0103
- Valves cleaned for liquid oxygen (LOX) service
- Valves prepared for Food Service (austenitic stainless steel)
- Special testing for valves, including radiography, magnetic particle, dye penetrant, ultrasonic, helium leak, etc.



## Ordering Information

### Figure Number System

Size	Style	Pressure Class	Body & Plate	Seal	End Connection	Body Configuration	Modification Number
<b>24"</b>	<b>H</b>	<b>15</b>	<b>S</b>	<b>P</b>	<b>F</b>	<b>3</b> -	<b>9</b>

**DESCRIPTION:** 24" Style H, ASME Class 150, Carbon Steel Body, Metal Seal, raised face flanges, with double flange body, (modification number indicates Inconel® X spring)

Valve Size	Style		
<p>Nominal valve sizes are expressed in inches or millimeters.</p> <p><b>In Inches:</b> For use with ASME, API and B and A Flange Standards.</p> <p><b>In Millimeters:</b> For use with DIN, or JIS rated valves (size preceded by "M" for DIN, or "J" for JIS).</p>	Ordering Letter	Body Type	Size Range
	H	Retainerless Duo-Chek® Design Wafer, Lug or Double Flange	2" through 88" (50mm through 2200mm)
	G	Wafer, Retainered	2" through 88" (50mm through 2200mm)
	X	Extended Body Design	10" through 54" (150mm through 1350mm)
	W*	Bodies with Integral Weld-Ends	2" through 72" (50mm through 1800mm)

\*Weld-end valves also require the additional designation of the pipe schedule they are designed to fit.

Pressure Classes							
ASME		API <sup>Δ</sup>		DIN / JIS <sup>1</sup>		BS / AS <sup>2</sup>	
Ordering No.	Class	Ordering No.	Class	Ordering No.	PN Rating	Ordering No.	Table
12	125	21	2000	Flange Standard:	6	B - BS A - AS	A thru T
15	150				10		
25	250	31	3000	M - DIN	16		
30	300				25		
40	400	51	5000	J - JIS	40		
60	600				64		
90	900	101	10000		100		
150	1500				160		
250	2500	151	15000		250		
450	4500				320		

Δ API Class is shown in psig, cold working pressure.

1 Metric valves with DIN or JIS standard flanges are designated by having the nominal size expressed in millimeters, preceded by "M" or "J". Flange ratings in PN numbers are then listed after the valve style, as in ASME or API Valves.

### Example: M 100 (4") G16 SPF -9



This specifies a metric valve, designed to fit between DIN flanges. Nominal size is 100 millimeters (corresponding to 4"), Style G Duo-Chek® with a pressure rating of 16 bars, carbon steel body and plate, metal seal, raised face end connections and Inconel® X spring.

2 Valves designed for use with British Standard 10 or Australian Standard 2129 are defined by adding two letters between the style of construction and pressure rating. First letter designates the standard, and the second letter denotes the table in that standard.

### Example: 6" G B E 15 BNF



Figure number lists a 6" Style G Duo-Chek®, designed to fit between British Standard 10, Table E Flanges, using a Class 150 Valve, having an aluminum bronze body and plates, Neoprene seal and raised face end connections.

## Ordering Information

Body and Plates					
Ordering Letter	Material	Specifica-	Ordering Letter	Material	Specification
BA	Ni-Aluminum Bronze	ASTM B148, Alloy 958	T	317 S.S.	ASTM A351, Gr. CG-8M
C	316 Stainless Steel	ASTM A351, Gr. CF-8M	U	WC6 Alloy Steel	ASTM A217, Gr. WC6 (1¼% Cr)
F	Alloy 20	ASTM A351, Gr. CN7M	V	347 S.S.	ASTM A351, Gr. CF-8C
H	Cast Iron with Al. Br. Plates	ASTM A126, class 40	Y	C5 Alloy Steel	ASTM A217, Gr. C5 (5% Cr)
K	Hastelloy® C	ASTM B148, (952)	DZ	22% Duplex	ASTM A995, Gr. 4A
L	C12 Alloy Steel	A494, Gr. CW12MW	EA	254 SMO Stainless	UNS S31254, (ASTM CK3MCuN)
M	Monel®	ASTM A217, Gr. C12 (9% Cr)	GC	LCC Low Temp. Steel	ASTM A352, Gr. LCC
S	Carbon Steel	ASTM A494, Gr. M30C	TT	Titanium	ASTM B367, Gr. C2
		ASTM A216, Gr. WCB	EB	25% Super Duplex	ASTM A995, Gr 6A

Hastelloy® C is a registered trademark of Haynes International, Inc.

Seal <sup>1</sup>				End Connections		Special Body Configurations	
Ordering Letter	Material	Operating Temperature		Ordering Letter	Connections	Designation No.	Configuration
		°C	°F				
A	EPDM	-18 to 121	0 to 250	F	Serrated face	None (Blank)	Wafer Style, inserted between mating flanges with studs spanning entire length Lug design w/threaded holes bolted from each end Lug design with through-bolt holes to protect studs Double flanged design with valve flanges bolted to individual line flanges
M	Buna-N	-30 to 121	-22 to 250	G	Hub End	1	
N	Neoprene	-40 to 121	-40 to 250	P	Plain Face (non serrated, Class 125)	2	
P	As Body	-196 to 538	-321 to 1000	R	Ring Joint	3	
V	Viton-B®	-20 to 204	-4 to 400	W	Weld-End		
Spring Selection Guide <sup>2</sup>							
Spring Material	Operating Temperature						
	°C	°F					
Type 316 S.S.	-200 to 300	-325 to 570					
Inconel® X-750 (standard)	-200 to 370	-325 to 700					
Inconel® X-750 (heat treated)*	-200 up to 550	-325 to 1000					

\* Available upon request

1 This range of operating temperatures is for general guidance. The range varies with application, body and plate material.

2 For unique service conditions other spring materials are available. Please consult factory.

Common Modifications			
Mod No.	Material Description	API Trim No.*	Trim Description
-9	Inconel® X-750 Springs		
-14	316 S.S. Plate, Pins		
-39	410 S.S. Plate, Pins & Inconel® X-750 Springs		
-169	410 S.S. Plate, Pins, Inconel® X-750 Springs and 410 S.S. Overlay Seat	1	Type 410 S.S.
-201	316 S.S. Plate, Pins, Inconel® X-750 Springs		
-233	316 S.S. Plate, Pins, Inconel® X-750 Springs and 316 S.S. Overlay Seat	10	Type 316 S.S.
-491	Hard Face Plate, 316 SS, Pins, Inconel® X-750 Springs and Hard Face Seat	5	Hard Faced Seats
-559	Inconel® X-750 Spring and conformance to NACE MR0103		
-772	Monel® Plate, Pins, Springs, Bearings and Monel® Overlay Seat	9	Monel®
131E	410 S. S. Plate, pins, Inconel X-750 Springs and Hard Face Seat	8	F6 and Hard Faced
385E	316 S.S. Plate, Pins, Inconel X-750 Springs and Hard Face Seat	12	316 and Hard Faced

\*Steel and steel alloy based metals.

NACE MR0103 compliance offered on metal seated valves only.

## Additional Engineered Check Products



### Noz-Chek®

#### Full Body Nozzle Check Valves

- Sizes 2" – 84"
- ASME Classes 150 – 4500
- Flanged, Hub-End, Weld-End
- Iron, Steel, and Stainless Steel
- ASME, DIN, JIS Standards



### Uni-Chek®

#### Single-Disc Check Valves

- Sizes 2" – 36"
- ASME Classes 125 – 300
- Flanged, Plain, or Serrated Ends
- Cast Iron, Carbon Steel, and Stainless Steel
- Variety of external shaft options available



### Compac-Noz®

#### Compact Body Nozzle Check Valves

- Sizes 12" – 60"
- ASME Classes 150 – 4500
- Flanged, Hub-End, Weld-End
- Iron, Steel, and Stainless Steel
- ASME, DIN, JIS Standards



### Krombach®

#### Steam Extraction Check Valves

- Sizes 6" – 72"
- ASME Classes 150 – 300
- Double Flanged & Butt Weld Ends
- Steel, Stainless Steel and Welded Design

# DUO-CHEK®

Crane ChemPharma & Energy

Crane ChemPharma & Energy Headquarters  
4526 Research Forest Drive, Suite 400  
The Woodlands, Texas 77381 U.S.A.  
Tel.: (1) 936-271-6500  
Fax.: (1) 936-271-6510

Belfast, Northern Ireland Operations  
6 Alexander Road  
Cregagh, Belfast Bt6 9HJ Ireland  
Tel.: (442) 890-704222  
Fax.: (442) 890-401582

[www.cranecpe.com](http://www.cranecpe.com)

**CRANE**

## Regional Manufacturing Sites

### INDIA

Solitaire 6th Floor, Survey No. 131/1+2  
ITI Road, Opp. Reliance Footprint  
Aundh, Pune 411007, India  
Tel: 91 21 62244417  
Fax: 91 21 62245126

### AUSTRALIA

146-154 Dunheved Circuit  
St. Mary's NSW 2760  
Tel: (61) 2-8889-0100  
Fax: (61) 2-9673-3870

### AMERICAS

Xomox Chihuahua, S.A.  
Juan Ruiz de Alarcón 313,  
Complejo Industrial  
Chihuahua,  
31136 Chihuahua, Mexico  
Tel.: +52 614 442 9860

### EUROPE

6 Alexander Road  
Cregagh, Belfast BT6 9HJ  
Tel: 44 (28) 9070 4222  
Fax: 44 (28) 9040 1582

## brands you trust.



COMPAC-NOZ®

CRANE

DEPA®

ELRO® DUO-CHEK®



NOZ-CHEK®



RESISTOFLEX®



Saunders®  
the science inside

STOCKHAM®



UNI-CHEK®

Wta®

XOMOX®

Crane Co., and its subsidiaries cannot accept responsibility for possible errors in catalogues, brochures, other printed materials, and website information. Crane Co. reserves the right to alter its products without notice, including products already on order provided that such alteration can be made without changes being necessary in specifications already agreed. All trademarks in this material are property of the Crane Co. or its subsidiaries. The Crane and Crane brands logotype, in alphabetical order, (ALOYCO®, CENTER LINE®, COMPAC-NOZ®, CRANE®, DEPA®, DUO-CHEK®, ELRO®, FLOWSEAL®, JENKINS®, KROMBACH®, NOZ-CHEK®, PACIFIC VALVES®, RESISTOFLEX®, REVO®, SAUNDERS®, STOCKHAM®, TRIANGLE®, UNI-CHEK®, WTA®, and XOMOX®) are registered trademarks of Crane Co. All rights reserved.