

Duo-CHEK[®]

TECHNICAL DATASHEET

Duo-Chek[®]
Cryogenic Check Valves



Crane ChemPharma & Energy

www.cranecpe.com

Retainerless Check Valves

Style P[†]

High Performance Check Valve for Critical Applications



For critical applications, Duo-Chek[®] Retainerless Check valves Style P feature a one-piece body with no pin retainer penetration through the body.

These high performance valves utilize the same internal design as other Duo-Chek[®] valves with all the unique features and advantages built into them. The photo shown is a wafer valve however, the valve are also available in lug and double flanged.

Item No.	Part No.
1	Body
2	Plate
3	Seal
4	Stop Pin
5	Hinge Pin
6	Spring*
7	Pin Insert
8	Snap Ring

* Independent spring in valve sizes 6" and larger.

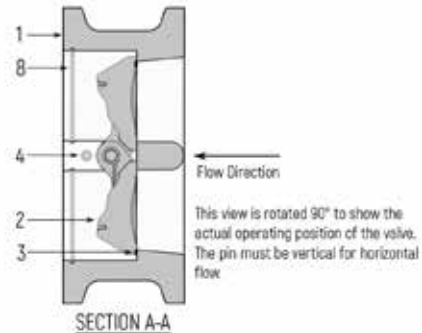
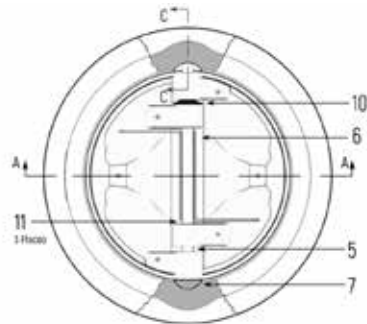

Duo-Chek[®] Retainerless Check valves have no body penetrations, potential leak paths through the valve are eliminated. This makes the Retainerless Check ideally suited to meet the following critical service applications:

- LNG
- Mixed Refrigerant
- Ethylene Production
- Ethylene Mixed Refrigeration
- Air Separation Units

Key features of the Duo-Chek[®] Retainerless Check valve Style H include:

- Sizes: 2" to 36"
- ASME pressure classes 150 to 600
- Wafer, lug and double flanged
- Typical body materials include Stainless Steels and Aluminum bronze

[†] Installation dimensions for these valves are as shown on pages 10-13.

The advanced design of the Duo-Chek Cryogenic provides many operational benefits to the user. Its' light weight compact design combined with the redesigned plates enable this valve to perform at a wide range of temperatures and pressures.

Advantages include:

- Resigned plate design allows a controlled deflection to maintain a seal across a wide range of temperatures and pressures
- Independent Plate Suspension ensuring non-slam performance with faster valve response
- Retainerless design eliminates body penetrations offering zero fugitive emissions
- Free release flat seats
- Designed using FEA and CFD technologies and proven in our in house testing facility.
- Fire Safe Design

Wafer Style P (Retainerless)

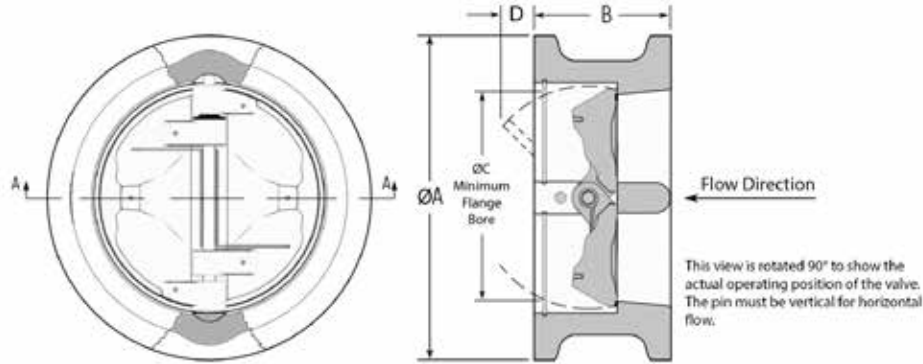

Wafer body valves are designed with flangeless bodies with short face-to-face dimensions per API 594. They are clamped between mating flanges which are connected by studs and nuts.

ASME Class 150

Size		A [OD]		B [F/F]		C		D		Weight	
in	mm	in	mm	in	mm	in	mm	in	mm	lbs.	kg.
2"	50	4 1/8	105	2 3/8	60	1.50	38	0.25	6	6	3
2 1/2"	65	4 7/8	124	2 5/8	67	0	0	0	0	10	5
3"	80	5 3/8	137	2 7/8	73	2.63	67	0.50	13	13	6
4"	100	6 7/8	175	2 7/8	73	3.50	89	0.44	11	17	8
5"	125	7 3/4	197	3 3/8	86	0	0	0	0	27	12
6"	150	8 3/4	222	3 7/8	98	5.75	146	0.50	13	35	16
8"	200	11	279	5	127	7.06	179	1.13	29	70	32
10"	250	13 3/8	340	5 3/4	146	9.31	236	1.13	29	106	48
12"	300	16 1/8	410	7 1/8	181	10.75	273	1.25	32	172	78
14"	350	17 3/4	451	7 1/4	184	12.75	324	1.50	38	200	91
16"	400	20 1/4	514	7 1/2	191	14.25	362	1.75	44	275	125
18"	450	21 5/8	549	8	203	16.75	425	2.00	51	315	143
20"	500	23 7/8	606	8 5/8	219	18.50	470	1.88	48	435	197
24"	600	28 1/4	718	8 3/4	222	21.31	541	2.25	57	620	281
26"	650	30 1/2	755	14	356	0	0	0	0	1047	476
28"	700	32 3/4	832	12	305	0	0	0	0	964	438
30"	750	34 3/4	883	12	305	27.25	692	2.75	70	719	327
32"	800	37	939	14	356	0	0	0	0	1111	505
36"	900	41 1/4	1048	14 1/2	387	31.50	800	4.00	102	1489	677

Duo-Chek® Cryogenic valves are available in accordance with DIN, BS, JIS, AS and ISO Dimensions. For other sizes and pressure classes contact factory.

Dimensions

Wafer Style P (Retainerless)

ASME Class 300

Size		A [OD]		B [F/F]		C		D		Weight	
in	mm	in	mm	in	mm	in	mm	in	mm	lbs.	kg.
2"	50	4.38	111	2.38	60	1.63	41	0.25	6	7	3
3"	80	5.88	149	2.88	73	2.63	67	0.50	13	15	7
4"	100	7.13	181	2.88	73	3.50	89	0.44	11	18	8
6"	150	9.88	251	3.88	98	5.75	146	0.50	13	45	20
8"	200	12.13	308	5.00	127	7.63	194	1.13	29	82	37
10"	250	14.25	362	5.75	146	9.31	236	1.13	29	125	57
12"	300	16.63	422	7.13	181	10.75	273	1.25	32	200	91
14"	350	19.13	486	8.75	222	12.31	313	1.38	35	325	147
16"	400	21.25	540	9.13	232	14.31	363	1.50	38	415	188
18"	450	23.50	597	10.38	264	16.50	419	2.25	57	555	252
20"	500	25.75	654	11.50	292	17.50	445	1.75	44	725	329
24"	600	30.50	755	12.50	318	20.25	514	2.00	51	1100	499
30"	750	37.50	953	15.69	368	27.25	692	3.00	76	2050	930
36"	900	44.00	1118	19.25	483	31.50	800	4.00	102	3573	1621

ASME Class 600

Size		A [OD]		B [F/F]		C		D		Weight	
in	mm	in	mm	in	mm	in	mm	in	mm	lbs.	kg.
2"	50	4.38	111	2.38	60	1.63	41	0.25	6	7	3
3"	80	5.88	149	2.88	73	2.63	67	0.50	13	15	7
4"	100	7.63	194	3.13	79	3.63	92	0.44	11	26	12
6"	150	10.50	267	5.38	136	4.25	108	0.44	11	80	36
8"	200	12.63	321	6.50	165	7.25	184	0.88	22	135	61
10"	250	15.75	400	8.38	213	8.31	211	0.88	22	238	108
12"	300	18.00	457	9.00	229	10.75	273	1.25	32	333	151
14"	350	19.38	492	10.75	273	11.50	292	1.50	38	455	206
16"	400	22.25	565	12.00	305	13.63	346	1.88	48	640	290
18"	450	24.13	613	14.25	362	14.00	356	1.50	38	890	404
20"	500	26.88	683	14.50	368	16.50	419	1.75	44	1120	508
24"	600	31.13	791	17.25	438	19.25	489	2.00	51	2040	925
30"	750	38.25	972	18.88	398	27.00	686	27.00	686	3375	1531
36"	900	44.50	1130	25.00	635	31.31	795	4.00	102	6300	2858

♦These G Style valve dimensions do not meet API 594, please consult factory.

Style P Double Flange Retainerless

Double Flanged Style Valves bolt up similar to a bolted cap swing check or gate valve. Double flanged versions are offered as standard on larger size valves where the lay length of the body permits installation of two heavy nuts between the flanges. These valves are standard retainerless design.

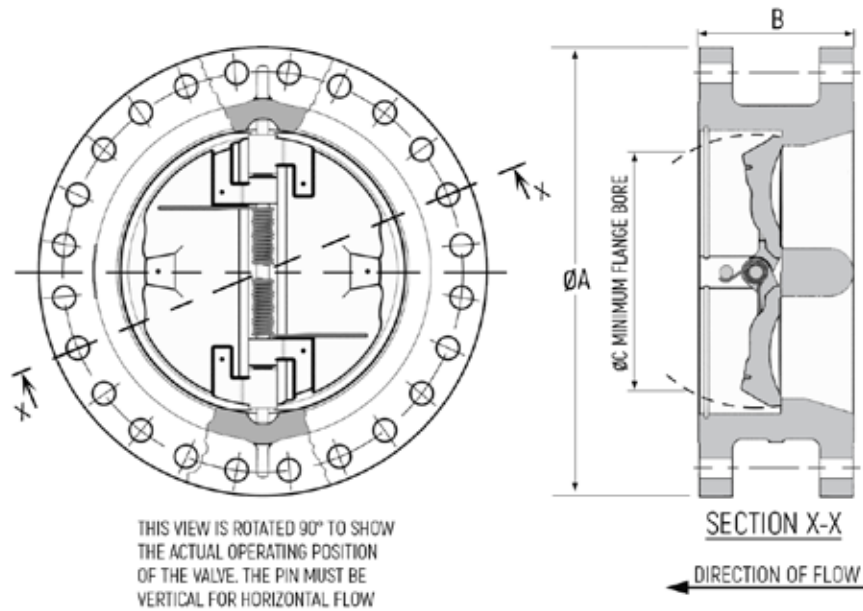

ASME Class 150

Size		A [OD]		B [F/F]		C		Weight	
in	mm	in	mm	in	mm	in	mm	lbs.	kg.
2"	50	6.00	152	4.50	114	0.50	12	15	7
3"	80	7.50	191	4.75	121	1.00	27	24	11
4"	100	9.00	229	4.75	121	3.43	87	35	16
6"	150	11.00	279	5.13	130	4.29	109	59	27
8"	200	13.50	343	5.00	127	7.63	194	93	42
10"	250	16.00	406	5.75	146	9.56	243	189	86
12"	300	19.00	483	7.13	181	11.38	289	308	140
14"	350	21.00	533	7.25	184	24.00	318	352	160
16"	400	23.50	597	7.50	191	15.00	381	496	225
18"	450	25.00	635	8.00	203	16.88	428	551	250
20"	500	27.50	699	8.63	219	18.88	480	661	300
24"	600	32.00	813	8.75	222	22.63	575	860	389
30"	750	38.75	984	12.00	305	29.25	743	1512	687
36"	900	46.00	1168	14.50	368	35.00	889	2525	1145

Dimensions

ASME Class 300

Size		A [OD]		B [F/F]		C		Weight	
in	mm	in	mm	in	mm	in	in	lbs.	kg.
2"	50	6.50	165	4.50	114	0.80	20	18	8
3"	80	8.25	210	4.75	121	1.88	48	35	16
4"	100	10.00	254	4.78	121	3.43	87	53	24
6"	150	12.50	318	5.12	130	5.67	145	88	40
8"	200	15.00	381	6.00	152	7.63	199	141	64
10"	250	17.50	445	7.00	178	7.85	243	249	113
12"	300	20.50	521	7.13	181	11.38	289	320	145
14"	350	23.00	284	8.75	222	12.50	318	593	269
16"	400	25.50	648	9.13	232	14.38	365	771	350
18"	450	28.00	711	10.38	264	16.13	409	970	440
20"	500	30.50	775	11.50	292	17.88	454	1078	488
24"	600	36.00	914	12.50	318	22.13	562	1516	686
30"	750	43.00	1092	14.50	368	28.75	730	3100	1406
36"	900	50.00	1270	19.00	483	35.00	864	4650	2109

Notes:

- Please consult factory for other sizes and pressure classes available.
- Consult factory for dimensions and weights not shown.

ASME Class 600

Size		A [OD]		B [F/F]		C		Weight	
in	mm	in	mm	in	mm	in	in	lbs.	kg.
2"	50	6.50	165	4.75	121	0.48	12	22	10
3"	80	8.25	210	5.63	143	2.25	57	62	28
4"	100	10.75	273	6.50	165	3.60	91	81	37
6"	150	14.00	356	7.63	194	5.94	151	165	75
8"	200	16.50	419	8.63	219	7.72	196	253	115
10"	250	20.00	508	9.63	244	9.75	248	427	194
12"	300	22.00	559	9.00	229	11.38	289	612	277
14"	350	23.75	603	10.75	273	12.50	318	826	375
16"	400	27.00	685	12.00	305	14.38	365	951	430
18"	450	29.25	743	14.25	362	16.13	409	1433	650
20"	500	32.00	813	14.50	368	18.00	457	1763	800
24"	600	37.00	940	17.25	438	21.56	548	2755	1250
30"	750	44.50	1130	19.88	505	28.75	730	5070	2300
36"	900	51.75	1314	25.00	635	33.75	857	7605	3450
42"	1050	55.25	1403	27.58	701	39.50	1003	9985	4529

Style P Lug Retainerless

Lug Style valves cover the bolting the entire length of the body. Lug valves are furnished in scallop and full body designs. Scallop is furnished whenever possible to keep weight to a minimum. These valves are standard retainerless design. Lug valves are furnished with thru-hole bolting in accordance with API 594. Threaded bolt holes are available but non standard as valve is not designed nor should be used for dead-end service.

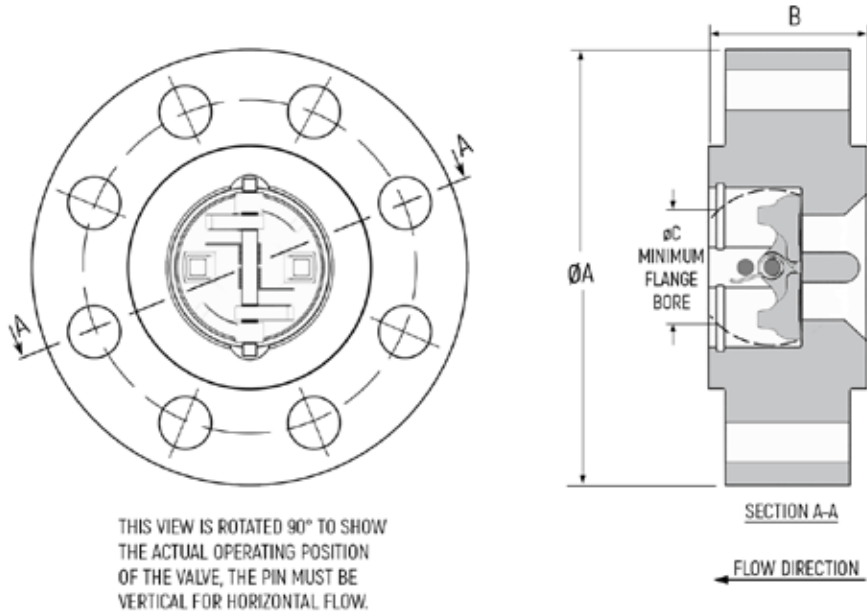

ASME Class 150

Size		A		B		C		Weight	
in	mm	in	mm	in	mm	in	mm	lbs.	kg.
2"	50	6	152	2 3/8	60	1 15/16	49	17	8
2 1/2"	65	7	178	2 5/8	67	2 11/32	60	17	8
3"	80	7 1/2	191	2 7/8	73	2 29/32	74	44	20
4"	100	9	229	2 7/8	73	3 53/64	97	44	20
5"	125	10	254	3 3/8	86	4 13/16	122	48 1/2	22
6"	150	11	279	3 7/8	98	5 49/64	146	77	35

ASME Class 300

Size		A		B		C		Weight	
in	mm	in	mm	in	mm	in	mm	lbs.	kg.
2"	50	6 1/2	165	2 3/8	60	1 15/16	49	18	8
2 1/2"	65	7 1/2	191	2 5/8	67	2 11/32	60	22	10
3"	80	8 1/4	210	2 7/8	73	2 29/32	74	30	14
4"	100	10	254	2 7/8	73	3 53/64	97	44	20
5"	125	11	279	3 3/8	86	4 13/16	122	51	23
6"	150	12 1/2	318	3 7/8	98	5 49/64	146	84	38
8"	200	15	381	5	127	7 5/8	194	163	74
10"	250	17 1/2	445	5 3/4	146	9 9/16	243	270	123

ASME Class 600

Size		A		B		C		Weight	
in	mm	in	mm	in	mm	in	mm	lbs.	kg.
2"	50	6 1/2	165	2 3/8	60	1 15/16	49	18	8
2 1/2"	65	7 1/2	191	2 5/8	67	2 11/32	60	22	10
3"	80	8 1/4	210	2 7/8	73	2 29/32	74	30	14
4"	100	10 3/4	273	3 1/8	79	3 53/64	97	60	27
6"	150	14	356	5 3/8	136	5 49/64	146	183	83
8"	200	16 1/2	419	6 1/2	165	7 5/8	194	295	134
10"	250	20	508	8 3/8	213	9 9/16	243	540	245

• Consult factory for additional sizes and pressure classes.

Din Wafer Valve Outside Diameter Of Body

PN 6, 10, 16 (ASME Class 150)

Size		PN	A (DIN)*	
in	mm		mm	in
2"	50	6	98	3 ^{27/32}
		10	109	4 ^{9/32}
		16	109	4 ^{9/32}
2 1/2"	65	6	118	4 ^{5/8}
		10	129	5 ^{1/16}
		16	129	5 ^{1/16}
3"	80	6	134	5 ^{1/4}
		10	144	5 ^{21/32}
		16	144	5 ^{21/32}
4"	100	6	154	6 ^{1/16}
		10	164	6 ^{7/16}
		16	164	6 ^{7/16}
5"	125	6	184	7 ^{7/32}
		10	194	7 ^{5/8}
		16	194	7 ^{5/8}
6"	150	6	209	8 ^{7/32}
		10	220	8 ^{21/32}
		16	220	8 ^{21/32}
8"	200	6	264	10 ^{3/8}
		10	275	10 ^{13/16}
		16	275	10 ^{13/16}
10"	250	6	319	12 ^{17/32}
		10	330	13
		16	331	13 ^{1/32}
12"	300	6	375	14 ^{3/4}
		10	380	14 ^{15/16}
		16	386	15 ^{3/16}
14"	350	6	425	16 ^{23/32}
		10	440	17 ^{5/16}
		16	446	17 ^{17/32}
16"	400	6	475	18 ^{11/16}
		10	491	19 ^{5/16}
		16	498	19 ^{19/32}
18"	450	10	541	21 ^{9/32}
		16	558	21
20"	500	6	580	22 ^{13/16}
		10	596	23 ^{7/16}
		16	620	24 ^{13/16}

PN 6, 10, 16 (ASME Class 150)

Size		PN	A (DIN)*	
in	mm		mm	in
24"	600	6	681	26 ^{25/32}
		10	698	27 ^{15/32}
		16	737	29
28"	700	6	786	30 ^{15/16}
		10	813	32
		16	807	31 ^{3/4}
32"	800	6	893	35 ^{5/32}
		10	920	36 ^{7/32}
		16	914	35 ^{15/16}
36"	900	6	993	39 ^{3/32}
		10	1020	40 ^{5/32}
		16	1014	39 ^{29/32}

PN 25, 40 (ASME Class 300)

Size		PN	A (DIN)*	
in	mm		mm	in
2"	50	25	109	4 ^{9/32}
		40	109	4 ^{9/32}
2 1/2"	65	25	129	5 ^{1/16}
		40	129	5 ^{1/16}
3"	80	25	144	5 ^{21/32}
		40	144	5 ^{21/32}
4"	100	25	170	6 ^{11/16}
		40	170	6 ^{11/16}
5"	125	25	196	7 ^{11/16}
		40	196	7 ^{11/16}
6"	150	25	226	8 ^{7/8}
		40	226	8 ^{7/8}
8"	200	25	286	11 ^{1/4}
		40	293	11 ^{17/32}
10"	250	25	343	13 ^{1/2}
		40	355	13 ^{31/32}
12"	300	25	403	15 ^{27/32}
		40	420	16 ^{17/32}
14"	350	25	460	18 ^{3/32}
		40	477	18 ^{3/4}
16"	400	25	517	20 ^{11/32}
		40	549	21 ^{19/32}
18"	450	40	574	22 ^{19/32}
		25	627	24 ^{11/16}
20"	500	40	631	24 ^{13/16}
		25	734	28 ^{7/8}
24"	600	25	734	28 ^{7/8}
		40	750	29 ^{1/2}

PN 64, 100 (ASME Class 600)

Size		PN	A (DIN)*	
in	mm		mm	in
2"	50	64	115	4 ^{1/2}
		100	121	4 ^{3/4}
2 1/2"	65	64	140	5 ^{1/2}
		100	146	5 ^{3/4}
3"	80	64	150	5 ^{29/32}
		100	156	6 ^{1/8}
4"	100	64	176	6 ^{29/32}
		100	183	7 ^{3/16}
5"	125	64	213	8 ^{3/8}
		100	220	8 ^{27/32}
6"	150	64	250	9 ^{13/16}
		100	260	10 ^{7/32}
8"	200	64	312	12 ^{9/32}
		100	327	12 ^{27/32}
10"	250	64	367	14 ^{7/16}
		100	394	15 ^{1/2}
12"	300	64	427	16 ^{25/32}
		100	461	18 ^{1/8}
14"	350	64	489	19 ^{1/4}
		100	515	20 ^{1/4}
16"	400	64	546	21 ^{15/32}
		100	575	22 ^{5/8}
20"	500	64	660	25 ^{31/32}
		100	708	27 ^{27/32}
24"	600	64	768	30 ^{7/32}
		100	819	32 ^{7/32}

***Dimension A applies to drawing on page 13. Other dimensions for ASME Classes shown apply to these valves with DIN outside diameters.**

Wafer Styles P (Retainerless)

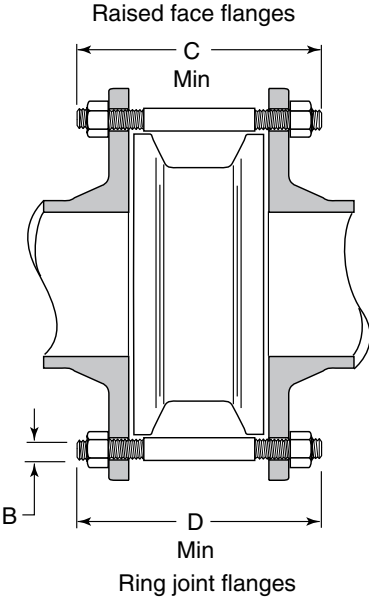

ASME Class 150

Valve Size		No. of Studs	B Bolt Diameter		C Raised Face		D Ring Joint	
in	mm		in	mm	in	mm	in	mm
2"	50	4	5/8	16	5 3/4	146	6 1/4	159
2"	1/2"	65	4	5/8	16	6 1/4	159	178
3"	80	4	5/8	16	6 3/4	171	7 1/4	184
4"	100	8	5/8	16	6 3/4	171	7 1/4	184
5"	125	8	5/8	19	7 1/2	191	8	203
6"	150	8	3/4	19	8	203	8 1/2	216
8"	200	8	3/4	19	9 1/2	241	10	254
10"	250	12	7/8	22	10 1/2	267	11	279
12"	300	12	7/8	22	12	305	12 1/2	318
14"	350	12	1	25	12 3/4	324	13 1/4	337
16"	400	16	1	25	13 1/4	337	13 3/4	349
18"	450	16	1 1/8	29	14 1/4	362	14 3/4	375
20"	500	20	1 1/8	29	15	381	15 1/2	394
24"	600	20	1 1/4	32	15 3/4	400	16 1/4	413
26"	650	24	1 1/4	32	22 3/4	578	23 1/4	591
30"	750	28	1 1/4	32	21 1/4	540	22 3/4	578
36"	900	32	1 1/2	38	26 1/4	667	29	679

Stud dimensions apply to styles G & H for Lug style thru-hole bolting design.

ASME Class 600

Valve Size		No. of Studs	B Bolt Diameter		C Raised Face		D Ring Joint	
in	mm		in	mm	in	mm	in	mm
2"	50	8	5/8	16	6 3/4	171	7	178
2 1/2"	65	8	3/4	19	7 1/2	191	7 3/4	197
3"	80	8	3/4	19	8	203	8 1/4	210
4"	100	8	7/8	22	9 1/4	235	9 1/4	235
5"	125	8	1	25	10 3/4	273	11	279
6"	150	12	1	25	12 1/4	311	12 1/2	318
8"	200	12	1 1/8	29	14 1/4	362	14 1/2	368
10"	250	16	1 1/4	32	17	432	17 1/4	438
12"	300	20	1 1/4	32	18	457	18	457
14"	350	20	1 3/8	35	20 1/4	514	20 1/2	521
16"	400	20	1 1/2	38	22 1/4	565	22 1/2	572
18"	450	20	1 5/8	41	25 1/4	641	25 1/2	648
20"	500	24	1 5/8	41	26	660	26 1/4	667
24"	600	24	1 7/8	48	30 1/4	768	30 3/4	781
26"	650	28	1 7/8	48	31 1/4	800	32	813
30"	750	28	2	51	34 1/4	870	34 3/4	883
36"	900	28	2 1/2	64	41	1041	20 1/2	1060
42"	1050	28	2 3/4	70	47	1194	47 1/2	1207

Stud dimensions apply to for Lug style thru-hole bolting design.

CRANE

CRANE CHEMPHARMA & ENERGY

4526 Research Forest Drive,
Suite 400
The Woodlands
Texas 77381, U.S.A.
Tel: +1 936 271 6500

Crane Stockham Valve Ltd.
6 Alexander Road
Cregagh, Belfast BT6 9HJ,
Northern Ireland
Tel: +44 2 890 704222

Sydney, Australia Operations
146-154 Dunheved Circuit
St. Marys, NSW 2760 Australia
Tel: +61 2 9623 0234

Xomox Chihuahua, S.A.
Juan Ruiz de Alarcón 313,
Complejo Industrial Chihuahua,
31136 Chihuahua, Mexico
Tel: +52 614 442 9860

Crane Process Flow Technologies (India) Ltd
E7 / E8 -2 Old MIDC
Satara - 415 004 India
Tel: +91 2162 244417

Crane Co., and its subsidiaries cannot accept responsibility for possible errors in catalogues, brochures, other printed materials, and website information. Crane Co. reserves the right to alter its products without notice, including products already on order provided that such alteration can be made without changes being necessary in specifications already agreed. All trademarks in this material are the property of the Crane Co. or its subsidiaries. The Crane and Crane brands logotype (CENTER LINE®, COMPAC-NOZ®, CRANE®, DEPA® & ELRO®, DOPAK®, DUO-CHEK®, FLOWSEAL®, GYROLOK®, GO REGULATOR®, HOKE®, JENKINS®, KROMBACH®, NOZ-CHEK®, PACIFIC VALVES®, RESISTOFLEX®, REVO®, SAUNDERS®, STOCKHAM®, TEXAS SAMPLING®, TRIANGLE®, UNI-CHEK®, VALVES®, WESTLOCK CONTROLS®, WTA®, and XOMOX®) are registered trademarks of Crane Co. All rights reserved.