



**TECHNISCHES  
DATENBLATT  
AUSFÜHRUNG NACH ASME**

**CRANE® FK-TrieX™  
Dreifach-exzentrische Absperrklappen  
mit vollem Durchgang für  
anspruchsvolle Anwendungen**

HOHER CV-WERT ERMÖGLICHT VERRINGERUNG DES  
LEITUNGSDURCHMESSERS

**CRANE**<sup>®</sup>

**v in** [www.cranecpe.com](http://www.cranecpe.com)

## Wesentliche Merkmale und Vorteile

### CRANE® FK-TRIEXTM - Dreifach-exzentrische Absperrklappen mit vollem Durchgang für anspruchsvolle Anwendungen

CRANE® FK-TrieXTM ist eine Armatur mit innovativer Bauform und einem maximalen Stellweg von nur einer Viertelumdrehung. Mit ihrem branchenweit niedrigsten Durchflusswiderstand überzeugt diese Absperrklappe durch einen blasendichten Abschluss und überzeugt darüber hinaus durch höchste Zuverlässigkeit und beispiellos geringer Gesamtbetriebskosten.

#### STANDARDAUSFÜHRUNG

- API-6D und API 598 kompatibel
- Leckagefreie Abdichtung
- Piggable (molchbar) gemäß Abschnitt 6.2.1
- Schutz gegen den Austritt flüchtiger Emissionen nach ISO 15848-1 AH CO3 & API 641
- Fire-Safe-Ausführung nach API 607
- ASME B16.10 Doppelflansch lange Bauform – Kugelhahn
- Hohlraumfreie Konstruktion mit Selbstreinigungseffekt
- Vakuumgeeignet
- Integrierter Montageflansch nach ISO 5211
- Druckfeste Lagerausführung

#### OPTIONALE AUSFÜHRUNG

- Heizmantel
- Ausführung gemäß NACE MR0175 / MR0103
- Doppelt zertifiziert nach CE/PED

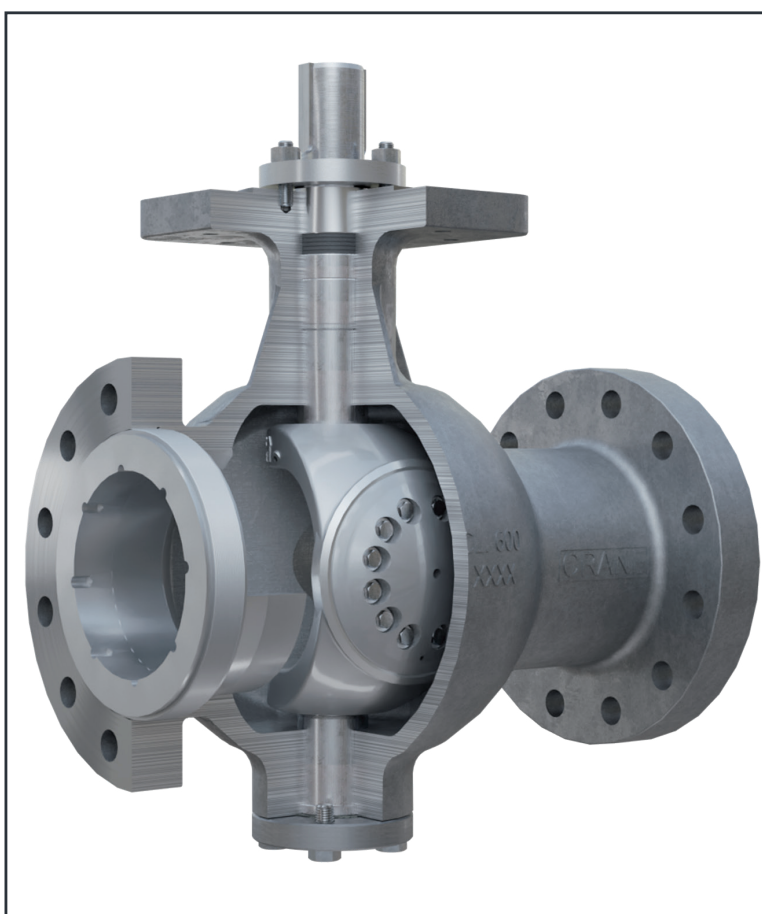

#### Produktpalette

Größe	Class	Gehäuseausführung	Baulänge	Gehäusewerkstoff
6"-36" DN 150-900	Class 150-600	Einteiliges Gehäuse Doppelflansch, lang	ASME B16.10 Lange Bauform (Kugelhahn)	WCB / 1.0619 CF8M / 1.4408



# Explosionsdarstellung

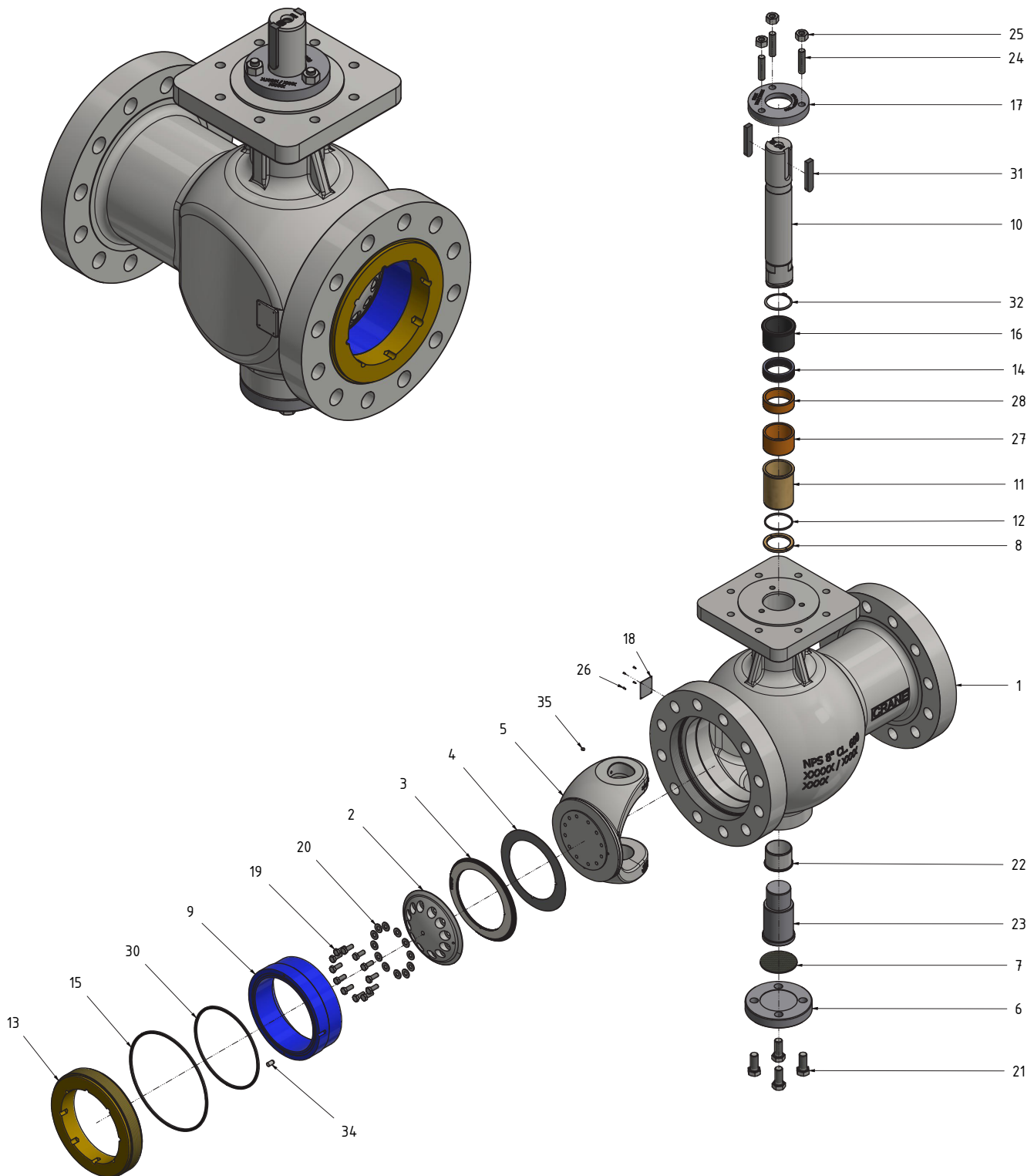

# Lieferbare Werkstoffe

Position	Bezeichnung	Stahlguss max. 700°F / 371°C*		Edelstahl max. 700°F / 371°C*	
		ASTM	DIN	ASTM	DIN
1	Gehäuse	A216 Gr.WCB	1,0619	A351 Gr CF8M	1,4408
2	Dichtungsstützring	A515 Gr.60	1,0425	A240 Gr.321	1,4541
3	Lamellendichtung	S31803/Graphit	1.4462/Graphit	S31803/Graphit	1.4462/Graphit
4	Abschlussdichtung	Graphit			
5	Scheibe	A216 Gr.WCB	1,0619	A351 Gr CF8M	1,4408
6	Deckel	A516 Gr.60/A105	1,0425	A240 Gr.321	1,4541
7	Deckeldichtung	Graphit			
8	Sicherungsring	A182 Gr. F51	1,4462	A182 Gr. F51	1,4462
9	TriëX-Ring	A105 / A216 Gr. WCB	1.0482 / 1.0619	A182-F316/ A351 Gr CF8M	1,4408
10	Welle	A564 Gr. 630 (17-4 PH)	1,4542	A564 Gr. 630 (17-4 PH)	1,4542
11	Lager	A582 Gr.303 beschichtet	1,4305 beschichtet	A582 Gr.303 beschichtet	1,4305 beschichtet
12	Lagerschutz	Graphit			
13	Einsatz	A105 / A216 Gr. WCB	1.0482 / 1.0619	A182-F316/ A351 Gr CF8M	1,4408
14	Packung	Graphit			
15	C-Ring	Inconel 718	Inconel 718	Inconel 718	Inconel 718
16	Stopfbuchse	A582 Gr.303	1,4305	A582 Gr.303	1,4305
17	Stopfbuchsflansch	A516 Gr.60	1,0425	A240 Gr.321	1,4541
18	Typenschild	A240 Gr.304	1,4301	A240 Gr.304	1,4301
19	Sicherungsschraube	A193 Gr.B8	A4-70	A193 Gr.B8	A4-70
20	Federring	A4/ASTM 316			
21	Deckelschrauben	A193 Gr.B8	A4-70	A193 Gr.B8	A4-70
22	Scheibenlager	A582 Gr. 303 beschichtet	1,4305 beschichtet	A582 Gr. 303 beschichtet	1,4305 beschichtet
23	Unterer Teile der Welle	A564 Gr. 630 (17-4 PH)	1,4542	A564 Gr. 630 (17-4 PH)	1,4542
24	Stiftschraube	A193 Gr.B8	A4-70	A193 Gr.B8	A4-70
25	Stopfbuchsmutter	A194 Gr.8	A4-70	A194 Gr.8	A4-70
26	Kerbnagel	A29,Gr1012 verzinkt	A4-70	A29,Gr1012 verzinkt	A4-70
27	Oberer Distanzring	A582 Gr.304	1,4305	A582 Gr.304	1,4305
28	Unterer Distanzring	A582 Gr.304	1,4305	A582 Gr.304	1,4305
30	C-Ring	Inconel 718	Inconel 718	Inconel 718	Inconel 718
31	Antriebssplint	A194 Gr.2	1,1191	A194 Gr.2	1,1191
32	Sicherungsring	1.4310/1.4122/ ASTM 301			
34	Zylinderstift	SS316	1,4401	SS316	1,4401
35	Stiftschraube	A193 Gr.B8	A4-70	A193 Gr.B8	A4-70

\* höhere Temperaturen auf Anfrage

# Maße und Gewichte Class 150

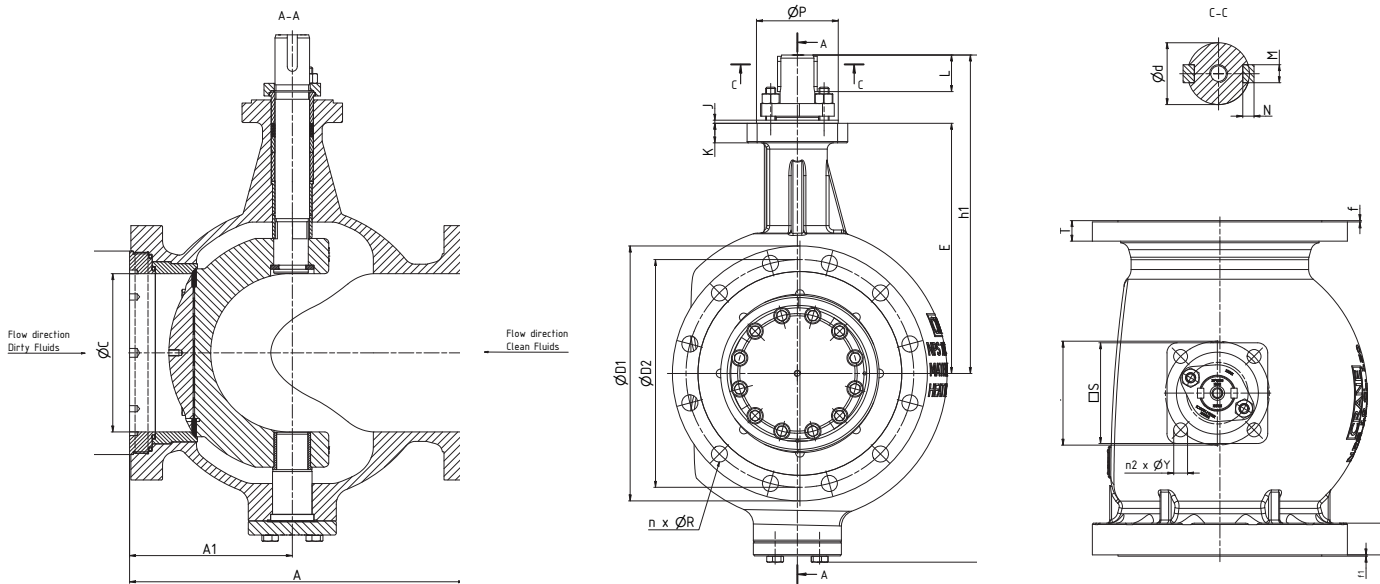

DN	NPS	Maße (Zoll)														
		A	$\varnothing C$	H	h1	E	$\varnothing D1$	$\varnothing D2$	n	$\varnothing R$	$\varnothing B$	T	f	T1	f1	A1
150	6"	16	5,9	24	16	12	11	10	8	0,87	8	1,0	0,08	1,5	0,08	6,4
200	8"	18	7,9	26	17	13	14	12	8	0,88	11	1,1	0,08	1,7	0,08	8,4
250	10"	21	9,9	32	20	16	16	14	12	1,00	13	1,2	0,08	2,0	0,08	10,2
300	12"	24	12	37	23	17	19	17	12	1,00	15	1,3	0,08	2,1	0,08	12,0
350	14"	27	13	42	26	20	21	19	12	1,12	16	1,4	0,08	2,3	0,08	13,1
400	16"	30	15	44	27	21	23	21	16	1,13	19	1,5	0,08	2,4	0,08	13,8
450	18"	34	17	48	29	22	25	23	16	1,26	21	1,6	0,08	2,4	0,08	15,7
500	20"	36	19	52	31	24	28	25	20	1,26	23	1,7	0,08	2,5	0,08	18,4
600	24"	42	23	64	39	30	32	30	20	1,38	27	1,9	0,08	2,9	0,08	20,7
700	28"	Größen 28"-36"/ DN700-900 auf Anfrage														
750	30"															
800	32"															
900	36"															

DN	NPS	Maße (Zoll)											
		ISO 5211	S (Vierkant)	$\varnothing P$	$\varnothing F$	n2	$\varnothing Y$	K	J	$\varnothing d$	L	M	N
150	6"	F16	6,7	5,1	6,5	4	0,9	1,4	0,2	1,8	2,0	0,6	0,4
200	8"	F16	6,7	5,1	6,5	4	0,9	1,4	0,2	1,8	2,0	0,6	0,4
250	10"	F16	6,3	5,1	6,5	4	0,9	1,2	0,2	2,2	2,3	0,6	0,4
300	12"	F25	11	8	10	8	0,7	1,3	0,2	2,6	2,8	0,7	0,4
350	14"	F25	11	8	10	8	0,7	1,3	0,2	3,0	2,8	0,8	0,5
400	16"	F25	11	8	10	8	0,7	1,3	0,2	3,0	3,1	0,8	0,5
450	18"	F30	13	9	12	8	0,8	1,5	0,2	3,5	4,1	1,0	0,5
500	20"	F30	13	9	12	8	0,8	1,5	0,2	3,5	4,1	1,0	0,5
600	24"	F35	16	10	14	8	1,3	1,9	0,2	4,3	6,3	1,1	0,6
700	28"	Größen 28"-36"/ DN700-900 auf Anfrage											
750	30"												
800	32"												
900	36"												

## Maße und Gewichte Class 150

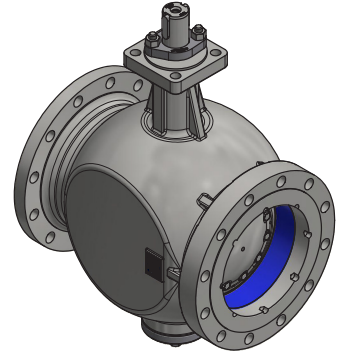
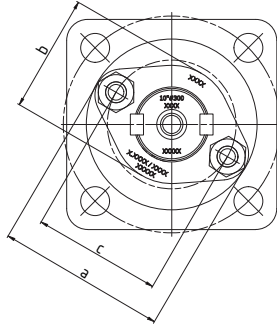
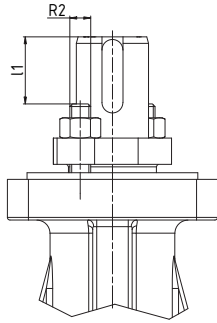

DN	NPS	Maße (Zoll)					Gewicht (lb)
		a	b	c	l1	R2	
150	6"	5,1	3,5	4,0	1,7	5/8-11 UNC	191
200	8"	5,1	3,5	4,0	1,8	5/8-11 UNC	330
250	10"	5,1	3,5	3,9	2,0	5/8-11 UNC	506
300	12"	6,7	4,7	5,1	2,2	3/4-10 UNC	847
350	14"	7,8	5,5	5,9	2,2	1-8 UNC	1136
400	16"	7,8	5,5	5,9	2,2	1-8 UNC	1401
450	18"	8,9	6,7	6,9	3,7	1-8 UNC	1857
500	20"	8,9	6,7	6,9	3,7	1-8 UNC	2309
600	24"	10,2	-	8,0	5,3	1-8 UNC	3931
700	28"	Größen 28"-36" / DN700-900 auf Anfrage					
750	30"						
800	32"						
900	36"						

# Maße und Gewichte Class 150

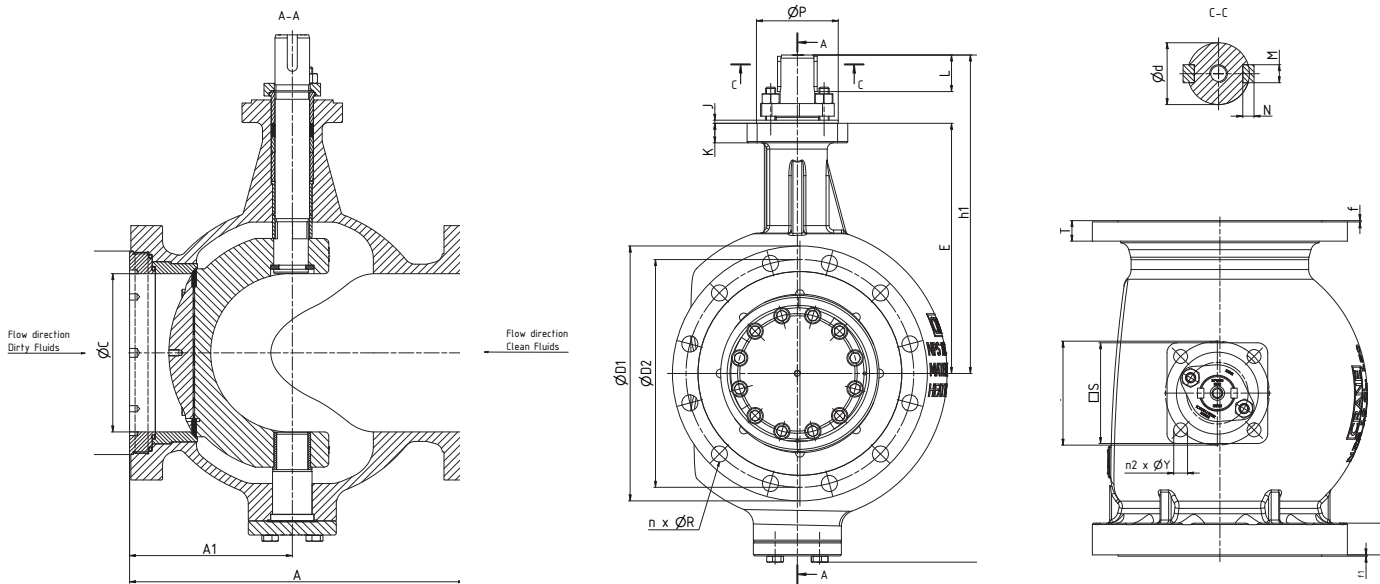

DN	NPS	Maße (mm)														
		A	Ø C	H	h1	E	Ø D1	Ø D2	n	Ø R	Ø B	T	f	T1	f1	A1
150	6"	394	150	597	395	299	280	241	8	22	216	26	2	39	2	163
200	8"	457	201	663	424	327	345	299	8	22	270	29	2	44	2	213
250	10"	533	252	806	506	398	405	362	12	25	324	31	2	51	2	259
300	12"	610	305	931	572	435	485	432	12	25	381	32	2	52	2	306
350	14"	686	334	1059	659	506	535	476	12	29	413	35	2	58	2	333
400	16"	762	378	1113	680	527	595	540	16	29	470	37	2	61	2	352
450	18"	864	436	1223	740	567	635	578	16	32	533	40	2	61	2	400
500	20"	914	487	1333	800	607	700	635	20	32	584	43	2	63	2	468
600	24"	1067	589	1621	995	774	815	749	20	35	692	48	2	74	2	527
700	28"	Größen 28"-36"/ DN700-900 auf Anfrage														
750	30"															
800	32"															
900	36"															

DN	NPS	Maße (mm)											
		ISO 5211	S (Vierkant)	Ø P	Ø F	n2	Ø Y	K	J	Ø d	L	M	N
150	6"	F16	170	130	165	4	22	35	5	45	52	14	9
200	8"	F16	170	130	165	4	22	35	5	45	52	14	9
250	10"	F16	160	130	165	4	22	31	5	55	58	16	10
300	12"	F25	270	200	254	8	17,5	34	5	65	72	18	11
350	14"	F25	280	200	254	8	17,5	33	5	75	72	20	12
400	16"	F25	280	200	254	8	17	33	5	75	80	20	12
450	18"	F30	330	230	298	8	21	38	5	90	103	25	12
500	20"	F30	330	230	298	8	21	38	5	90	103	25	12
600	24"	F35	410	260	356	8	33	49	5	110	160	28	16
700	28"	Größen 28"-36"/ DN700-900 auf Anfrage											
750	30"												
800	32"												
900	36"												



## Maße und Gewichte Class 150

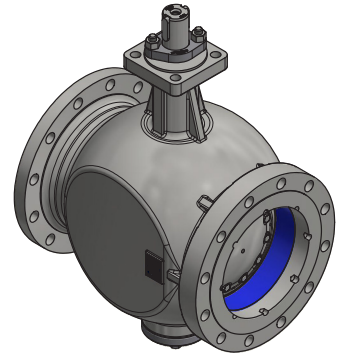
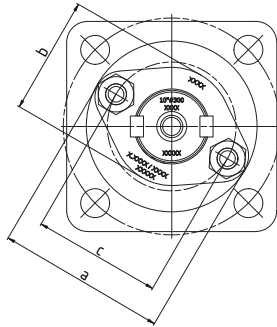
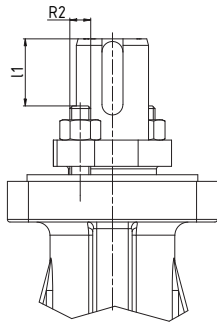

DN	NPS	Maße (mm)					Gewicht (kg)
		a	b	c	l1	R2	
150	6"	129	90	102	44	5/8-11 UNC	87
200	8"	129	90	102	45	5/8-11 UNC	150
250	10"	129	90	98	51	5/8-11 UNC	230
300	12"	170	120	130	56	3/4-10 UNC	384
350	14"	198	140	150	49	1-8 UNC	515
400	16"	198	140	150	54	1-8 UNC	636
450	18"	225	170	175	95	1-8 UNC	843
500	20"	225	170	175	95	1-8 UNC	1048
600	24"	258	-	204	136	1-1-8 UNC	1783
700	28"	Größen 28"-36" / DN700-900 auf Anfrage					
750	30"						
800	32"						
900	36"						

# Maße und Gewichte Class 300

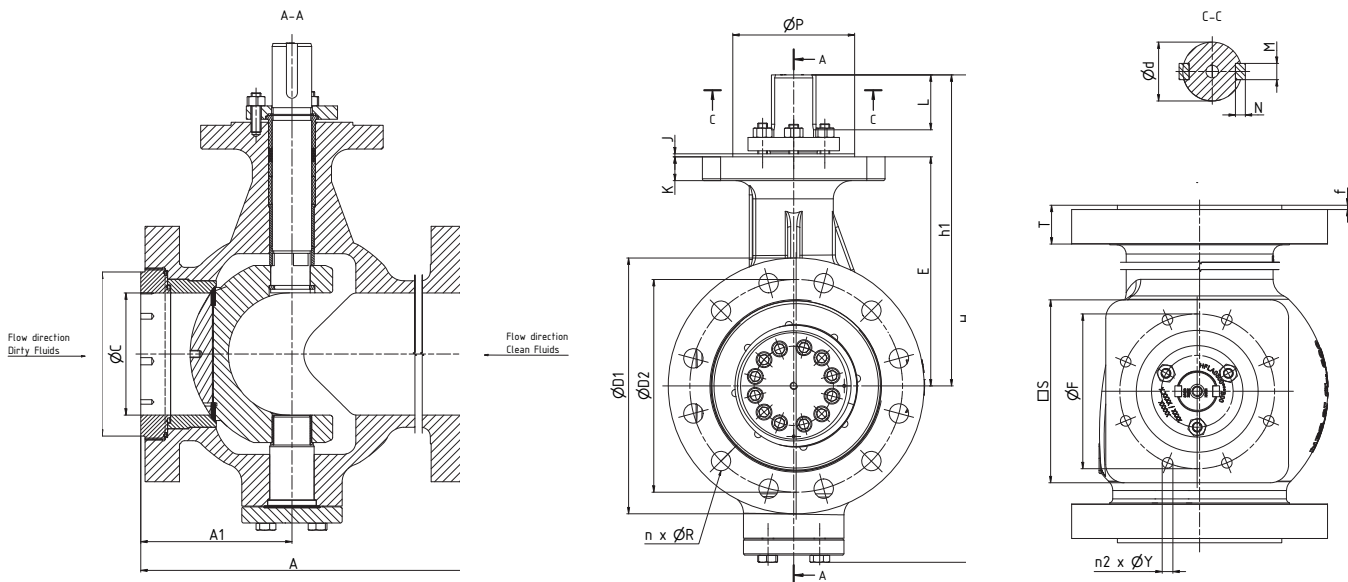

DN	NPS	Maße (Zoll)												
		A	Ø C	H	h1	E	Ø D1	Ø D2	n	Ø R	Ø B	T	f	A1
150	6"	16	6	23	15	12	13	11	12	0,9	9	1,5	0,08	6
200	8"	20	8	26	17	13	15	13	12	1,0	11	1,7	0,08	8
250	10"	22	10	32	20	16	18	15	16	1,1	13	1,9	0,08	10
300	12"	26	12	37	23	17	20	18	16	1,3	15	2,0	0,08	12
350	14"	30	13	42	26	20	23	20	20	1,3	16	2,1	0,08	13
400	16"	33	15	44	27	21	26	23	20	1,4	18	2,3	0,08	14
450	18"	36	17	51	31	25	28	25	24	1,4	21	2,4	0,08	16
500	20"	39	19	53	32	26	31	27	24	1,4	23	2,5	0,08	18
600	24"	45	23	57	34	25	36	32	24	1,7	27	2,8	0,08	21
700	28"	Größen 28"-36"/ DN700-900 auf Anfrage												
750	30"													
800	32"													
900	36"													

DN	NPS	Maße (Zoll)											
		ISO 5211	S (Vierkant)	Ø P	Ø F	n2	Ø Y	K	J	Ø d	L	M	N
150	6"	F16	6,7	5,1	6,5	4	0,9	1,4	0,2	1,8	2,0	0,6	0,4
200	8"	F16	6,3	5,1	6,5	4	0,9	1,4	0,2	1,8	2,0	0,6	0,4
250	10"	F16	6,3	5,1	6,5	4	0,9	1,2	0,2	2,2	2,3	0,6	0,4
300	12"	F25	10,6	7,9	10,0	8	0,7	1,3	0,2	2,6	2,8	0,7	0,4
350	14"	F25	11,0	7,9	10,0	8	0,7	1,3	0,2	2,95	2,8	0,8	0,5
400	16"	F25	11,0	7,9	10,0	8	0,7	1,3	0,2	3,0	3,1	0,8	0,5
450	18"	F30	12,6	9,1	11,7	8	0,8	1,5	0,2	3,5	3,7	1,0	0,5
500	20"	F30	13,0	10,2	11,7	8	0,9	1,5	0,2	3,5	3,7	1,0	0,5
600	24"	F35	16,3	10,2	14,0	8	1,2	1,7	0,2	4,3	6,3	1,1	0,6
700	28"	Größen 28"-36"/ DN700-900 auf Anfrage											
750	30"												
800	32"												
900	36"												

# Maße und Gewichte Class 300

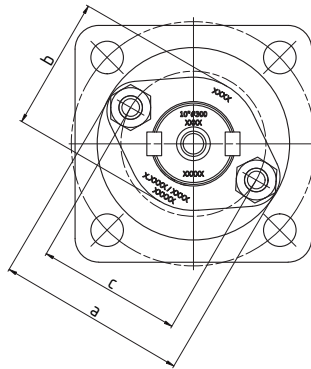
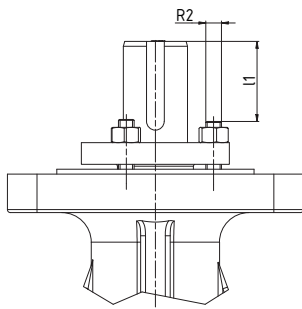

Größen 6"-20"

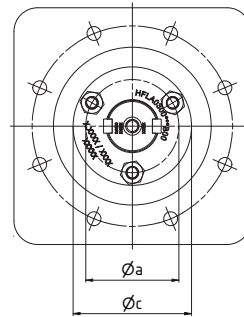

Größen 24"-36"

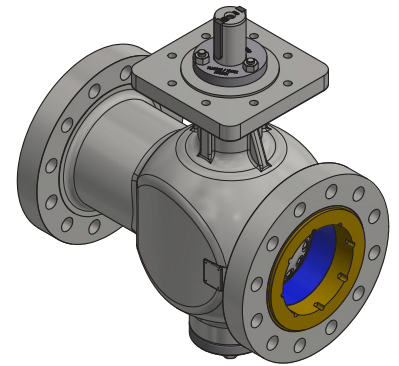

DN	NPS	Maße (Zoll)					Gewicht (lb)
		a / Ø a	b	c / Ø c	l1	R2	
150	6"	5,1	3,5	4,0	1,7	5/8-11 UNC	230
200	8"	5,1	3,5	4,0	1,7	5/8-11 UNC	398
250	10"	5,1	3,5	3,9	2,0	5/8-11 UNC	615
300	12"	6,7	4,7	5,1	2,2	3/4-10 UNC	986
350	14"	7,8	5,5	5,9	1,9	1-8 UNC	1368
400	16"	7,8	5,5	5,9	2,1	1-8 UNC	1770
450	18"	8,9	6,7	6,9	2,0	1-8 UNC	2484
500	20"	8,9	6,7	6,9	2,0	1-8 UNC	3142
600	24"	8,3	-	6,4	6,0	1-8 UNC	6226
700	28"	Größen 28"-36" / DN700-900 auf Anfrage					
750	30"						
800	32"						
900	36"						

# Maße und Gewichte Class 300

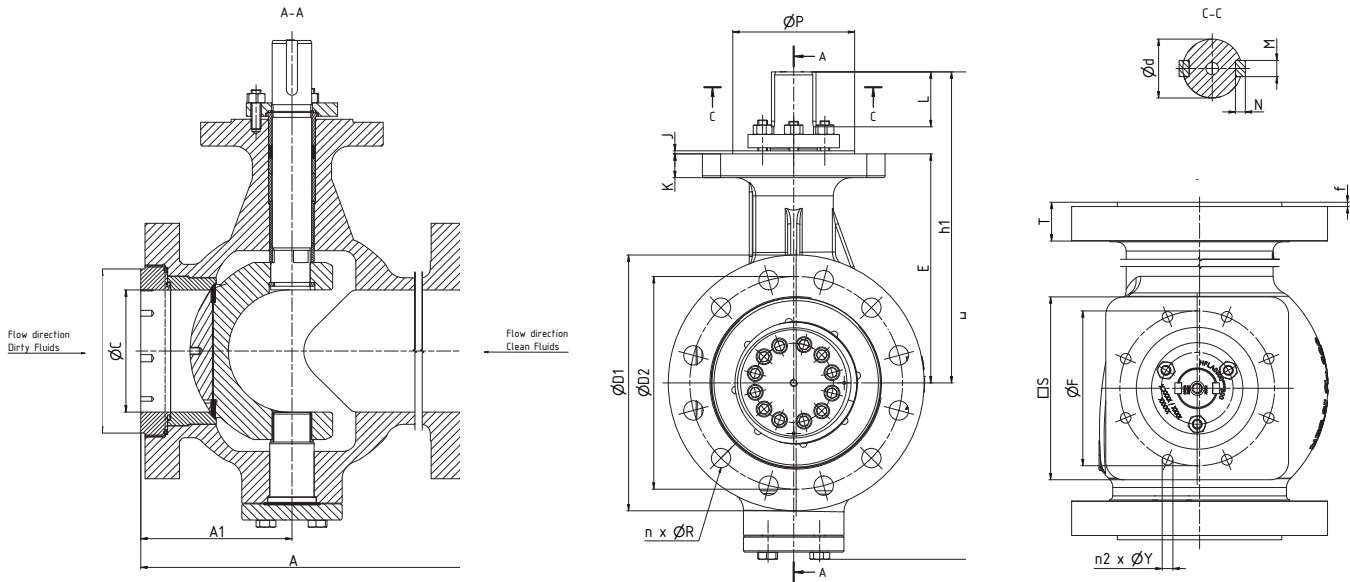

DN	NPS	Maße (mm)												
		A	$\varnothing C$	H	h1	E	$\varnothing D1$	$\varnothing D2$	n	$\varnothing R$	$\varnothing B$	T	f	A1
150	6"	403	152	596	393	299	320	270	12	22	216	37	2	163
200	8"	502	203	662	423	329	380	330	12	25	270	43	2	203
250	10"	568	254	807	507	399	445	387	16	29	324	48	2	259
300	12"	648	305	931	572	435	520	451	16	32	381	51	2	316
350	14"	762	336	1059	659	506	585	514	20	32	413	54	2	323
400	16"	838	387	1127	687	534	650	572	20	35	470	58	2	364
450	18"	914	436	1290	777	625	710	629	24	35	533	61	2	414
500	20"	991	487	1356	814	662	775	686	24	35	584	64	2	451
600	24"	1143	589	1443	860	647	915	813	24	42	692	72	2	526
700	28"	Größen 28"-36"/ DN700-900 auf Anfrage												
750	30"													
800	32"													
900	36"													

DN	NPS	Maße (mm)											
		ISO 5211	S (Vierkant)	$\varnothing P$	$\varnothing F$	n2	$\varnothing Y$	K	J	$\varnothing d$	L	M	N
150	6"	F16	170	130	165	4	22	35	5	45	52	14	9
200	8"	F16	160	130	165	4	22	35	5	45	52	14	9
250	10"	F16	160	130	165	4	22	31	5	55	58	16	10
300	12"	F25	270	200	254	8	17,5	34	5	65	72	18	11
350	14"	F25	280	200	254	8	17,5	33	5	75	72	20	12
400	16"	F25	280	200	254	8	17	33	5	75	80	20	12
450	18"	F30	320	230	298	8	21	38	5	90	94	25	12
500	20"	F30	330	260	298	8	22	38	5	90	94	25	12
600	24"	F35	415	260	356	8	31	44	5	110	160	28	16
700	28"	Größen 28"-36"/ DN700-900 auf Anfrage											
750	30"												
800	32"												
900	36"												

# Maße und Gewichte Class 300

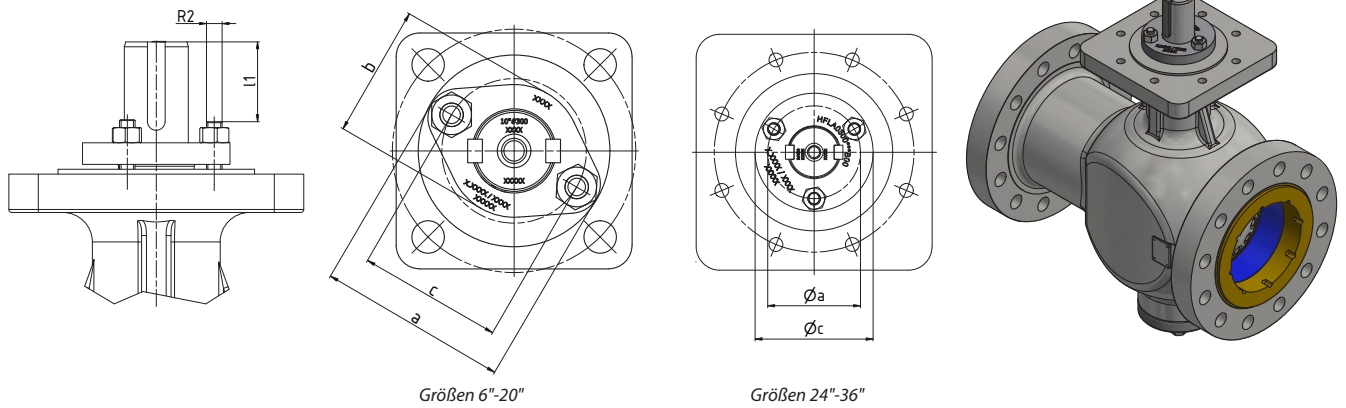

DN	NPS	Maße (mm)					Gewicht (kg)	
		a / Ø a	b	c / Ø c	l1	R2		
150	6"	129	90	102	42	5/8-11 UNC	105	
200	8"	129	90	102	44	5/8-11 UNC	181	
250	10"	129	90	98	52	5/8-11 UNC	279	
300	12"	170	120	130	56	3/4-10 UNC	447	
350	14"	198	140	150	49	1-8 UNC	621	
400	16"	198	140	150	52	1-8 UNC	803	
450	18"	225	170	175	52	1-8 UNC	1127	
500	20"	225	170	175	52	1-8 UNC	1426	
600	24"	210	-	162	152	1-8 UNC	2825	
700	28"	Größen 28"-36" / DN700-900 auf Anfrage						
750	30"							
800	32"							
900	36"							

# Maße und Gewichte Class 600

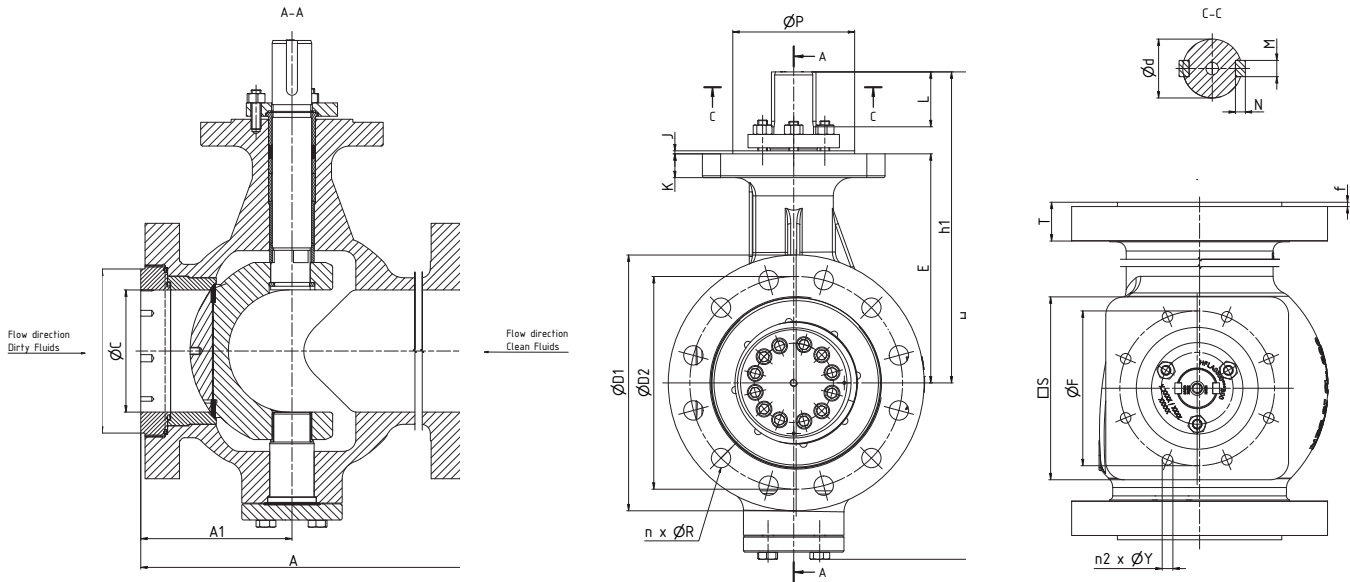

DN	NPS	Maße (Zoll)												
		A	Ø C	H	h1	E	Ø D1	Ø D2	n	Ø R	Ø B	T	f	A1
150	6"	22	6	25	16	12	14	11	12	1,1	8,5	2,0	0,28	8
200	8"	26	8	31	20	15	17	14	12	1,3	10,6	2,2	0,28	10
250	10"	31	10	37	24	18	20	17	16	1,4	13	2,6	0,28	12
300	12"	33	12	41	26	20	22	19	20	1,4	15	2,7	0,28	13
350	14"	35	13	45	27	20	24	21	20	1,5	16	2,8	0,28	13
400	16"	39	15	49	31	23	27	24	20	1,6	19	3,1	0,28	15
450	18"	43	17	55	35	26	29	26	20	1,8	21	3,3	0,28	18
500	20"	47	19	60	37	28	32	29	24	1,7	23	3,5	0,28	19
600	24"	55	22	69	42	30	37	33	24	2,0	27	4,1	0,28	21
700	28"	Größen 28"-36"/ DN700-900 auf Anfrage												
750	30"													
800	32"													
900	36"													

DN	NPS	Maße (Zoll)											
		ISO 5211	S (Vierkant)	Ø P	Ø F	n2	Ø Y	K	J	Ø d	L	M	N
150	6"	F16	6	5	6	4	0,9	0,8	0,20	1,8	2,5	0,6	0,4
200	8"	F25	12	8	10	8	0,7	1,5	0,20	2,6	3,5	0,7	0,4
250	10"	F30	14	9	12	8	0,9	1,6	0,20	2,8	3,9	0,8	0,5
300	12"	F30	14	9	12	8	0,9	1,6	0,20	3,1	3,9	0,9	0,6
350	14"	F30	14	9	12	8	0,9	1,6	0,20	3,5	4,9	1,0	0,6
400	16"	F35	16	10	14	8	1,3	2,1	0,20	3,9	5,5	1,1	0,6
450	18"	F40	16	10	14	8	1,3	2,1	0,20	4,3	6,3	1,1	0,6
500	20"	F48	19	12	16	8	1,5	2,4	0,39	4,7	7,1	1,3	0,7
600	24"	F48	22	15	19	12	1,5	2,8	0,39	5,5	8,7	1,4	0,8
700	28"	Größen 28"-36"/ DN700-900 auf Anfrage											
750	30"												
800	32"												
900	36"												

# Maße und Gewichte Class 600

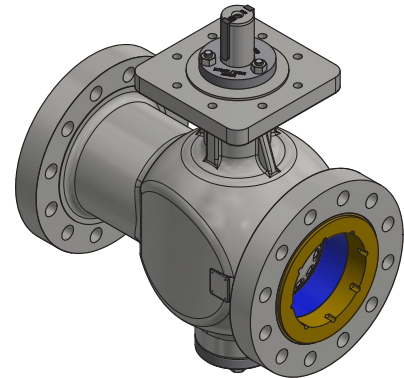
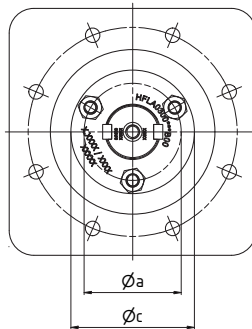
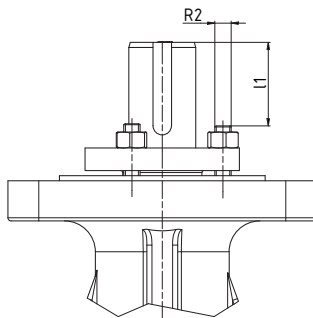

DN	NPS	Maße (Zoll)				Gewicht (lb)
		Ø a	Ø c	l1	R2	
150	6"	4,8	3,7	2,6	9/16-12 UNC	366
200	8"	5,9	4,6	3,2	5/8-11 UNC	674
250	10"	6,8	5,3	3,7	3/4-10 UNC	1106
300	12"	8,3	6,4	3,5	1-8 UNC	1496
350	14"	8,7	6,8	4,2	1-8 UNC	1720
400	16"	9,1	7,2	4,6	1-8 UNC	2617
450	18"	10	8,0	5,3	1-8 UNC	3640
500	20"	11	8,7	7,0	1 1/2-8 UNC	4788
600	24"	13	10,4	9,0	1 1/2-8 UNC	7022
700	28"	Größen 28"-36" / DN700-900 auf Anfrage				
750	30"					
800	32"					
900	36"					

# Maße und Gewichte Class 600

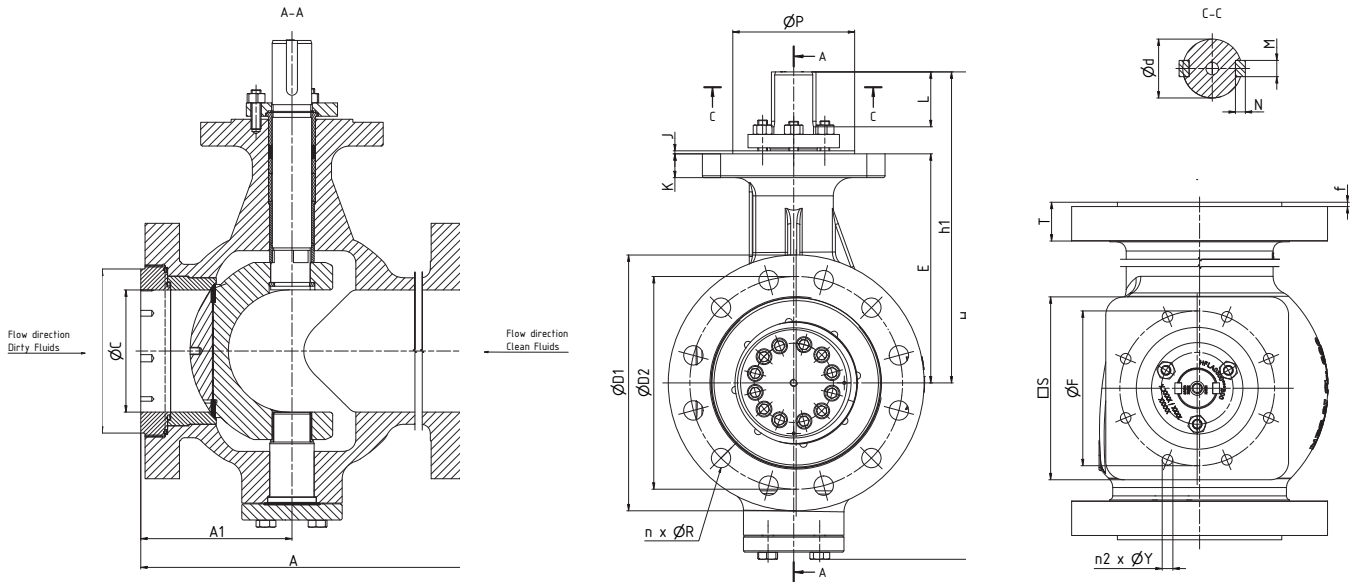

DN	NPS	Maße (mm)												
		A	Ø C	H	h1	E	Ø D1	Ø D2	n	Ø R	Ø B	T	f	A1
150	6"	559	152	634	416	308	355	292	12	28	216	50	7	211
200	8"	660	201	800	511	376	420	349	12	32	270	56	7	249
250	10"	787	252	949	608	450	510	432	16	35	324	66	7	293
300	12"	838	303	1051	671	506	560	489	20	35	381	69	7	328
350	14"	889	334	1136	698	510	605	527	20	38	413	71	7	327
400	16"	991	385	1249	775	578	685	603	20	41	470	78	7	387
450	18"	1092	436	1409	880	664	745	654	20	45	533	85	7	451
500	20"	1194	487	1519	940	704	815	724	24	44	584	89	7	490
600	24"	1397	589	1750	1076	755	940	838	24	51	692	105	7	526
700	28"	Größen 28"-36"/ DN700-900 auf Anfrage												
750	30"													
800	32"													
900	36"													

DN	NPS	Maße (mm)											
		ISO 5211	S (Vierkant)	Ø P	Ø F	n2	Ø Y	K	J	Ø d	L	M	N
150	6"	F16	160	130	165	4	22	20	5	45	63	14	9
200	8"	F25	300	200	254	8	17,5	39	5	65	90	18	11
250	10"	F30	350	230	298	8	22	40	5	70	100	20	12
300	12"	F30	350	230	298	8	22	40	5	80	100	22	14
350	14"	F30	350	230	298	8	22	40	5	90	125	25	14
400	16"	F35	410	260	356	8	33	53	5	100	140	28	16
450	18"	F40	415	260	356	8	33	53	5	110	160	28	16
500	20"	F40	475	300	406	8	39	60	10	120	180	32	18
600	24"	F48	560	370	483	12	39	72	10	140	220	36	20
700	28"	Größen 28"-36"/ DN700-900 auf Anfrage											
750	30"												
800	32"												
900	36"												



# Maße und Gewichte Class 600

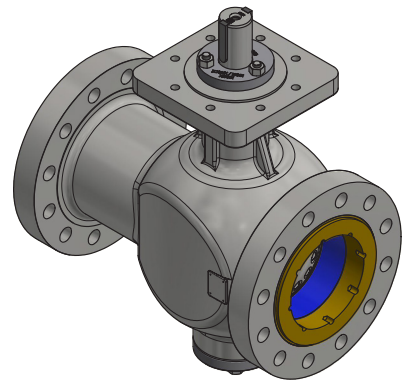
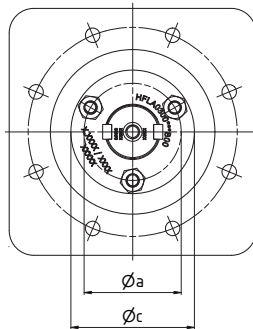
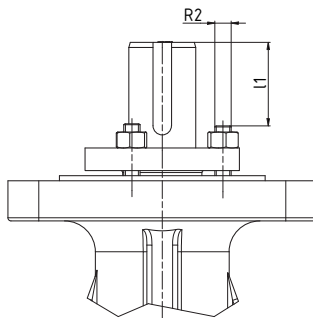

DN	NPS	Maße (mm)				Gewicht (kg)
		Ø a	Ø c	l1	R2	
150	6"	122	94	63,4	9/16-12 UNC	166
200	8"	150	118	79	5/8-11 UNC	306
250	10"	172	134	91	3/4-10 UNC	502
300	12"	210	162	86	1-8 UNC	679
350	14"	220	172	102	1-8 UNC	781
400	16"	230	182	113	1-8 UNC	1187
450	18"	258	204	130	1-8 UNC	1652
500	20"	280	222	172	1 1/2-8 UNC	2173
600	24"	334	264	220	1 1/2-8 UNC	3186
700	28"	Größen 28"-36" / DN700-900 auf Anfrage				
750	30"					
800	32"					
900	36"					

# Druck-/Temperaturbereich

Temperatur	Maximaler Betriebsdruck ASME Class 150	Max. Betriebsdruck ASME Class 300	Max. Betriebsdruck ASME Class 600
	ASTM A216 Gr. WCB*		
°F	psi		
-20	285	740	1480
100	285	740	1480
200	260	680	1360
300	230	655	1310
400	200	635	1265
500	170	605	1205
600	140	570	1135
650	125	550	1100
700	110	530	1060
750**	95	505	1015
800**	80	410	825

\*nach ASME B16.34 – Werkstoffgruppe 1.1  
 \*\* Werkstoffberatung auf Anfrage

Temperatur	Maximaler Betriebsdruck ASME Class 150	Max. Betriebsdruck ASME Class 300	Max. Betriebsdruck ASME Class 600
	ASTM A351 Gr. CF8M*		
°F	psi		
-76	275	720	1440
-20	275	720	1440
100	275	720	1440
200	235	620	1240
300	215	560	1120
400	195	515	1025
500	170	480	955
600	140	450	900
650	125	440	885
700**	110	435	870
750**	95	425	855
800**	80	420	845
850**	65	420	835
900**	50	415	830
950**	35	385	775
1000**	20	365	725

\*nach ASME B16.34 – Werkstoffgruppe 2.2  
 \*\* Werkstoffberatung auf Anfrage

**Druck und Temperatur**  
ASTM A216 Gr. WCB

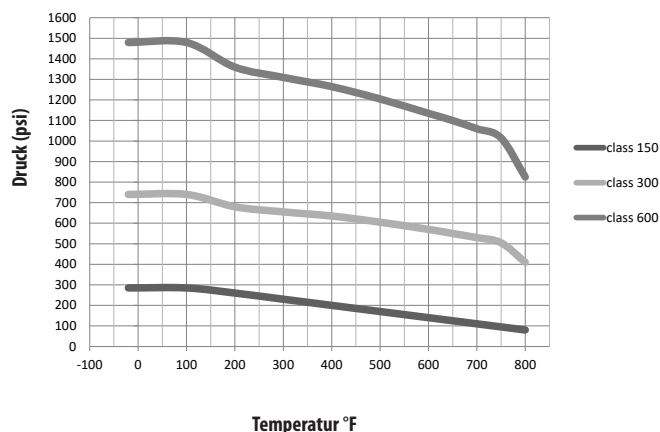

**Druck und Temperatur**  
ASTM A351 Gr. CF8M

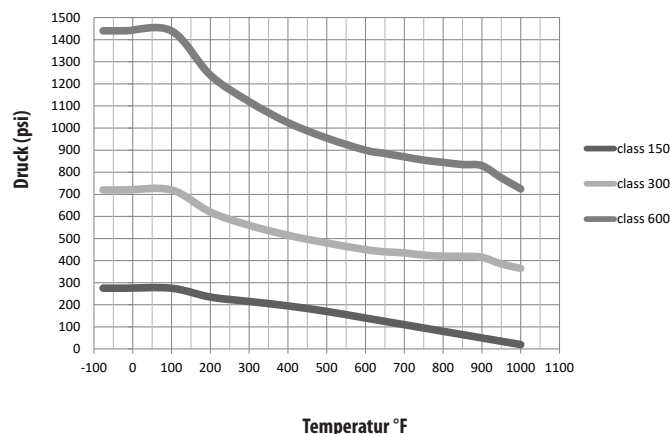

# Druck-/Temperaturbereich

Temperatur	Maximaler Betriebsdruck ASME Class 150	Max. Betriebsdruck ASME Class 300	Max. Betriebsdruck ASME Class 600
	ASTM A216 Gr. WCB*		
°C	bar		
-29	19,6	51,1	102,1
50	19,2	50,1	100,2
100	17,7	46,6	93,2
150	15,8	45,1	90,2
200	13,8	43,8	87,6
250	12,1	41,9	83,9
300	10,2	39,8	79,6
350	8,4	37,6	75,1
400**	6,5	34,7	69,4
425**	5,5	28,8	57,5

\*nach ASME B16.34 – Werkstoffgruppe 1.1  
 \*\* Werkstoffberatung auf Anfrage

Temperatur	Maximaler Betriebsdruck ASME Class 150	Max. Betriebsdruck ASME Class 300	Max. Betriebsdruck ASME Class 600
	ASTM A351 Gr. CF8M*		
°C	bar		
-60	19,0	49,6	99,3
-29	19,0	49,6	99,3
50	18,4	48,1	96,2
100	16,2	42,2	84,4
150	14,8	38,5	77,0
200	13,7	35,7	71,3
250	12,1	33,4	66,8
300	10,2	31,6	63,2
350	8,4	30,3	60,7
400**	6,5	29,4	58,9
450**	4,6	28,8	57,7
500**	2,8	28,2	56,5
538**	1,4	25,2	50,0

\*nach ASME B16.34 – Werkstoffgruppe 2.2  
 \*\* Werkstoffberatung auf Anfrage

**Druck und Temperatur  
 ASTM A216 Gr. WCB**

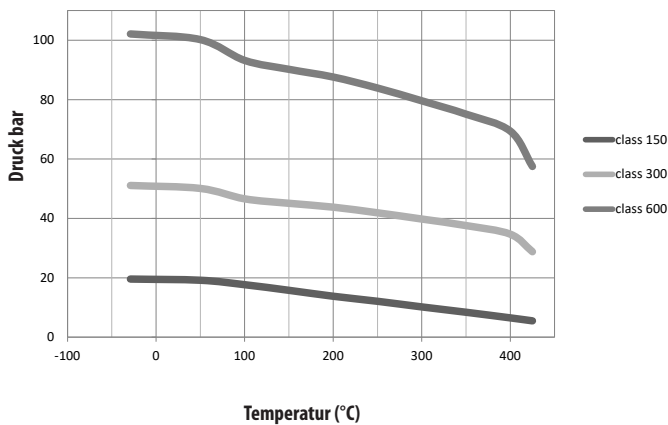

**Druck und Temperatur  
 ASTM A351 Gr. CF8M**

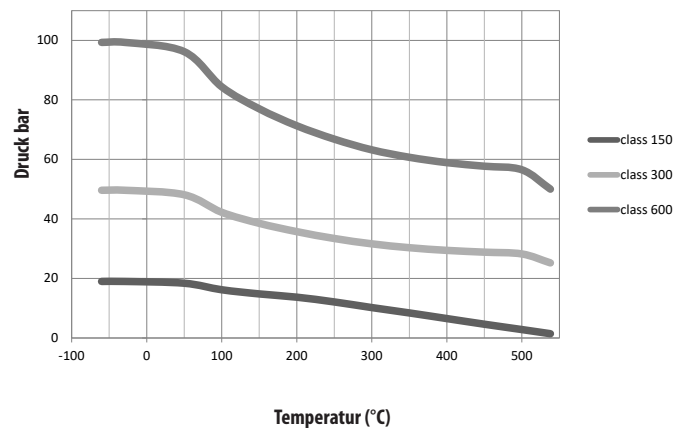

# MAST Class 150

## Maximal zulässiges Antriebsmoment (MAST), Class 150

		MAST [in-Lb]							
		Schaltwellenwerkstoff							
Schlüssel		A	B	C	D	E	F	H	M
DN	NPS	ASTM A564 Gr. 630 (17-4PH)	ASTM A276 Gr. 431	ASTM A182 Gr. F55	ASTM A182 Gr. F51	ASTM A453 Gr. 660	ASTM A479 Gr. XM-19 (Nitronic 50)	ASTM UNS N06022 (Hastelloy C22)	ASTM B865 Monel K500
		1.4542	1.4057	1.4501	1.4462	1.4980	1.3964	2.4602	2.4375
150	6"	62592	51803	45758	38846	51803	31508	26765	59565
200	8"	62592	51803	45758	38846	51803	31508	26765	59565
250	10"	119511	98907	87365	74178	98907	60167	51104	113740
300	12"	198123	163968	144833	122972	163968	99747	84719	188564
350	14"	248023	205257	181315	153940	205257	124866	106049	236048
400	16"	312474	258600	228428	193945	258600	157312	133610	297384
450	18"	540309	447155	394989	335362	447155	272017	231030	514226
500	20"	540309	447155	394989	335362	447155	272017	231030	514226
600	24"	1051428	870148	768630	652615	870148	529343	449580	1000669
700	28"	Größen 28"-36" / DN 700-900 auf Anfrage							
750	30"								
800	32"								
850	34"								
900	36"								

		MAST [Nm]							
		Schaltwellenwerkstoff							
Schlüssel		A	B	C	D	E	F	H	M
DN	NPS	ASTM A564 Gr. 630 (17-4PH)	ASTM A276 Gr. 431	ASTM A182 Gr. F55	ASTM A182 Gr. F51	ASTM A453 Gr. 660	ASTM A479 Gr. XM-19 (Nitronic 50)	ASTM UNS N06022 (Hastelloy C22)	ASTM B865 Monel K500
		1.4542	1.4057	1.4501	1.4462	1.4980	1.3964	2.4602	2.4375
150	6"	7072	5853	5170	4389	5853	3560	3024	6730
200	8"	7072	5853	5170	4389	5853	3560	3024	6730
250	10"	13503	11175	9871	8381	11175	6798	5774	12851
300	12"	22385	18526	16364	13894	18526	11270	9572	21305
350	14"	28023	23191	20486	17393	23191	14108	11982	26670
400	16"	35305	29218	25809	21913	29218	17774	15096	33600
450	18"	61047	50522	44628	37891	50522	30734	26103	58100
500	20"	61047	50522	44628	37891	50522	30734	26103	58100
600	24"	118796	98314	86844	73736	98314	59808	50796	113061
700	28"	Größen 28"-36" / DN 700-900 auf Anfrage							
750	30"								
800	32"								
850	34"								
900	36"								

# MAST Class 300

## Maximal zulässiges Antriebsmoment (MAST), Class 300

		MAST [in-Lb]							
		Schaltwellenwerkstoff							
Schlüssel		A	B	C	D	E	F	H	M
DN	NPS	ASTM A564 Gr. 630 (17-4PH)	ASTM A276 Gr. 431	ASTM A182 Gr. F55	ASTM A182 Gr. F51	ASTM A453 Gr. 660	ASTM A479 Gr. XM-19 (Nitronic 50)	ASTM UNS N06022 (Hastelloy C22)	ASTM B865 Monel K500
		1.4542	1.4057	1.4501	1.4462	1.4980	1.3964	2.4602	2.4375
150	6"	62591	51800	45756	38850	51800	31511	26763	59569
200	8"	62591	51800	45756	38850	51800	31511	26763	59569
250	10"	119510	98905	87366	74178	98905	60167	51101	113740
300	12"	198126	163967	144837	122975	163967	99746	84716	188561
350	14"	248020	205258	181311	153944	205258	124865	106050	236047
400	16"	312471	258596	228427	193947	258596	157313	133608	297386
450	18"	540309	447152	394985	335364	447152	272018	231029	514225
500	20"	540309	447152	394985	335364	447152	272018	231029	514225
600	24"	1051432	870151	768633	652613	870151	529342	449578	1000673
700	28"	Größen 28"-36" / DN 700-900 auf Anfrage							
750	30"								
800	32"								
900	36"								

		MAST [Nm]							
		Schaltwellenwerkstoff							
Schlüssel		A	B	C	D	E	F	H	M
DN	NPS	ASTM A564 Gr. 630 (17-4PH)	ASTM A276 Gr. 431	ASTM A182 Gr. F55	ASTM A182 Gr. F51	ASTM A453 Gr. 660	ASTM A479 Gr. XM-19 (Nitronic 50)	ASTM UNS N06022 (Hastelloy C22)	ASTM B865 Monel K500
		1.4542	1.4057	1.4501	1.4462	1.4980	1.3964	2.4602	2.4375
150	6"	7072	5853	5170	4389	5853	3560	3024	6730
200	8"	7072	5853	5170	4389	5853	3560	3024	6730
250	10"	13503	11175	9871	8381	11175	6798	5774	12851
300	12"	22385	18526	16364	13894	18526	11270	9572	21305
350	14"	28023	23191	20486	17393	23191	14108	11982	26670
400	16"	35305	29218	25809	21913	29218	17774	15096	33600
450	18"	61047	50522	44628	37891	50522	30734	26103	58100
500	20"	61047	50522	44628	37891	50522	30734	26103	58100
600	24"	118796	98314	86844	73736	98314	59808	50796	113061
700	28"	Größen 28"-36" / DN 700-900 auf Anfrage							
750	30"								
800	32"								
900	36"								

# MAST Class 600

## Maximal zulässiges Antriebsmoment (MAST), Class 600

		MAST [in-Lb]							
		Schaltwellenwerkstoff							
Schlüssel		A	B	C	D	E	F	H	M
DN	NPS	ASTM A564 Gr. 630 (17-4PH)	ASTM A276 Gr. 431	ASTM A182 Gr. F55	ASTM A182 Gr. F51	ASTM A453 Gr. 660	ASTM A479 Gr. XM-19 (Nitronic 50)	ASTM UNS N06022 (Hastelloy C22)	ASTM B865 Monel K500
		1.4542	1.4057	1.4501	1.4462	1.4980	1.3964	2.4602	2.4375
150	6"	62591	51800	45756	38850	51800	31511	26763	59569
200	8"	198126	163967	144837	122975	163967	99746	84716	188561
250	10"	248020	205258	181311	153944	205258	124865	106050	236047
300	12"	363190	225428	265504	225428	300571	182847	155295	345657
350	14"	540309	447152	394985	335364	447152	272018	231029	514225
400	16"	741180	613390	541828	460043	613390	373146	316918	705399
450	18"	986073	816060	720853	612045	816060	496437	421631	938469
500	20"	1319974	1092392	964946	819294	1092392	664538	564403	1256251
600	24"	2145000	1775172	1568069	1331379	1775172	1079897	917172	2041448
700	28"	Größen 28"-36" / DN 700-900 auf Anfrage							
750	30"								
800	32"								
850	34"								
900	36"								

		MAST [Nm]							
		Schaltwellenwerkstoff							
Schlüssel		A	B	C	D	E	F	H	M
DN	NPS	ASTM A564 Gr. 630 (17-4PH)	ASTM A276 Gr. 431	ASTM A182 Gr. F55	ASTM A182 Gr. F51	ASTM A453 Gr. 660	ASTM A479 Gr. XM-19 (Nitronic 50)	ASTM UNS N06022 (Hastelloy C22)	ASTM B865 Monel K500
		1.4542	1.4057	1.4501	1.4462	1.4980	1.3964	2.4602	2.4375
150	6"	7072	5853	5170	4389	5853	3560	3024	6730
200	8"	22385	18526	16364	13894	18526	11270	9572	21305
250	10"	28023	23191	20486	17393	23191	14108	11982	26670
300	12"	41035	25470	29998	25470	33960	20659	17546	39054
350	14"	61047	50522	44628	37891	50522	30734	26103	58100
400	16"	83743	69304	61219	51978	69304	42160	35807	79700
450	18"	111412	92203	81446	69152	92203	56090	47638	106033
500	20"	149138	123424	109025	92568	123424	75083	63769	141938
600	24"	242354	200569	177169	150426	200569	122013	103627	230654
700	28"	Größen 28"-36" / DN 700-900 auf Anfrage							
750	30"								
800	32"								
850	34"								
900	36"								

# Kv-/Cv-Werte

## Kv-/Cv-Werte Class 150-300

DN	NPS	Öffnungswinkel	
		90°	
		Kv	Cv
150	6"	2276	2647
200	8"	4893	5689
250	10"	7565	8796
300	12"	11272	13107
350	14"	14766	17170
400	16"	19915	23157
450	18"	24894	28946
500	20"	31906	37100
600	24"	45798	53254
700	28"	Größen 28"-36" / DN 700-900 auf Anfrage	
750	30"		
800	32"		
900	36"		

## Kv-/Cv-Werte Class 300-300

DN	NPS	Öffnungswinkel	
		90°	
		Kv	Cv
150	6"	2176	2530
200	8"	4874	5667
250	10"	7495	8715
300	12"	11165	12982
350	14"	14310	16639
400	16"	19647	22845
450	18"	22882	26607
500	20"	30186	35100
600	24"	44899	52208
700	28"	Größen 28"-36" / DN 700-900 auf Anfrage	
750	30"		
800	32"		
900	36"		

## Kv-/Cv-Werte Class 600-300

DN	NPS	Öffnungswinkel	
		90°	
		Kv	Cv
150	6"	2219	2481
200	8"	4300	5000
250	10"	7093	8248
300	12"	9963	11585
350	14"	13198	15347
400	16"	18656	21693
450	18"	21586	25100
500	20"	27606	32100
600	24"	44309	51522
700	28"	Größen 28"-36" / DN 700-900 auf Anfrage	
750	30"		
800	32"		
900	36"		

Berechnung Cv-Werte 150 und 300 für Rohrklasse 40  
 Berechnung Cv-Wert 600 für Rohrklasse 80

# Flanschverschraubung

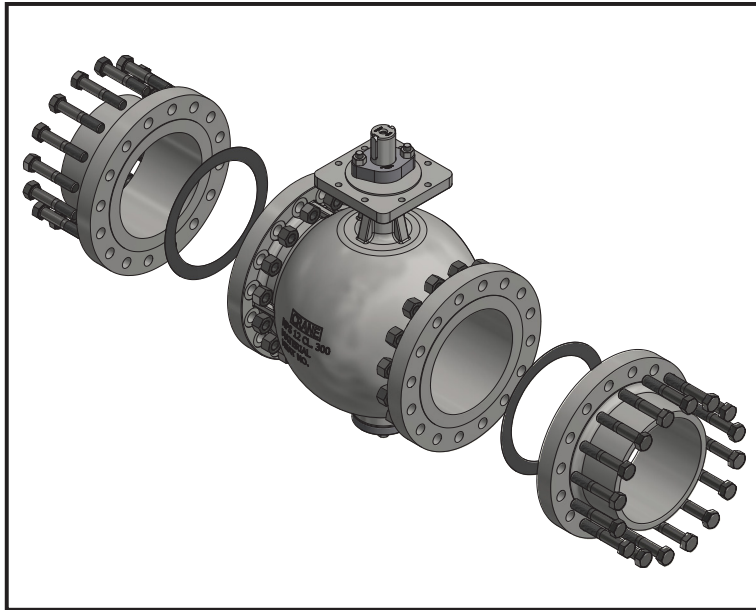

Allgemeines:  
 Anzahl der benötigten Schrauben und Muttern für die gesamte Armatur  
 Gegenflansch nach AMSE B16.5  
 Dicke der Flanschdichtung 2 mm  
 Schrauben nach ASME B18.2.1

## Class 150

DN	NPS	Gewinde	L (Spindelseite)	Anzahl Schrauben	L (Scheibenseite)	Anzahl Schrauben	Anzahl Muttern
150	6"	3/4-10 UNC	3 1/4"	8	4 1/4"	8	16
200	8"	3/4-10 UNC	3 1/2"	8	4 3/4"	8	16
250	10"	7/8-9 UNC	3 3/4"	12	5 1/4"	12	24
300	12"	7/8-9 UNC	4"	12	5 1/2"	12	24
350	14"	1-8 UNC	4 1/4"	12	6"	12	24
400	16"	1-8 UNC	4 1/4"	16	6 1/4"	16	32
450	18"	1 1/8-8 UN	4 3/4"	16	6 1/2"	16	32
500	20"	1 1/8-8 UN	5"	20	7"	20	40
600	24"	1 1/4-8 UN	5 1/2"	20	7 1/2"	20	40
<b>Flansch mit Dichtleiste nach ASME B16.47</b>							
700	28"	Größen 28"-36" / DN 700-900 auf Anfrage					
750	30"						
800	32"						
900	36"						



## Class 300

DN	NPS	Gewinde	L	Anzahl Schrauben	Anzahl Muttern
150	6"	3/4-10 UNC	4 1/4"	24	24
200	8"	7/8-9 UNC	4 3/4"	24	24
250	10"	1-8 UNC	5 1/4"	32	32
300	12"	1 1/8-8 UN	5 1/2"	32	32
350	14"	1 1/8-8 UN	6"	40	40
400	16"	1 1/4-8 UN	6 1/4"	40	40
450	18"	1 1/4-8 UN	6 1/2"	48	48
500	20"	1 1/4-8 UN	7"	48	48
600	24"	1 1/2-8 UN	7 1/2"	48	48
<b>Flansch mit Dichtleiste nach ASME B16.47</b>					
700	28"	Größen 28"-36" / DN 700-900 auf Anfrage			
750	30"				
800	32"				
900	36"				

## Class 600

DN	NPS	Gewinde	L	Anzahl Schrauben	Anzahl Muttern
150	6"	1-8 UNC	3 3/4"	24	24
200	8"	1 1/8-8 UN	4 1/4"	24	24
250	10"	1 1/4-8 UN	4 1/2"	32	32
300	12"	1 1/4-8 UN	4 3/4"	40	40
350	14"	1 3/8-8 UN	5"	40	40
400	16"	1 1/2-8 UN	5 1/4"	40	40
450	18"	1 5/8-8 UN	5 3/2"	40	40
500	20"	1 5/8-8 UN	6"	48	48
600	24"	1 7/8-8 UN	6 3/4"	48	48
<b>Flansch mit Dichtleiste nach ASME B16.47</b>					
700	28"	Größen 28"-36" / DN 700-900 auf Anfrage			
750	30"				
800	32"				
900	36"				

# Montagesätze

## Class 150

DN	NPS	ISO 5211		Montagesatz
Class 150		Ventil	Antrieb	Pos.-Nr.
150	6"	F16	F10	MFXSP1F10V022A
			F12	MFXSP1F12V027A
			F14	MFXSP1F14V036A
			F16	MFXSP1F16V046A
			F25	MFXSP1F25V055A
200	8"	F16	F12	MFXTP1F12V027A
			F14	MFXTP1F14V036A
			F16	MFXTP1F16V046A
			F25	MFXTP1F25V055A
250	10"	F16	F14	MFXUP1F14V036A
			F16	MFXUP1F16V046A
			F25	MFXUP1F25V055A
300	12"	F25	F12	MFXVP1F12V027A
			F14	MFXVP1F14V036A
			F16	MFXVP1F16V046A
			F25	MFXVP1F25V055A
			F30	MFXVP1F30V075A
350	14"	F25	F16	MFXWP1F16V046A
			F25	MFXWP1F25V055A
			F30	MFXWP1F30V075A
400	16"	F25	F14	MFXXP1F14V036A
			F16	MFXXP1F16V046A
			F25	MFXXP1F25V055A
			F30	MFXXP1F30V075A
450	18"	F30	F16	MFXYP1F16V046A
			F25	MFXYP1F25V055A
			F30	MFXYP1F30V075A
500	20"	F30	F16	MFXZN3F16V046A
			F25	MFXZN3F25V055A
			F30	MFXZN3F30V075A
600	24"	F35	F16	MFXZN3F16V046A
			F25	MFXZN3F25V055A
			F30	MFXZN3F30V075A
			F35	MFXZN3F35R120A
700	28"	Größen 28"-36" / DN 700-900 auf Anfrage		
750	30"			
800	32"			
900	36"			

## Class 300

DN	NPS	ISO 5211		Montagesatz
Class 300		Ventil	Antrieb	Pos.-Nr.
150	6"	F16	F10	MFXSP1F10V022A
			F12	MFXSP1F12V027A
			F14	MFXSP1F14V036A
			F16	MFXSP1F16V046A
			F25	MFXSP1F25V055A
200	8"	F16	F12	MFXTP1F12V027A
			F14	MFXTP1F14V036A
			F16	MFXTP1F16V046A
			F25	MFXTP1F25V055A
250	10"	F16	F14	MFXUP1F14V036A
			F16	MFXUP1F16V046A
			F25	MFXUP1F25V055A
300	12"	F25	F12	MFXVP1F12V027A
			F14	MFXVP1F14V036A
			F16	MFXVP1F16V046A
			F25	MFXVP1F25V055A
			F30	MFXVP1F30V075A
350	14"	F25	F16	MFXWP1F16V046A
			F25	MFXWP1F25V055A
			F30	MFXWP1F30V075A
400	16"	F25	F14	MFXXP1F14V036A
			F16	MFXXP1F16V046A
			F25	MFXXP1F25V055A
			F30	MFXXP1F30V075A
450	18"	F30	F16	MFXYP1F16V046A
			F25	MFXYP1F25V055A
			F30	MFXYP1F30V075A
500	20"	F30	F16	MFXZN3F16V046A
			F25	MFXZN3F25V055A
			F30	MFXZN3F30V075A
600	24"	F35	F16	MFXZN3F16V046A
			F25	MFXZN3F25V055A
			F30	MFXZN3F30V075A
			F35	MFXZN3F35R120A
700	28"	Größen 28"-36" / DN 700-900 auf Anfrage		
750	30"			
800	32"			
900	36"			

## Class 600

DN	NPS	ISO 5211		Montagesatz
Class 600		Ventil	Antrieb	Pos.-Nr.
150	6"	F25	F16	MFCSR1F16V046A
			F25	MFCSR1F25V055A
			F30	MFCSR1F30V075A
200	8"	F25	F16	MFCTR1F16V046A
			F25	MFCTR1F25V055A
			F30	MFCTR1F30V075A
250	10"	F30	F25	MFUR1F25V055A
			F30	MFUR1F30V075A
			F35	MFUR1F35R120A
300	12"	F30	F25	MFVR1F25V055A
			F30	MFVR1F30V075A
			F35	MFVR1F35R120A
350	14"	F35	F30	MFWR1F30V075A
			F35	MFWR1F35R120A
			F40	MFWR1F40R160A
400	16"	F35	F30	MFXR1F30V075A
			F35	MFXR1F35R120A
			F40	MFXR1F40R160A
450	18"	F40	F30	MFYR1F30V075A
			F35	MFYR1F35R120A
			F40	MFYR1F40R160A
			F48	MFYR1F48R180A
500	20"	F48	F35	MFZR1F35R120A
			F40	MFZR1F40R160A
			F48	MFZR1F48R180A
600	24"	F48	F35	MF2R1F35R120A
			F40	MF2R1F40R160A
			F48	MF2R1F48R180A
700	28"	Größen 28"-36" / DN 700-900 auf Anfrage		
750	30"			
800	32"			
900	36"			

# Abmessungen für Armaturen mit Getriebebetätigung

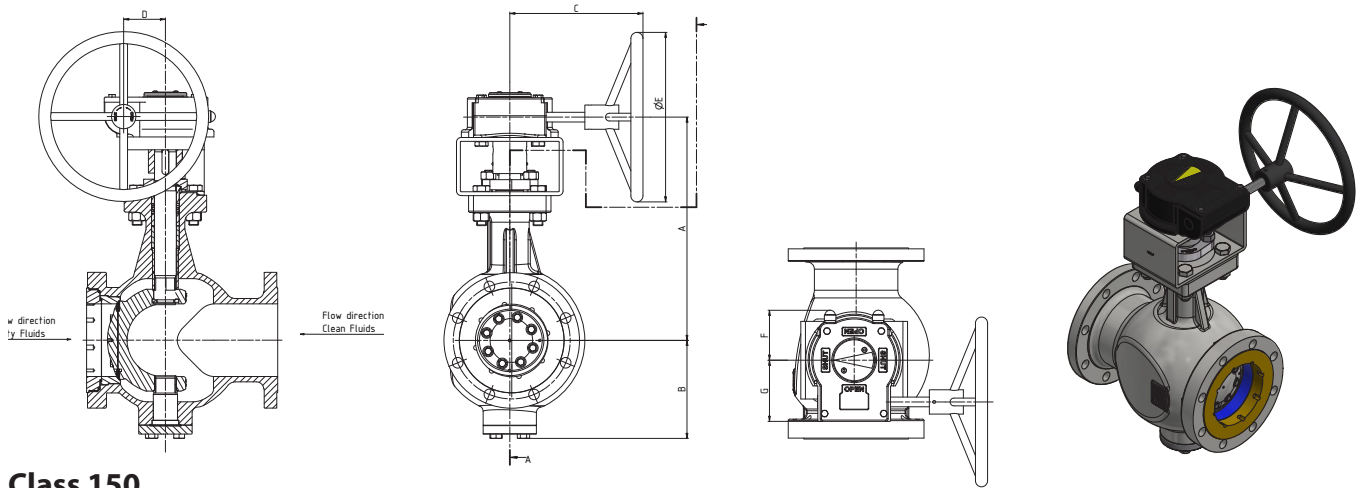

## Class 150

DN	NPS	Maße (Zoll)							Gewicht (lb)
		A	B	C	D	øE	F	G	
150	6"	17,1	8,0	10,4	3,4	9,8	3,9	5,0	246
200	8"	18,1	9,4	10,8	3,4	13,8	3,9	5,0	373
250	10"	22,5	11,6	12,4	4,1	13,8	4,3	5,8	581
300	12"	25,3	13,3	13,6	4,1	19,7	4,3	5,8	918
350	14"	25,4	15,6	12,5	5,1	13,8	5,6	5,9	1196
400	16"	29,5	17,0	14,8	5,1	9,8	5,6	7,1	1553
450	18"	33,5	19,0	15,6	5,5	11,8	6,9	7,8	2071
500	20"	35,8	21,0	17,1	7,2	11,8	8,2	9,4	2723
600	24"	38,2	23,0	17,3	7,2	13,8	8,2	9,4	3985

## Class 300

DN	NPS	Maße (Zoll)							Gewicht (lb)
		A	B	C	D	øE	F	G	
150	6"	17,1	8,0	10,4	3,4	9,8	3,9	5,0	407
200	8"	18,1	9,4	10,8	3,4	13,8	3,9	5,0	649
250	10"	22,5	11,6	12,4	4,1	13,8	4,3	5,8	1015
300	12"	25,3	13,3	13,6	4,1	19,7	4,3	5,8	1530
350	14"	25,4	15,6	12,5	5,1	13,8	5,6	5,9	1771
400	16"	29,5	17,0	14,8	5,1	9,8	5,6	7,1	2819
450	18"	33,5	19,0	15,6	5,5	11,8	6,9	7,8	4666
500	20"	35,8	21,0	17,1	7,2	11,8	8,2	9,4	5263
600	24"	38,2	23,0	17,3	7,2	13,8	8,2	9,4	10121

## Class 600

DN	NPS	Maße (Zoll)							Gewicht (lb)
		A	B	C	D	øE	F	G	
150	6"	24,4	8,6	14,8	5,1	9,8	5,6	7,1	493
200	8"	26,5	11,4	15,6	5,5	11,8	6,9	7,8	876
250	10"	28,7	13,4	17,3	7,2	13,8	6,7	9,4	1332
300	12"	33,3	14,6	17,8	8,2	9,8	8,2	11,2	1939
350	14"	34,6	17,2	18,0	8,2	11,8	8,2	11,2	2218
400	16"	36,0	18,7	20,1	10,1	15,7	9,3	13,8	3174
450	18"	40,4	20,7	27,0	18,0	19,7	11,6	19,0	5866
500	20"	48,2	22,6	30,1	17,3	27,6	15,7	24,8	6732
600	24"	51,4	26,5	30,1	17,3	31,5	15,7	24,8	12923

# Abmessungen für Armaturen mit Getriebebetätigung

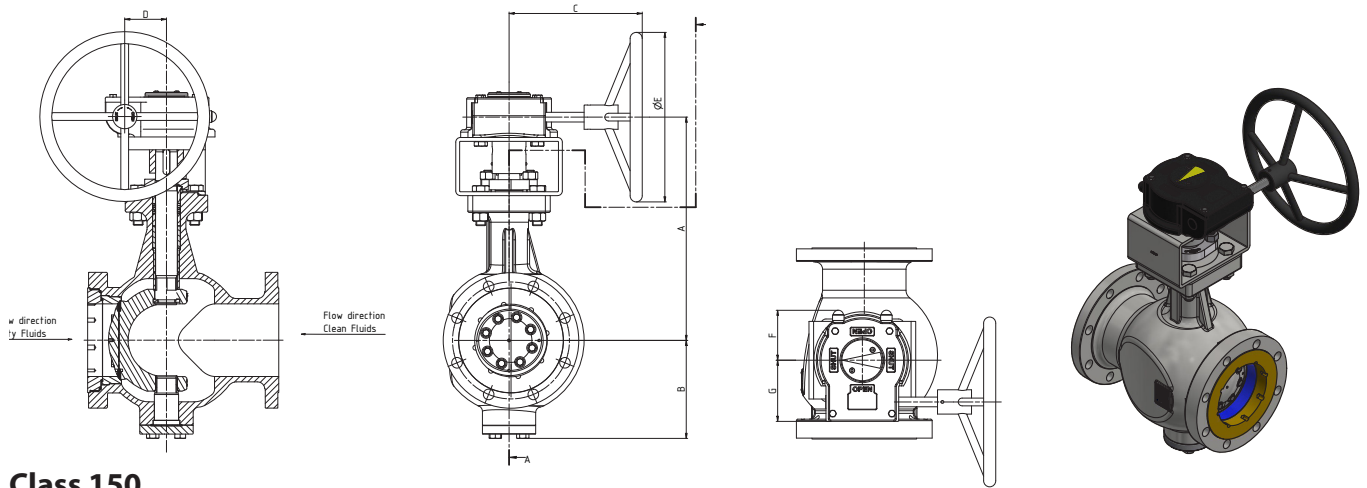

## Class 150

DN	NPS	Maße (mm)							Gewicht (kg)
		A	B	C	D	øE	F	G	
150	6"	435	202	265	86	250	100	126	112
200	8"	460	239	275	86	350	100	126	169
250	10"	572	296	316	105	350	110	148	263
300	12"	642	339	346	105	500	110	148	416
350	14"	646	397	318	130	350	142	150	543
400	16"	750	433	377	130	250	143	180	705
450	18"	850	483	395	140	300	175	197	940
500	20"	910	533	435	182	300	208	238	1236
600	24"	970	583	440	182	350	208	238	1808

## Class 300

DN	NPS	Maße (mm)							Gewicht (kg)
		A	B	C	D	øE	F	G	
150	6"	435	202	265	86	250	100	126	185
200	8"	460	239	275	86	350	100	126	294
250	10"	572	296	316	105	350	110	148	461
300	12"	642	339	346	105	500	110	148	694
350	14"	646	397	318	130	350	142	150	804
400	16"	750	433	377	130	250	143	180	1279
450	18"	850	483	395	140	300	175	197	2117
500	20"	910	533	435	182	300	208	238	2388
600	24"	970	583	440	182	350	208	238	4592

## Class 600

DN	NPS	Maße (mm)							Gewicht (kg)
		A	B	C	D	øE	F	G	
150	6"	620	218	377	130	250	143	180	224
200	8"	674	290	395	140	300	175	197	398
250	10"	730	340	440	182	350	170	238	605
300	12"	845	372	451	209	250	208	284	880
350	14"	880	438	456	209	300	208	284	1007
400	16"	915	475	511	256	400	235	350	1440
450	18"	1025	525	687	458	500	295	483	2662
500	20"	1225	575	765	440	700	398	631	3055
600	24"	1305	674	765	440	800	398	631	5864

# Produktkonfiguration

PRODUKT		ARMATURENTYP			WERKSTOFFGRUPPE		
Armatur	Größe	Druckstufe	Gehäuseausführung	Gehäusewerkstoff	Scheibenwerkstoff	Wellenwerkstoff	

## PRODUKT

Armatur
FK-TrieX

## ARMATURENTYP

Größe		
150	6"	06
200	8"	08
250	10"	10
300	12"	12
350	14"	14
400	16"	16
450	18"	18
500	20"	20
600	24"	24
700	28"	28
750	30"	30
800	32"	32
900	36"	36

Druckstufe	
Class 150	N
Class 300	P
Class 600	R

Gehäuseausführung	
Doppelflansch ASME B16.10 (Kugelhahn) lange Bauform	DL

## WERKSTOFF

Gehäusewerkstoff	
ASTM A216 Gr. WCB C-Stahl	A
ASTM A351 Gr. CF8M Edelstahl	B
ASTM A216 Gr. WCC Niedrig legierter Stahl	C
ASTM A352 Gr. LCB Tieftemperatur-C-Stahl	E
ASTM A352 Gr. LCC Tieftemperatur-C-Stahl	F
ASTM A216 Gr. WC6 Niedrig legierter Stahl	G
ASTM A494 Gr. N7M Hastelloy B-2	H
ASTM A494 Gr. M30H Monel 500	M
ASTM A995 Gr. 6A Superduplex	R
ASTM A216 Gr. WC9	W
Sonstige	X

Dichtring / TrieX Sitzkombination	
Titan Gr. 5/Graphit, Lamelle, Sitz: Stellite 6	T
ASTM A240 UNS S31803/Graphit, Lamelle, Sitz: Stellite 21	1
ASTM A240 UNS S31803/ Graphit, Lamelle, Sitz: Stellite 6	2
Sonstige	X

Scheibenwerkstoff:	
ASTM A216 Gr. WCB C-Stahl	A
ASTM A351 Gr. CF8M Edelstahl	B
ASTM A216 Gr. WCC Niedrig legierter Stahl	C
ASTM A352 Gr. LCB Tieftemperatur-C-Stahl	E
ASTM A352 Gr. LCC Tieftemperatur-C-Stahl	F
ASTM A216 Gr. WC6 Niedrig legierter Stahl	G
ASTM A494 Gr. N7M Hastelloy B-2	H
ASTM A494 Gr. M30H Monel 500	M
ASTM A995 Gr. 6A Superduplex	R
ASTM A216 Gr. WC9	W
Sonstige	X

Wellenwerkstoff:	
ASTM A564 Gr. 630 17-4 PH	A
ASTM 276 Gr. 431	B
ASTM A182 Gr. F55	C
ASTM A182 Gr. F51	D
ASTM A453 Gr. 660	E
ASTM A479 Gr. XM-19	F
ASTM UNS N06022	H
ASTM B865 Monel K500	M
Sonstige	X

# Produktkonfiguration

	DICHTLEISTE ANSCHLUSSFLANSCH	OPTIONEN STOPFBUCHSE/ PACKUNG / AUFBAUTEN			ANTRIEB	OPTIONEN
Dichtring / TrieX Sitzkombination	Flanschtyp	Stopfbuchspackung	Stopfbuchspackung	Ausführung Stopfbuchsflansch	Betriebsart	Optionen

## DICHTLEISTE ANSCHLUSSFLANSCH

Flanschtyp	
Glatte Dichtfläche FF nach ANSI B16.5 Glatte Dichtfläche FF nach ANSI B16.47, Serie A	6
Glatte Dichtleiste RF nach ANSI B16.5 Glatte Dichtleiste RF nach ANSI B16.47, Serie A	A
Dichtfläche mit breiter Nut nach ANSI B16.5	L
Sonstige	X

## OPTIONEN STOPFBUCHSE / PACKUNG / KOPFFLANSCH

Stopfbuchspackung	
Standard-Graphitpackung (ISO 15848 AH C03 / TA-Luft und API 641)	1
Graphitpackung für Hochtemperatur (TA-Luft)	5
Graphitpackung für Hochtemperatur (Non-FE / Non-TA-Luft / EN12266 A / API598)	6

Stopfbuchspackung	
Einfachpackung	A
Einfachpackung mit druckdichtem Lager	G
Einfachpackung mit Prüfanschluss und druckdichtem Lagerschutz	R
Sonstige	X

Stopfbuchsflansch	
Standardausführung	A
Sonstige	X

## ANTRIEB

Betriebsart	
Elektrisch	E
Freies Wellenende	F
Handhebel, Getriebe	G
Hydraulisch	H
Montagesatz	M
Pneumatisch, Schwenkantrieb	R
Pneumatisch, Scotch-Yoke	Y
Sonstige	X

## OPTIONEN

Optionen	
Nace MR0175	N5
NACE MR0103	N3
Hochtemperatur bis 550°C	H5
Hochtemperatur bis 700°C	H7
Alle innenliegenden Bauteile aus Edelstahl 316	SS
Nach DT91 Norm	D9
Heizmantel	HJ
Mit CE-Kennzeichnung	CE
Geprüft nach EN15848-2	EN 15848-2

**CRANE**<sup>®</sup>

---

**CRANE CHEMPHARMA & ENERGY**

Xomox International GmbH & Co. OHG  
Marburger Str. 364  
57223 Kreuztal, Deutschland  
Tel.: +49 2732 520 00

4526 Research Forest Drive,  
Suite 400  
The Woodlands  
Texas 77381, U.S.A.  
Tel.: +1 936 271 6500

ARMATURE d.o.o.  
Koroška cesta 55  
2366 Muta (Slowenien)  
Tel.: +386 2 87 70 500  
quote-armature@cranecpe.com

---

Crane Co. und die zugehörigen Tochtergesellschaften übernehmen keine Verantwortung für etwaige Fehler in Katalogen, Broschüren, sonstigen Druckerzeugnissen und Informationen auf ihren Webseiten. Crane Co. behält sich das Recht vor, seine Produkte ohne Ankündigung zu ändern. Sofern nicht anders angegeben, gilt dies auch für Produkte, die bereits bestellt wurden, sofern die Änderungen vorgenommen werden, ohne dass eine Änderung an bereits vereinbarten Spezifikationen erforderlich wird. Alle eingetragenen Warenzeichen in dieser Dokumentation sind Eigentum von Crane Co. oder deren verbundener Unternehmen. Crane sowie die Marken von Crane und deren Schriftzüge (CENTER LINE<sup>®</sup>, COMPAC-NOZ<sup>®</sup>, CRANE<sup>®</sup>, DEPA<sup>®</sup> & ELRO<sup>®</sup>, DOPAK<sup>®</sup>, DUO-CHEK<sup>®</sup>, FLOWSEAL<sup>®</sup>, GYROLOK<sup>®</sup>, GO REGULATOR<sup>®</sup>, HOKE<sup>®</sup>, JENKINS<sup>®</sup>, KROMBACH<sup>®</sup>, NOZ-CHEK<sup>®</sup>, PACIFIC VALVES<sup>®</sup>, RESISTOFLEX<sup>®</sup>, REVO<sup>®</sup>, SAUNDERS<sup>®</sup>, STOCKHAM<sup>®</sup>, TEXAS SAMPLING<sup>®</sup>, TRIANGLE<sup>®</sup>, UNI-CHEK<sup>®</sup>, VALVES<sup>®</sup>, WESTLOCK CONTROLS<sup>®</sup>, WTA<sup>®</sup> und XOMOX<sup>®</sup>) sind eingetragene Warenzeichen von Crane Co. Alle Rechte vorbehalten.