



**NEW!** HIGH  $C_v$  VALVE PERMITS LINE SIZE REDUCTION

CRANE® FK-TrieX™  
Full Port Triple Offset Isolation  
Valves For Severe Service

CRANE®

 [www.cranecpe.com](http://www.cranecpe.com)

## Features and Benefits

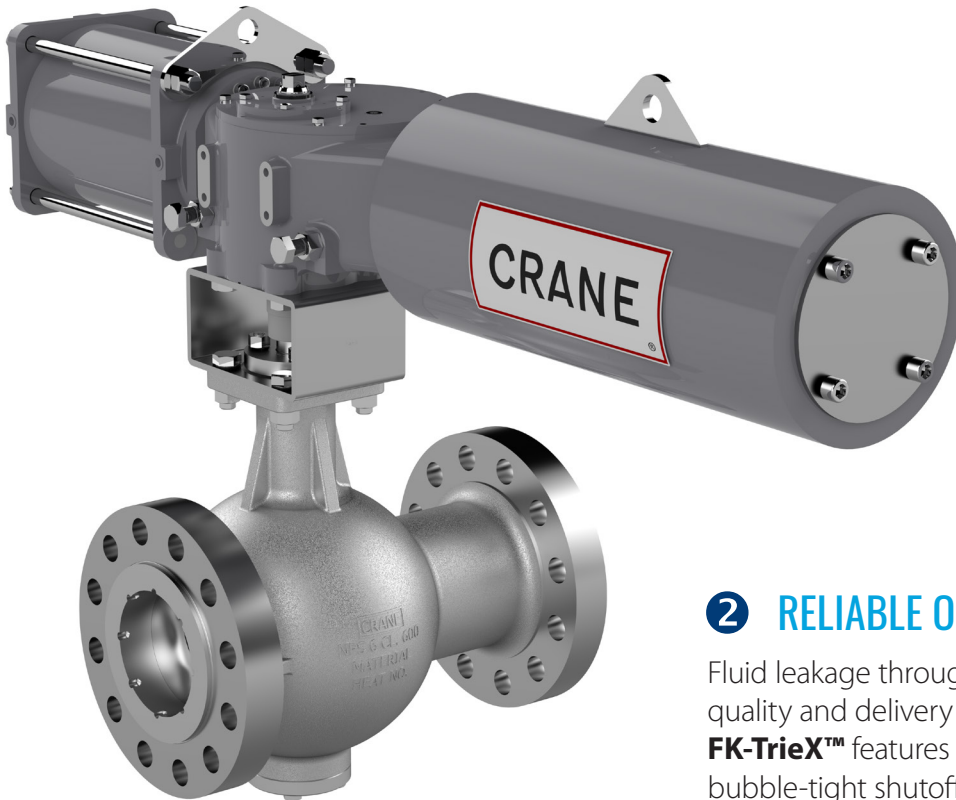

### 1 SAFETY



With **CRANE® FK-TrieX™** severe service isolation valves, you can run safe and environmentally responsible operations, prevent high consequence incidents including fire, explosion and leakages, and eliminate risk to the health and safety of employees, assets and communities. The design of the **CRANE® FK-TrieX™** minimizes fugitive emissions that is not only a safety risk but that also contribute (5.2 ~ 12%) to global greenhouse gas emissions.

### 2 RELIABLE OPERATIONS



Fluid leakage through the valve can impact the quality and delivery of your products. The **CRANE® FK-TrieX™** features a repeatable, bidirectional, bubble-tight shutoff that can help you achieve higher product output by reducing unplanned shutdowns from valve failures and by reducing planned valve maintenance time by more than 50%. When necessary, the ability to field-repair the seats ensures minimal downtime.

### 3 LOW OVERALL COST



The **CRANE® FK-TrieX™** enhances the long term value of your investment. Relative to existing full port isolation technologies, you can realize both upfront and long-term cost savings in the form of smaller actuators, 20% lower structural support cost, >50% reduced cost of planned maintenance due to the modular seat design and minimal product wastage costs. The high Cv of the **CRANE® FK-TrieX™** permits reduction in line size when replacing butterfly valves.

# Design Advantages

The **CRANE® FK-TrieX™** is an isolation valve that features industry-leading Cv, and provides a bi-directional and frictionless bubble-tight shutoff with unparalleled reliability at a low overall cost. This valve design takes the best features of the severe service ball valve portfolio and harnesses the economy and reliability of a triple offset valve platform to develop a powerful, versatile hybrid. The **CRANE® FK-TrieX™** can be defined as a full port triple offset valve, and provides:

1. **HIGH RELIABILITY:** Triple offset geometry, with a longer-lasting seat and seal
2. **HIGH TEMPERATURE RESISTANCE:** API 607 fire-safe, temperature limits up to 1,000 degrees Fahrenheit
3. **ZERO LEAKAGE:** API 6D and API 598 when you need critical absolute shutoff
4. **FULL BORE OPERATION:** Patent-pending proprietary disc design permits greater throughput, with Cv levels comparable to ball valves
5. **LOW OPERATING TORQUE:** Operating torque comparable with TOVs and much lower than quarter-turn metal seated full port ball valves
6. **LOW WEIGHT:** Compared to other valves of equivalent flow performance, with 25% lower bare stem weights
7. **SOLIDS HANDLING:** Capable of handling up to 50% solids
8. **REPAIRABLE / REPLACEABLE SEATS & SEALS:** Innovative design permits resurfacing, modular replacement and field repair, limiting your investment, reducing downtime, and increasing the life span of valve
9. **EASIER AUTOMATION:** Lower torque requirement permits smaller, lighter automation packages with rapid shut / open times for ESD specifications

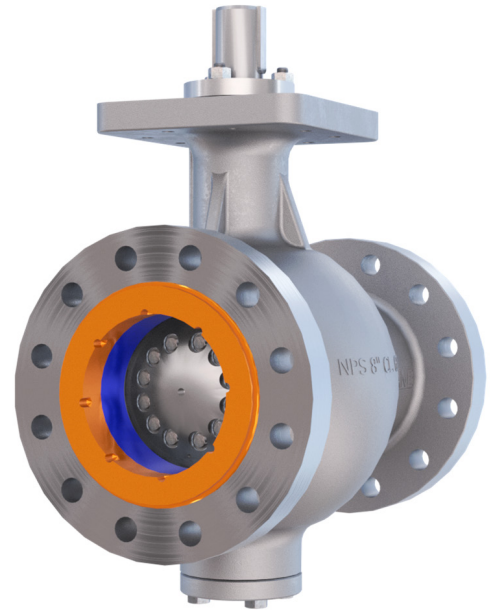

ADVANTAGES VS OTHER VALVE TYPES				
	Ball Valve Including Rising Stem	Gate Valve	Butterfly Valve	Plug Valve
	Raised Face and Flanged End			
REPLACEMENT POSSIBLE	✓	✓	✓	✓
CRANE® FK-TrieX™ BENEFITS	<ul style="list-style-type: none"> <li>• Reduced torque</li> <li>• Lower cost of ownership</li> <li>• Superior seat tightness</li> <li>• Trouble-free reparability</li> </ul>	<ul style="list-style-type: none"> <li>• Improved overall sealing</li> <li>• Superior fugitive emissions control</li> </ul>	<ul style="list-style-type: none"> <li>• Increased flow / minimal pressure drop</li> <li>• Trouble-free reparability</li> </ul>	<ul style="list-style-type: none"> <li>• Reduced torque</li> <li>• Lower cost of ownership</li> </ul>

# Product Overview

### Materials of Construction

- Standard: A216 Gr. WCB, A351 Gr. CF8M; LCC, Monel®
- Options upon request: Duplex, Superduplex, LCB, WC6, CF3M, Inconel®, Hastelloy®, Alloy 20

### Size Range

- 6" up to 36" in a single piece cast body design

### Pressure Ratings

- ASME Class 150, 300, 600

### Temperature Range

- -76°F up to 1022°F; -60°C up to 550°C, depending on material

### Body Configurations

- ASME B16.10: Double Flanged Long (ball valve)

### Standard Features and Compliance

- API 6D compliant
- Fugitive Emissions Control per ISO 15848-1 AH CO3 & API 641
- Fire Safe Design per API 607
- ASME B16.10: Double Flanged Long (ball valve)
- Cavity-less self cleaning design
- Pressure-Tight Bearing Design

### Special Options

- Heating Jacket
- Design compliant to NACE MR0175 and NACE MR0163

DN (mm)	NPS (inch)	Class 150	Class 300	Class 600
150	6"	●	●	●
200	8"	●	●	●
250	10"	●	●	●
300	12"	●	●	●
350	14"	●	●	●
400	16"	●	●	●
450	18"	●	●	●
500	20"	●	●	●
600	24"	●	●	●
700	28"	●	●	●
750	30"	●	●	●
800	32"	●	●	●
900	36"	●	●	●

● = available

# Design Features

### Full Bore Operation

Patent-pending proprietary disc design permits greater throughput, with Cv levels comparable to ball valves. Suitable for piping integrity gauges.

### Polygon Geometry

Stem-to-disc engagement safely enables the most effective torque transmission.

### Repairable/ Replaceable Seats & Seals

Innovative design permits resurfacing, modular replacement, and field repair, reducing downtime and increasing life span of valve.

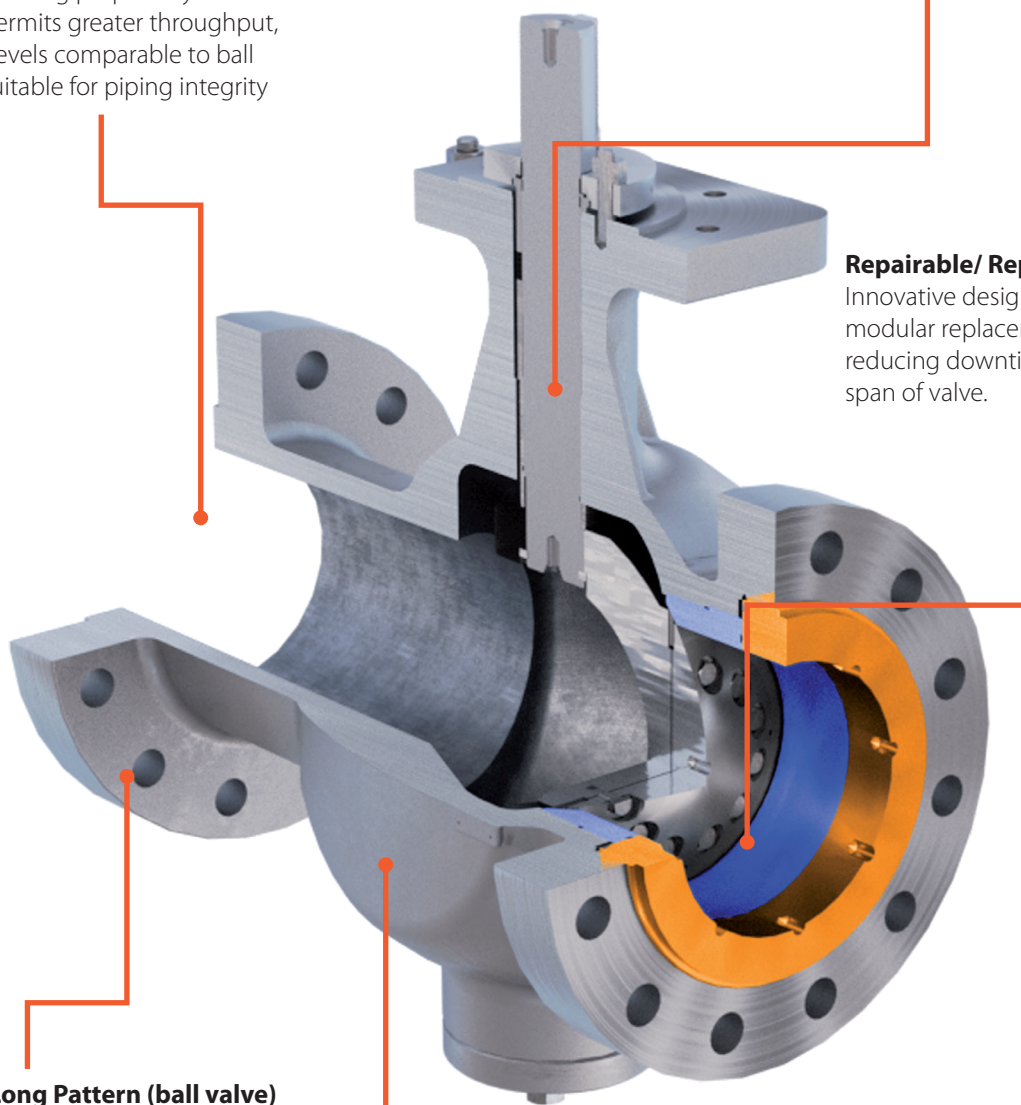

### B16.10 Long Pattern (ball valve)

Engineered with the same face-to-face dimensions as other technologies and complying with the standard ASME B16.10 long pattern (ball valve), means the **CRANE® FK-TriEX™** can be readily swapped with other standard valves, without modifications to the system.

### Single-Piece Body

Single-piece body design eliminates leak paths minimising the risk of atmospheric leaks.

## Design Features

### API 6D Compliant Full Bore Design

- With the API 6D standard full-bore design, Pipeline Inspection Gauges (PIGs) and cleaning scrapers can pass through the valve in the fully open position, allowing the system to be cleaned without needing to remove the valve. This standard full-bore architecture affords an optimal flow profile with high Cv and low-pressure drop across the valve.



### Polygon Design

- The polygon profile safely enables the most effective torque transmission.
  - Provides higher safety against stem deformation
  - Reduces stress load into disc
- Ensures proper alignment

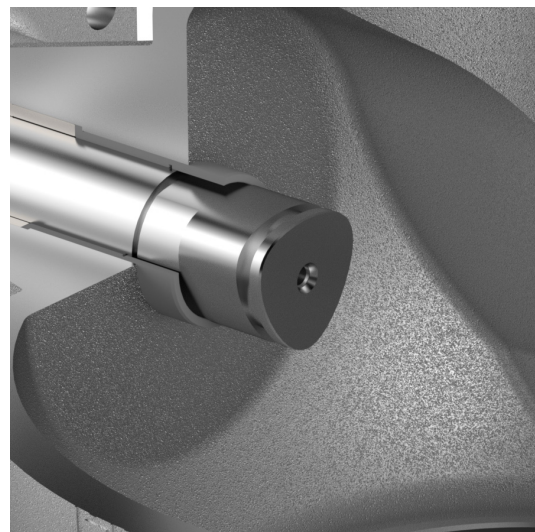

### Seat and Laminated Seal

- Utilizing high modulus materials and high temperature graphite, the full triple offset geometry provides durable and reliable operation with zero leakage.
- With the modular seat design, the seat and laminate seals can be replaced individually, without having to replace the entire valve, further reducing maintenance costs. Moreover, these replacements can be carried out in the field, eliminating the need to ship the valve to service centers.
- The replaceable stellite welded seat with an RC hardness rating of 40 (powder plasma Stellite) and flexible laminate seals provide excellent shutoff and approximately double the life of regular stainless-steel seats.

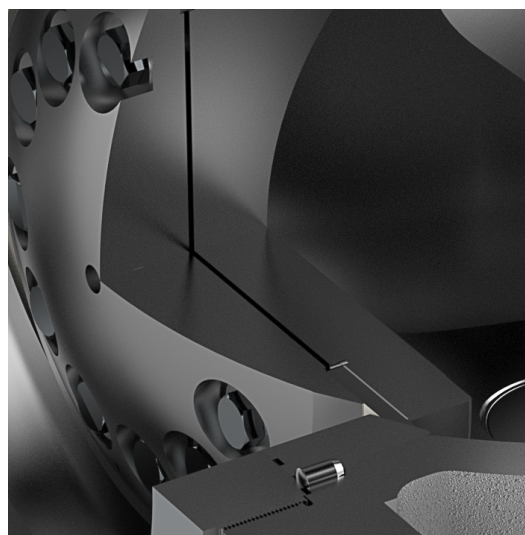

### Proprietary Disc Shape

- This unique disc shape is the foundation to generating the first offset of the triple offset sealing element, providing full port and torque assisted seating resulting in API 6D zero leakage.
- Wear typically attributable to spring force and other impinging forces on the seat of the valve is absent in the **CRANE® FK-TrieX™**.



## Design Features

### Single-Piece Body

- The single-piece body design reduces its weight by up to 10%, decreasing structural support costs.
- It also eliminates leak paths between body flanges that is typical of split body design.

### Double Flanged Long Design (ball valve)

- Double flanged long (ball valve) in accordance with ASME B16.10, minimizing the need for piping changes when replacing alternative technologies

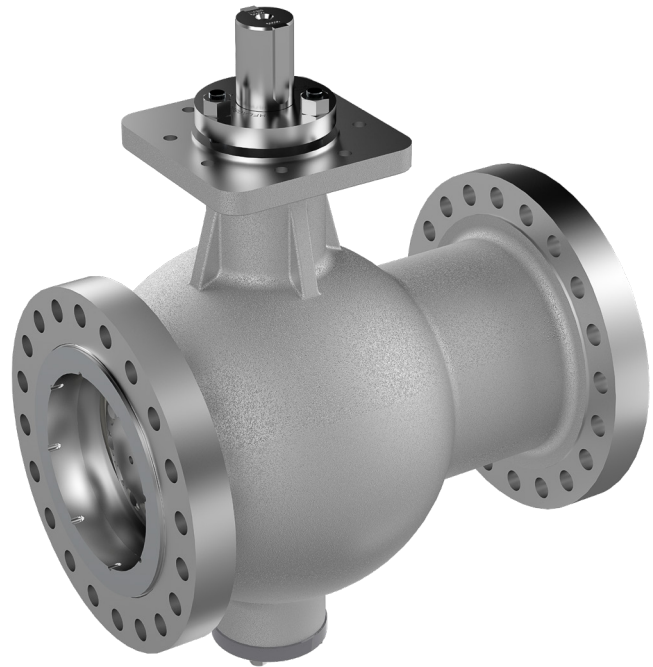

### Fugitive Emissions Control and Fire Safety

- The **CRANE® FK-TrieX™** meets the highest standards, with certifications to API 641 and ISO 15848 AH C03 at 750 degrees Fahrenheit. The stem seal technology is built on the same innovative platform as the CRANE® FKX9000, providing critical performance in an uncompromising design.
- The **CRANE® FK-TrieX™** also meets the rigorous standards of the API 607 fire test for quarter-turn valves confirming its pressure-containing capability during and after the test.

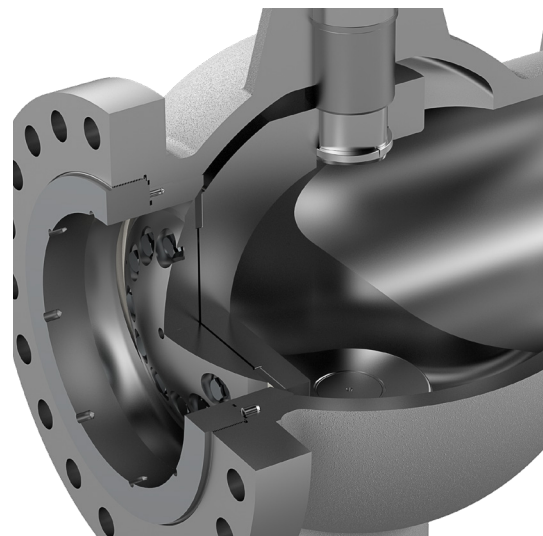



The **CRANE® FK-Triex™** offers an effective solution for severe service applications with the ability to perform under demanding conditions while offering unmatched safety, reliability of operations, and a greatly reduced startup and lifetime cost.

FUNCTION	
ON / OFF	●
Throttling	●
Modulation System	●

MEDIA TYPES	
Clean Liquids & Gases	●
Dirty Liquids & Gasses	●
Corrosive Liquids & Gases	●
Hazardous Liquids	●
Viscous Liquids	●
Abrasive Slurries	●
High Temperatures	●
Vacuum Service	●

APPLICATION REQUIREMENTS	
Extended Service Life	●
Low Torque	●
Full Port (API 6D)	●
Fugitive Emissions Control	●
Reduced Maintenance	●
Bi-directional Zero Leakage	●
Sizes	6"-36" / DN 150-900
Pressure Range	Class 150-600
High Temperature	1022°F / 550°C
Low Temperature	-76°F / -60°C

● Well Suited    ● Limited Application

## Industries

- Oil & Gas
- Chemical & Petrochemical Plants
- Hydrocarbons Storage & Transportation
- Refineries
- Offshore Platforms
- Pulp & Paper
- Steel Mills
- Sugar Mills
- Desalination Plants
- Water Treatment & Distribution
- Power Generation
- District Heating

## Processes

- Hydrocarbons
- Hydrogen
- Oxygen
- Hot Gases
- Sulphur (Tail Gas)
- Chlorinated Solvents
- Flare Gas
- Chemical Solvents
- Highly Sensitive Compounds
- Steam (Saturated & Superheated)

## Automation

The **CRANE® FK-TrieX™** uses quarter turn stem technology and is therefore ideally suited for easy automation. Using traditional actuation and only rotary movement, the **CRANE® FK-TrieX™** can easily achieve SIL 3 ratings on full automation packages. Utilizing quarter turn actuation devices significantly reduces the complexity and cost of automated valves. The **CRANE® FK-TrieX™** is an excellent solution in emergency shut down valves, safety interlock systems and other critical automated isolation valve requirements.



### Gears

Gear boxes are for manual actuation of valves. They provide a travel of 90° for simple on/off applications. The self-jamming worm gear prevents involuntary movements. Several accessories can be equipped like a padlock, chainwheel and limit switches.



### Scotch & Yoke Actuators

Scotch & Yoke are available as pneumatic or hydraulic actuators. The linear movement of the pressure operated piston is transferred into a rotation by a yoke. These actuators can be used for on/off application and the special torque characteristic makes them ideal for control applications. They have an increased torque range compared to Rack & Pinion actuators. Scotch & Yoke actuators are available as double-acting actuators and single-acting spring return actuators for safety reasons. Several accessories can be equipped like solenoid valves, smart positioners, limit switches, etc.

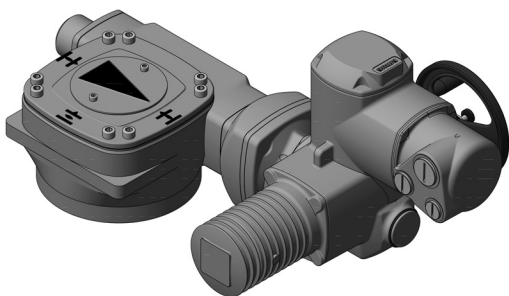

### Electric Actuators

Electric actuators are mostly a combination of a gear box and an electrical motor. Electric power generates a torque which operates the valve. These actuators are flexible and economical. They can be installed where no air supply is available. They can also be equipped with several electrical accessories, like special control units, to make them smart and bus interfaces.

**THE CRANE® FK-TRIEX™ IS AN INNOVATIVE SOLUTION THAT PROVIDES BI-DIRECTIONAL BUBBLE TIGHT SHUTOFF, HIGH RELIABILITY, SUPERIOR FUGITIVE EMISSIONS CONTROL, EASE OF SERVICEABILITY, LESS WEIGHT, LOW TORQUE ACTUATION, AND LOW TOTAL COST OF OWNERSHIP.**



**CRANE**<sup>®</sup>

---

**CRANE CHEMPHARMA & ENERGY**

Xomox International GmbH & Co. OHG  
Marburger Str. 364  
57223 Kreuztal, Germany  
Tel: +49 2732 520 00

4526 Research Forest Drive,  
Suite 400  
The Woodlands  
Texas 77381, U.S.A.  
Tel: +1 936 271 6500

---

Crane Co., and its subsidiaries cannot accept responsibility for possible errors in catalogues, brochures, other printed materials, and website information. Crane Co. reserves the right to alter its products without notice, including products already on order provided that such alteration can be made without changes being necessary in specifications already agreed. All trademarks in this material are the property of the Crane Co. or its subsidiaries. The Crane and Crane brands logotype (CENTER LINE<sup>®</sup>, COMPAC-NOZ<sup>®</sup>, CRANE<sup>®</sup>, DEPA<sup>®</sup> & ELRO<sup>®</sup>, DOPAK<sup>®</sup>, DUO-CHEK<sup>®</sup>, FLOWSEAL<sup>®</sup>, GYROLOK<sup>®</sup>, GO REGULATOR<sup>®</sup>, HOKE<sup>®</sup>, JENKINS<sup>®</sup>, KROMBACH<sup>®</sup>, NOZ-CHEK<sup>®</sup>, PACIFIC VALVES<sup>®</sup>, RESISTOFLEX<sup>®</sup>, REVO<sup>®</sup>, SAUNDERS<sup>®</sup>, STOCKHAM<sup>®</sup>, TEXAS SAMPLING<sup>®</sup>, TRIANGLE<sup>®</sup>, UNI-CHEK<sup>®</sup>, VALVES<sup>®</sup>, WESTLOCK CONTROLS<sup>®</sup>, WTA<sup>®</sup>, and XOMOX<sup>®</sup>) are registered trademarks of Crane Co. All rights reserved.