



brands you trust.

TECHNICAL DATASHEET
CRANE® Cast Steel Valves



Crane ChemPharma & Energy

www.cranecpe.com

Index

Ordering Information.....	3
Materials	4
Identification.....	5
Gate Valve Features	6
NACE Trim Steel Valves.....	12
Globe Valve Features.....	13
Swing Check Valve Features.....	19
Pressure/Temperature Ratings.....	25
Cv / Kv Values.....	28

Crane also manufactures bronze ball valves, iron wafer and lug butterfly valves, bronze and iron gate globe and check valves, and alloy valves. Brochures and catalogs are available on request.

FIGURE NO.	VALVE TYPE	PRESSURE CLASS	CONNECTIONS	SIZE RANGE	PAGE NO.
47	Gate Valve	150	Flanged	2" – 24" (50 – 600 mm)	7
47½			Butt-Weld		
33	Gate Valve	300	Flanged	2" – 24" (50 – 600 mm)	8
33½			Butt-Weld		
76	Gate Valve	600	Flanged	2" – 24" (50 – 600 mm)	9
76½			Butt-Weld		
83	Gate Valve	900	Flanged	2" – 24" (50 – 600 mm)	10
83½			Butt-Weld		
87	Gate Valve	1500	Flanged	2" – 16" (50 – 400 mm)	11
87½			Butt-Weld		
143	Globe Valve	150	Flanged	2" – 16" (50 – 400 mm)	14
143½			Butt-Weld		
151	Globe Valve	300	Flanged	2" – 16" (50 – 400 mm)	15
151½			Butt-Weld		
171	Globe Valve	600	Flanged	2" – 16" (50 – 400 mm)	16
171½			Butt-Weld		
183	Globe Valve	900	Flanged	2" – 12" (50 – 300 mm)	17
183½			Butt-Weld		
189	Globe Valve	1500	Flanged	2" – 8" (50 – 200 mm)	18
189½			Butt-Weld		
147	Swing Check Valve	150	Flanged	2" – 24" (50 – 600 mm)	20
147½			Butt-Weld		
159	Swing Check Valve	300	Flanged	2" – 24" (50 – 600 mm)	21
159½			Butt-Weld		
175	Swing Check Valve	600	Flanged	2" – 20" (50 – 500 mm)	22
175½			Butt-Weld		
187	Swing Check Valve	900	Flanged	2" – 12" (50 – 300 mm)	23
187½			Butt-Weld		
199	Swing Check Valve	1500	Flanged	2" – 10" (50 – 250 mm)	24
199½			Butt-Weld		

How to Specify and Order the Correct Valves

Care should be taken to select the most suitable steel valve for your service(s). Exact specification of each valve should be made to avoid ambiguity when requesting quotations or ordering the product.

Size

Nominal size of the pipeline into which the valve will be placed must be determined. Comprehensive data on flow characteristic and pipe properties are contained in the Engineering Data Catalog.

Valve Material

The following facts should be considered in determining the correct valve material.

- The media to be controlled.
- The temperature of the media.
- The possible extraordinary stresses affecting the valve.
- Safety standards and/or piping codes.

Type of Valve

A few minutes spent in reading some simple valve facts on pages 4 will prove helpful.

Pressure/Temperature Rating

Please pay careful attention that the PRESSURE/TEMPERATURE RATINGS shown on pages 25-27 in this catalog are in keeping with the requirements of the service.

Valve End Connections

Considerations as to pipeline integrity, future maintenance, corrosion factors, field assembly, weight and safety should be given in determining the method of connecting the valve in the pipeline.

CAUTION: When servicing, disassembling or disposing of valves containing asbestos gaskets or packing, avoid breathing dust or fibers from these parts. Disposal of asbestos and asbestos related products should comply with local, state and federal laws and regulations.

Ordering Information

Designate the valve size and the complete catalog number, including prefix and suffix letters, when applicable, to identify regular cataloged items as described on the following pages.

Any special requirements such as Gear operation, Motor operation, Hydraulic or Pneumatic Cylinder operation, Anti-friction bearing yoke sleeve, By-pass, drain, etc. must also be specified on purchase orders.

Examples

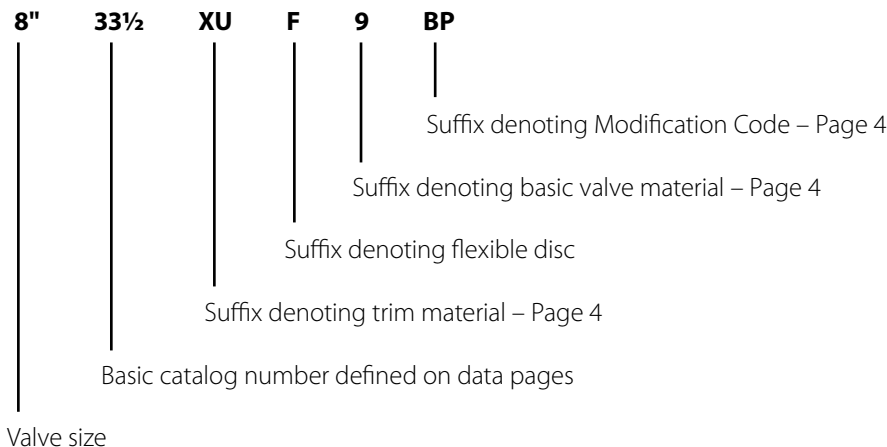

Note: L prefix refers to API-624 compliance

NOTE: In keeping with our policy of continuous product improvement, we reserve the right to institute changes in design, material, dimensions, and specifications without notice and without incurring any obligation to make such changes and modifications on the product previously or subsequently sold.

Materials of Construction

Steel bolted bonnet valves described in this catalog are typically manufactured of carbon steel. When specified, the valves are available in the alloys shown below which are suitable for steam, water, oil, oil vapor, gas and general services. Please contact factory or customer service for availability and material breakdowns.

Body and Bonnet or Cap Materials

Part No. Suffix	ASTM Classification	Material Classification	Service Conditions
None	A216 WCB	Carbon Steel	For service up to 800°F (426°C) where corrosion and oxidation are not a factor. ^{(1) (4) (5)}
6	A217 WC6	1 ¼ CR, ½ Mo	For service up to 1000°F (537°C). ^{(2) (3) (4) (5)}
9	A217 WC9	2 ¼ CR, 1 Mo	For service up to 1100°F (593°C) where good creep strength is required. ^{(2) (3) (4) (5)}
5	A217 C5	5% CR, ½ Mo	For service up to 1200°F (649°C). Best corrosion and oxidation resistance plus high creep strength are required. ⁽²⁾
12	A217 C12	9% CR, 1 Mo	For service up to 1200°F (649°C). Best corrosion and oxidation resistance than other grades. ⁽²⁾
2	A352 LCC	Low Carbon Steel	For service from -20°F to 650°F (-33°C to 343°C). This material must be quenched and tempered to obtain tensile and impact properties needed at subzero temperatures.
8M	A351 CF8M	Stainless Steel (316)	For services up to 1000°F (537°C), where corrosion and oxidation resistance are desired.
8	A351 CF8	Stainless Steel (304)	For services up to 1000°F (537°C), where corrosion and oxidation resistance are desired, but lower costs than CF8M and slightly lower material strengths and corrosion resistance can be tolerated.

(1) Upon prolonged exposure to temperatures above 800°F (426°C), the carbide phase of carbon steel may be converted to graphite. Permissible, but not recommended for prolonged usage above 800°F (426°C).

(2) Flanged end valves rated to 1000°F (537°C).

(3) Considerations should be given to the possibility of excessive oxidation (scaling) when used above 1050°F (565°C).

(4) Product used within the jurisdiction of Section 1 Power Boilers of the ASME Boiler and Pressure Vessel code is subject to the same temperature limitations as specified in that document.

(5) Product used within the jurisdiction of Power Piping, ASME Code for Pressure Piping B31.1, is subject to the same maximum temperature limitations placed upon the material in paragraph 124.2.

Trim Material

Part No. Suffix	API Trim Number	Nominal Trim	Seating Surfaces	Stem Material	Temperature
X	1	F6 / F6 (1)	13 Cr ASTM A217 (CA15)	13 Cr (410)	1100°F (593°C)
UF*	5	HF / HF (2)	CoCr	13 Cr (410)	1200°F (649°C)
A	9	NiCu Alloy / NiCu Alloy	NiCu Alloy	NiCu Alloy	450°F (232°C)
L	10	316 / 316 (3)	316 SS	316 SS	850°F (454°C)
XUF*	8	F6 / HF (1) (2)	13 Cr ASTM A217 (CA 215) CoCr	13 Cr (410)	1100°F (593°C)
AUF*	11	NiCu Alloy / HF (2)	NiCu Alloy CoCr	NiCu Alloy	450°F (232°C)
LUF*	12	316 / HF (3) (2)	316 SS CoCr	316 SS	850°F (454°C)

(1) 13% Chromium AISI Type 410 Stainless Steel.

(2) Hard Facing CoCr is weld deposited Cobalt base alloy.

(3) Austenitic Stainless Steel is a Ni-Cr-Mo stainless steel in the AISI Type 316 category.

*F denotes Flex Wedge (only applies to Gate Valves).

Valve Modification Suffix Identification

S.I.	Description	S.I.	Description	S.I.	Description	S.I.	Description	
TD	Drain, Drill and Tap	ST	Special Trim	SP	Special Paint	OV	(1) Gear	(4) Pneumatic
BP	Bypass	BW	Special Butt-Weld End Prep	LD	Locking Device		(2) Chainwheel	(5) Hydraulic
PG	Special Packing and/or Gasket	RJ	Ring Joint	LR	Lantern Ring		(3) Electric	(6) Other

NiCu alloy commonly referred to as Monel® a registered trademark of Special Metals Corporation.

Installation, Marking and Identification

When purchasing valves, reference should also be made to MSS SP92 "Valve Users Guide." Inquiries relating specifically to Crane products may be referred to our factory or customer service department.

Marking and identification of Crane steel valves conforms to ASME B16.34 and MSS SP-25.

It is important to properly identify valves in service to allow for the ordering of replacement parts or address questions or concerns relating to our products. Body markings and information shown on the identification plate helps to properly identify valves, allowing timely and accurate responses to such inquiries.

Integrally cast body marking data includes the following information and helps to provide traceability:

- Crane logo
- Pressure class
- Valve size
- "Steel" symbol for the grade of material (i.e., WCB for carbon steel)
- Heat number – on body and bonnet (cast or stamped)
- Individual serialization

The body markings are supplemented by an identification plate which, depending on valve type and size, is mounted in the most practicable position. Tag location for gate and globe valves is typically on the valve yoke or body/bonnet flange. Check valve tags are typically mounted on the rim of the cap.

Identification plates bear the following information:

- Catalog number
- Valve size
- Body material
- Disc material
- Stem material
- Seat and trim material
- Pressure and temperature rating

Product Marking

I.D. Tag Marking Information

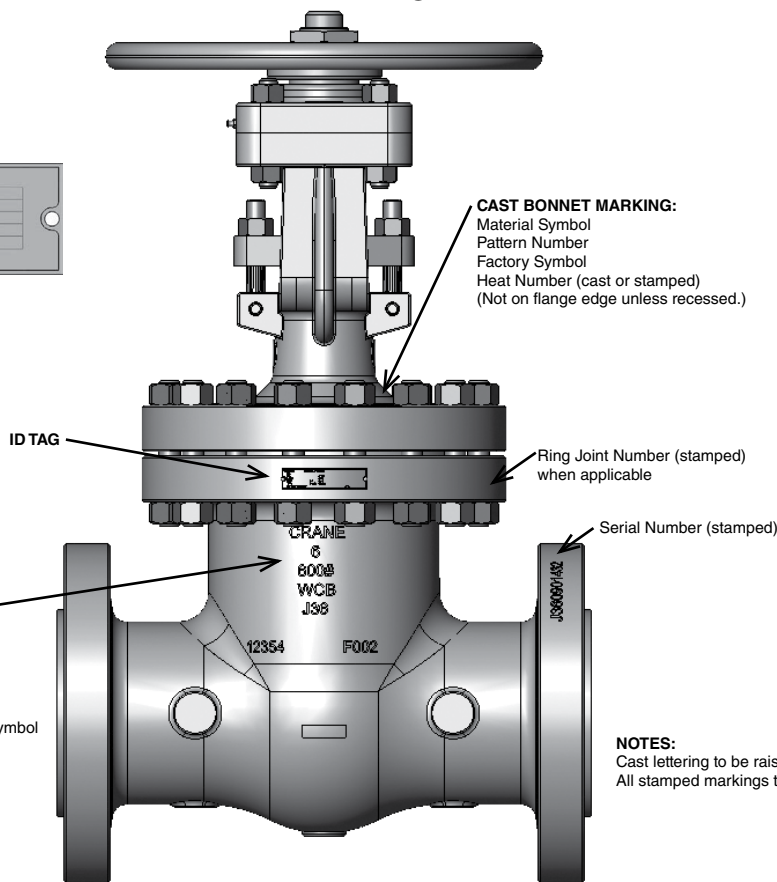
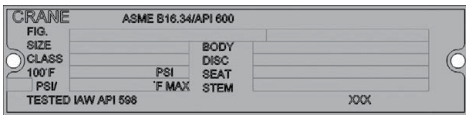

CAST BODY MARKING:
 CRANE
 Size 2, 2½, 3, 4...
 Class 150, 300, 600, 900
 Material Material Grade Symbol
 Factory ID Manufacturer's Identification Symbol
 Pattern No. XXXXX (Optional)
 Foundry Symbol YYYY

CAST BONNET MARKING:
 Material Symbol
 Pattern Number
 Factory Symbol
 Heat Number (cast or stamped)
 (Not on flange edge unless recessed.)

Ring Joint Number (stamped)
 when applicable

Serial Number (stamped)

NOTES:
 Cast lettering to be raised Gothic type.
 All stamped markings to be low stress.

Overview Class 150, 300, 600, 900 & 1500 Gate Valves

Features

Flexible Wedge

- Compensates for deformation of body due to pipe stresses.
- Will not stick when valve is closed hot and allowed to cool.

Welded-in Seat Ring

- Seat ring is seal welded to eliminate leak path.

Standards

These valves comply with the applicable requirements of the following standards:

- API 624
- API 622
- API 600
- API 598
- ASME B16.34
- ASME B16.25
- ASME B16.10
- ASME B16.5

Inspection Policy for Crane Valves

Every Crane cast steel valve is subjected to a 100% pressure test according to API 598 requirements. Manufacturer's material test reports and Inspection and Test Certifications are available upon request. Some of the additional inspections and tests performed are:

- Random Radiograph Inspection of Body and Bonnet Castings to ASME B16.34 Appendix B
- Random Chemical Composition and Mechanical Properties Verification of Fasteners to ASTM A-193/A-194
- Liquid Penetrate Inspection of Seat Rings
- Visual Inspection of Casting to MSS SP-55 and MSS SP-112
- Receiving, In-Process, and Final Dimensional Inspections to Relevant Valve Standards

Other inspections or tests can be performed or evaluation criteria applied when specified by the customer.

Notes

- Standard material is ASTM A216 Grade WCB.
- Standard trim is XU (13% Cr to hardface) which is suitable for a wide range of applications.
- Butt weld end dimensions shall be in accordance with ASME B16.25 Figure 2a or Figure 3a (without backing ring) for standard pipe schedules, unless otherwise specified in the purchase order. Butt weld ends shall not be produced from flanged end castings unless specifically authorized in writing by CRANE Energy Flow Solutions.

Class	Schedule
150/300	Standard
600	Extra Strong
900/1500	Schedule 160

- See "Technical Data" section for locations of bypasses, taps and drains.
- *Guide hard facing and machining on gate valves >24" is available upon request.

Class 150 • Outside Screw & Yoke • Flexible Wedge Disc

Figure 47

- Gate, Flanged

Figure 47½

- Gate, Butt Weld

Size Range:

- 2 through 24 inches
- (50 - 600 mm)

Pressure Temperature Rating

- Carbon Steel
- ASTM A216 Grade WCB
- 285 psi @ -20°F to 100°F
- (20 bar @ -28°C to 37°C)

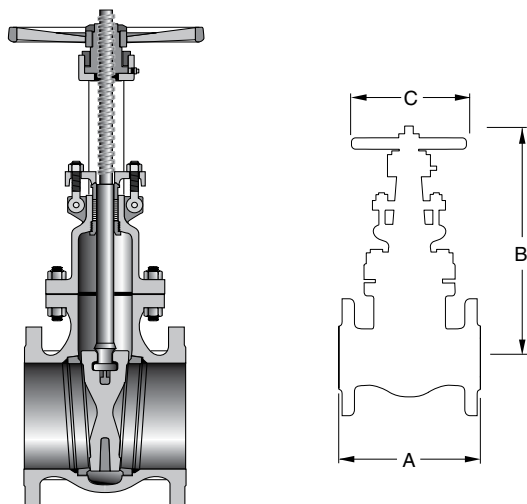

Material of Construction*

Description	Material
Body	ASTM A216 GR.WCB
Seat Ring	ASTM A105N + Alloy 6 Hardfaced
Disc	ASTM A216 GR.WCB + 13Cr Faced
Stem	ASTM A182 GR.F6a
Gasket	304SS + Graphite
Bonnet Bolts	ASTM A193 GR.B7
Bonnet Bolt Nuts	ASTM A194 GR.2H
Bonnet	ASTM A216 GR.WCB
Bonnet Bushing	ASTM A276 Type 410
Spacer Ring	ASTM A276 Type 410
Eye Bolt Pins	ASTM A29 GR.1045
Stem Packing	Braided Graphite & Die formed Graphite Ring
Gland	ASTM A276 Type 410
Gland Flange	ASTM A216 GR.WCB
Gland Eye Bolts	ASTM A193 GR.B7
Eye Bolt Nuts	ASTM A194 GR.2H
Grease Nipple	ASTM A29 GR.1020
Stem Nut	ASTM A439 GR.D-2
Retaining Nut	ASTM A29 GR.1045
Handwheel	ASTM A536 GR.60-40-18
Handwheel Nut	ASTM A29 GR.1045
Screw	ASTM A29 GR.1035
Nameplate	SS304
Screw	SS304

*Standard construction: WCB-Trim 8, other options are available.
Crane recommends the use of manual or powered gear assistance for sizes 10" and larger.

Industry Standards

Steel Valves	ASME B16.34
Face-to-Face/End-to-End	ASME B16.10
Flange Dimensions	ASME B16.5
Weld End	ASME B.16.25
Basic Design	API 600
Testing	API 598

Dimensions and Weights

Inches (millimeters) - pounds (kilograms)

Valves	2	2 ½	3	4	6	8	10	12	14	16 ⁽¹⁾	18 ⁽¹⁾	20 ⁽¹⁾	24 ⁽¹⁾
	(50)	(65)	(80)	(100)	(150)	(200)	(250)	(300)	(350)	(400)	(450)	(500)	(600)
A	7.00	7.50	8.00	9.00	10.50	11.50	13.00	14.00	15.00	16.00	17.00	18.00	20.00
(47)	(178)	(190)	(203)	(229)	(267)	(292)	(330)	(356)	(381)	(406)	(432)	(457)	(508)
A	8.50	9.50	11.12	12.00	15.88	16.50	18.00	19.75	22.50	24.00	26.00	28.00	32.00
(47½)	(216)	(241)	(282)	(305)	(403)	(419)	(457)	(502)	(572)	(610)	(660)	(711)	(813)
B	15.43	17.68	20.24	23.74	30.91	38.39	45.91	54.96	62.91	70.59	77.64	86.73	100.71
(Open)	(392)	(449)	(514)	(603)	(785)	(975)	(1166)	(1396)	(1598)	(1793)	(1972)	(2203)	(2558)
C	7.87	7.87	9.84	9.84	13.78	13.78	15.75	17.72	18.11	18.11	18.11	18.11	21.26
	(200)	(200)	(250)	(250)	(350)	(350)	(400)	(450)	(460)	(460)	(460)	(460)	(540)
Wt.	37.48	46.30	72.75	110.23	185.19	284.40	425.49	604.07	886.26	1117.74	1450.64	1781.34	2877.03
(47)	(17)	(21)	(33)	(50)	(84)	(129)	(193)	(274)	(402)	(507)	(658)	(808)	(1305)
Wt.	33.07	39.68	57.32	90.39	152.12	238.10	343.92	546.75	804.69	1062.63	1294.11	1657.88	3097.49
(47½)	(15)	(18)	(26)	(41)	(69)	(108)	(156)	(248)	(365)	(482)	(587)	(752)	(1405)

(1) Dimensions and weights shown with gear actuator.

Class 300 • Outside Screw & Yoke • Flexible Wedge Disc

Figure 33

- Gate, Flanged

Figure 33½

- Gate, Butt Weld

Size Range:

- 2 through 24 inches
- (50 - 600 mm)

Pressure Temperature Rating

- Carbon Steel
- ASTM A216 Grade WCB
- 740 psi @ -20°F to 100°F
- (51 bar @ -28°C to 37°C)

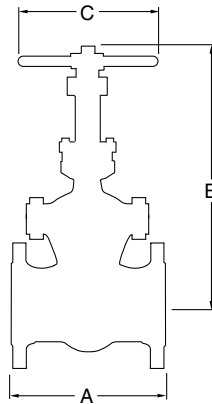
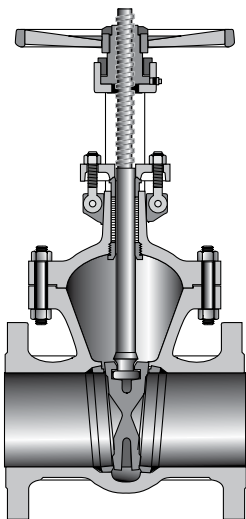

Material of Construction*

Description	Material
Body	ASTM A216 GR.WCB
Seat Ring	ASTM A105N + Alloy 6 Hardfaced
Disc	ASTM A216 GR.WCB + 13Cr Faced
Stem	ASTM A182 GR. F6a
Gasket	304SS + Graphite
Bonnet	ASTM A216 GR.WCB
Bonnet Bolts	ASTM A193 GR.B7
Bonnet Bolt Nuts	ASTM A194 GR.2H
Bonnet Bushing	ASTM A276 Type 410
Spacer Ring	ASTM A276 Type 410
Stem Packing	Braided Graphite & Die formed Graphite Ring
Gland	ASTM A276 Type 410
Gland Flange	ASTM A216 GR.WCB
Eye Bolt Pins	ASTM A29 GR.1045
Gland Eye Bolts	ASTM A193 GR.B7
Eye Bolt Nuts	ASTM A194 GR.2H
Grease Nipple	ASTM A29 GR.1020
Stem Nut	ASTM A439 GR.D-2
Retaining Nut	ASTM A29 GR.1045
Handwheel	ASTM A536 GR.60-40-18
Handwheel Nut	ASTM A29 GR.1045
Screw	ASTM A29 GR.1035
Nameplate	SS304
Screw	SS304

*Standard construction: WCB-Trim 8, other options are available.
Crane recommends the use of manual or powered gear assistance for sizes 8" and larger.

Industry Standards

Steel Valves	ASME B16.34
Face-to-Face/End-to-End	ASME B16.10
Flange Dimensions	ASME B16.5
Weld End	ASME B.16.25
Basic Design	API 600
Testing	API 598

Dimensions and Weights

Inches (millimeters) - pounds (kilograms)

Valves	2	2½	3	4	6	8	10	12	14 ⁽¹⁾	16 ⁽¹⁾	18 ⁽¹⁾	20 ⁽¹⁾	24 ⁽¹⁾
	(50)	(65)	(80)	(100)	(150)	(200)	(250)	(300)	(350)	(400)	(450)	(500)	(600)
A	8.50	9.50	11.12	12.00	15.88	16.50	18.00	19.75	30.00	33.00	36.00	39.00	45.00
(33)	(216)	(241)	(282)	(305)	(403)	(419)	(457)	(502)	(762)	(838)	(914)	(991)	(1143)
B	17.13	20.08	21.26	24.92	32.09	40.16	47.72	56.69	63.98	71.57	80.39	87.91	102.36
(Open)	(435)	(510)	(540)	(633)	(815)	(1020)	(1212)	(1440)	(1625)	(1818)	(2042)	(2233)	(2600)
C	7.87	7.87	9.84	9.84	13.78	15.75	17.72	19.69	18.11	18.11	21.26	21.26	24.02
	(200)	(200)	(250)	(250)	(350)	(400)	(450)	(500)	(460)	(460)	(540)	(540)	(610)
Wt.	59.52	(74.96)	114.64	163.14	321.87	485.02	617.29	1047.20	1530.01	2012.82	2722.71	3648.65	4828.12
(33)	(27)	(34)	(52)	(74)	(146)	(220)	(280)	(475)	(694)	(913)	(1235)	(1655)	(2190)
Wt.	37.48	57.32	105.82	143.30	249.12	361.56	758.39	1047.20	1245.61	1774.72	2332.49	3112.93	5079.45
(33½)	(17)	(26)	(48)	(65)	(113)	(164)	(344)	(475)	(565)	(805)	(1058)	(1412)	(2304)

(1) Dimensions and weights shown with gear actuator.
(2) Flanged end and butt-weld valves share same face-to-face dimensions.

Class 600 • Outside Screw & Yoke • Flexible Wedge Disc

Figure 76

- Gate, Flanged

Figure 76½

- Gate, Butt Weld

Size Range:

- 2 through 24 inches
- (50 - 600 mm)

Pressure Temperature Rating

- Carbon Steel
- ASTM A216 Grade WCB
- 1480 psi @ -20°F to 100°F
- (102 bar @ -28°C to 37°C)

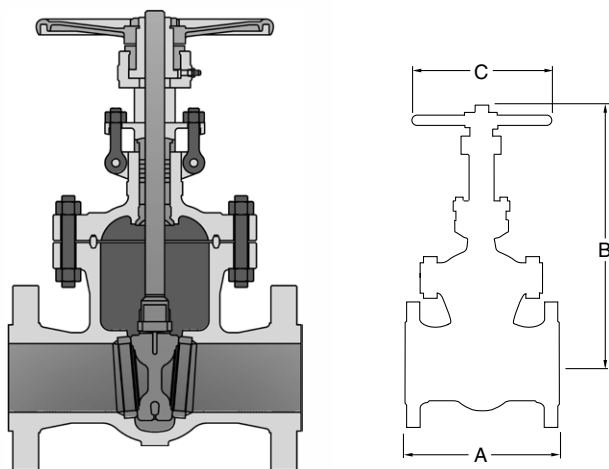

Dimensions and Weights

Inches (millimeters) - pounds (kilograms)

Valves	2	2½	3	4	6	8	10	12	14 ⁽¹⁾	16 ⁽¹⁾	18 ⁽¹⁾	20 ⁽¹⁾	24 ⁽¹⁾
	(50)	(65)	(80)	(100)	(150)	(200)	(250)	(300)	(350)	(400)	(450)	(500)	(600)
A	11.50	13.00	14.00	17.00	22.00	26.00	31.00	33.00	35.00	39.00	43.00	47.00	55.00
(76)	(292)	(330)	(356)	(432)	(559)	(660)	(787)	(838)	(889)	(991)	(1092)	(1194)	(1397)
B	16.81	20.55	22.68	26.10	35.87	44.13	50.67	57.80	69.41	79.72	81.57	90.24	107.17
(Open)	(427)	(522)	(576)	(663)	(911)	(1121)	(1287)	(1468)	(1763)	(2025)	(2072)	(2292)	(2722)
C	9.84	9.84	11.81	13.78	17.72	19.69	25.20	26.77	24.02	24.02	24.02	24.02	24.02
	(250)	(250)	(300)	(350)	(450)	(500)	(640)	(680)	(610)	(610)	(610)	(610)	(610)
Wt.	72.75	127.87	158.73	268.96	568.79	1031.76	1563.08	2072.35	2524.29	3417.17	4563.57	6558.75	9374.06
(76)	(33)	(58)	(72)	(122)	(258)	(468)	(709)	(940)	(1145)	(1550)	(2070)	(2975)	(4252)
Wt.	61.73	92.59	121.25	185.19	275.58	742.96	1208.13	1995.18	2147.30	2965.22	3814.00	5324.16	7528.79
(76½)	(28)	(42)	(55)	(84)	(125)	(337)	(548)	(905)	(974)	(1345)	(1730)	(2415)	(3415)

(1) Dimensions and weights shown with gear actuator.

(2) Flanged end and butt-weld valves share same face-to-face dimensions.

Material of Construction*

Description	Material
Body	ASTM A216 GR.WCB
Seat Ring	ASTM A105N + Alloy 6 Hardfaced
Disc	ASTM A216 GR.WCB + 13Cr Faced
Stem	ASTM A182 GR F6a
Gasket Ring	Soft Steel
Bonnet	ASTM A216 GR.WCB
Bonnet Bolts	ASTM A193 GR.B7
Bonnet Bolt Nuts	ASTM A194 GR.2H
Bonnet Bushing	ASTM A276 Type 410
Spacer Ring	ASTM A276 Type 410
Stem Packing	Braided Graphite & Die formed Graphite Ring
Gland	ASTM A276 Type 410
Gland Flange	ASTM A216 GR.WCB
Eye Bolt Pins	ASTM A29 GR.1045
Gland Eye Bolts	ASTM A193 GR.B7
Eye Bolt Nuts	ASTM A194 GR.2H
Grease Nipple	ASTM A29 GR.1020
Stem Nut	ASTM A439 GR.D-2
Retaining Nut	ASTM A29 GR.1045
Handwheel	ASTM A536 GR.60-40-18
Handwheel Nut	ASTM A29 GR.1045
Screw	ASTM A29 GR.1035
Bearing	ASTM A295 GR.52100
Yoke	ASTM A216 GR.WCB
Yoke Bolts	ASTM A193 GR.B7
Yoke Bolt Nuts	ASTM A194 GR.2H
Nameplate	SS304
Screw	SS304

*Standard construction: WCB-Trim 8, other options are available.

Crane recommends the use of manual or powered gear assistance for sizes 6" and larger.

Industry Standards

Steel Valves	ASME B16.34
Face-to-Face/End-to-End	ASME B16.10
Flange Dimensions	ASME B16.5
Weld End	ASME B.16.25
Basic Design	API 600
Testing	API 598

Class 900 • Outside Screw & Yoke • Flexible Wedge Disc

Figure 83

- Gate, Flanged

Figure 83½

- Gate, Butt Weld

Size Range:

- 2 through 24 inches
- (50 - 600 mm)

Pressure Temperature Rating

- Carbon Steel
- ASTM A216 Grade WCB
- 2220 psi @ -20°F to 100°F
- (153 bar @ -28°C to 37°C)

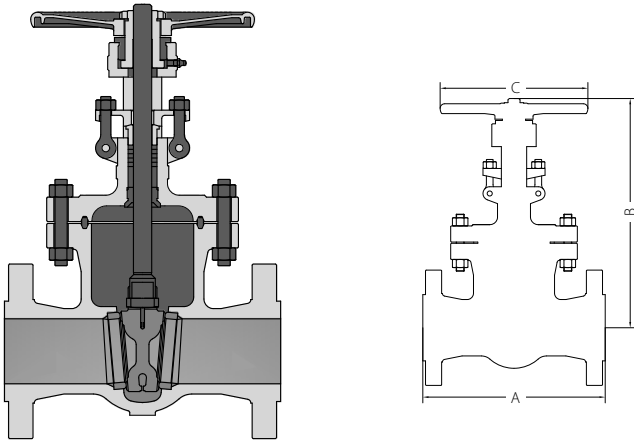

Dimensions and Weights

Inches (millimeters) - pounds (kilograms)

Valves	2	3	4	6	8	10	12	14 ⁽¹⁾	16 ⁽¹⁾	18 ⁽¹⁾	24 ⁽¹⁾
	(50)	(80)	(100)	(150)	(200)	(250)	(300)	(350)	(400)	(450)	(600)
A	14.50	15.00	18.00	24.00	29.00	33.00	38.00	40.50	44.50	48.00	61.00
(83)	(368)	(381)	(457)	(610)	(737)	(838)	(965)	(1029)	(1130)	(1219)	(1549)
B	19.88	22.95	26.02	37.01	43.43	52.60	58.66	68.74	75.98	90.16	110.55
(Open)	(505)	(583)	(661)	(940)	(1103)	(1336)	(1490)	(1746)	(1930)	(2290)	(2808)
C	11.81	13.78	15.75	22.05	25.20	26.77	29.92	24.02	24.02	31.89	31.89
	(300)	(350)	(400)	(560)	(640)	(680)	(760)	(610)	(610)	(810)	(810)
Wt.	163.14	220.46	427.70	820.12	1404.34	2347.92	3417.17	3487.71	5291.09	6172.94	13448.20
(83)	(74)	(100)	(194)	(372)	(637)	(1065)	(1550)	(1582)	(2400)	(2800)	(6100)
Wt.	119.05	154.32	242.51	584.22	1097.90	1785.74	2707.28	4429.09	5650.45	7275.25	13492.29
(83½)	(54)	(70)	(110)	(265)	(498)	(810)	(1228)	(2009)	(2563)	(3300)	(6120)

(1) Dimensions and weights shown with gear actuator.

(2) Flanged end and butt-weld valves share same face-to-face dimensions.

Material of Construction*

Description	Material
Body	ASTM A216 GR.WCB
Seat Ring	ASTM A105N +Alloy 6 Hardfaced
Disc	ASTM A216 GR.WCB + 13Cr Faced
Stem	ASTM A182 GR F6a
Gasket Ring	Soft steel
Bonnet	ASTM A216 GR.WCB
Bonnet Bolts	ASTM A193 GR.B7
Bonnet Bolt Nuts	ASTM A194 GR.2H
Bonnet Bushing	ASTM A276 Type 410
Spacer Ring	ASTM A276 Type 410
Stem Packing	Braided Graphite & Die formed Graphite Ring
Gland	ASTM A276 Type 410
Gland Flange	ASTM A216 GR.WCB
Eye Bolt Pins	ASTM A29 GR.1045
Gland Eye Bolts	ASTM A193 GR.B7
Eye Bolt Nuts	ASTM A194 GR.2H
Grease Nipple	ASTM A29 GR.1020
Stem Nut	ASTM A439 GR.D-2
Retaining Nut	ASTM A29 GR.1045
Handwheel	ASTM A536 GR.60-40-18
Handwheel Nut	ASTM A29 GR.1045
Screw	ASTM A29 GR.1035
Bearing	ASTM A295 GR.52100
Yoke	ASTM A216 GR.WCB
Yoke Bolts	ASTM A193 GR.B7
Yoke Bolt Nuts	ASTM A194 GR.2H
Nameplate	SS304
Screw	SS304

*Standard construction: WCB-Trim 8, other options are available.

Crane recommends the use of manual or powered gear assistance for sizes 6" and larger.

Industry Standards

Steel Valves	ASME B16.34
Face-to-Face/End-to-End	ASME B16.10
Flange Dimensions	ASME B16.5
Weld End	ASME B.16.25
Basic Design	API 600
Testing	API 598

Class 1500 • Outside Screw & Yoke • Flexible Wedge Disc

Figure 87

- Gate, Flanged

Figure 87½

- Gate, Butt Weld

Size Range:

- 2 through 16 inches
- (50 - 400 mm)

Pressure Temperature Rating

- Carbon Steel
- ASTM A216 Grade WCB
- 3705 psi @ -20°F to 100°F
- (255 bar @ -28°C to 37°C)

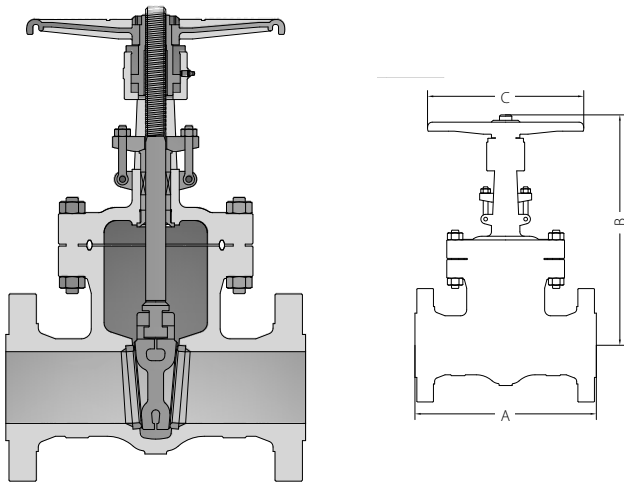

Dimensions and Weights

Inches (millimeters) - pounds (kilograms)

Valves	2	3	4	6	8 ⁽¹⁾	10 ⁽¹⁾	12 ⁽¹⁾	14 ⁽¹⁾	16 ⁽¹⁾
	(50)	(80)	(100)	(150)	(200)	(250)	(300)	(350)	(400)
A	14.50	18.50	21.50	27.75	32.75	39.00	44.50	49.50	54.50
(87)	(368)	(470)	(546)	(705)	(832)	(991)	(1130)	(1257)	(1384)
B	19.88	24.72	28.94	38.31	45.94	56.69	62.01	74.21	83.70
(Open)	(505)	(628)	(735)	(973)	(1167)	(1440)	(1575)	(1885)	(2126)
C	11.81	15.75	19.69	25.20	21.26	24.02	24.02	31.89	31.89
	(300)	(400)	(500)	(640)	(540)	(610)	(610)	(810)	(810)
Wt.	171.96	370.38	507.06	1203.72	1563.08	2072.35	4982.45	9038.95	13668.66
(87)	(78)	(168)	(230)	(546)	(709)	(940)	(2260)	(4100)	(6200)
Wt.	119.05	284.40	434.31	789.25	1677.72	3615.58	4287.99	7054.79	11684.50
(87½)	(54)	(129)	(197)	(358)	(761)	(1640)	(1945)	(3200)	(5300)

(1) Dimensions and weights shown with gear actuator.

(2) Flanged end and butt-weld valves share same face-to-face dimensions.

Material of Construction*

Description	Material
Body	ASTM A216 GR.WCB
Seat Ring	ASTM A105N + Alloy 6 Hardfaced
Disc	ASTM A216 GR.WCB + 13Cr Faced
Stem	ASTM A182 GR F6a
Gasket Ring	Soft steel
Bonnet	ASTM A216 GR.WCB
Bonnet Bolts	ASTM A193 GR.B7
Bonnet Bolt Nuts	ASTM A194 GR.2H
Bonnet Bushing	ASTM A276 Type 410
Spacer Ring	ASTM A276 Type 410
Stem Packing	Braided Graphite & Die formed Graphite Ring
Gland	ASTM A276 Type 410
Gland Flange	ASTM A216 GR.WCB
Eye Bolt Pins	ASTM A29 GR.1045
Gland Eye Bolts	ASTM A193 GR.B7
Eye Bolt Nuts	ASTM A194 GR.2H
Bearing	ASTM A295 GR.52100
Grease Nipple	ASTM A29 GR.1020
Stem Nut	ASTM A439 GR.D-2
Retaining Nut	ASTM A29 GR.1045
Handwheel	ASTM A536 GR.60-40-18
Handwheel Nut	ASTM A29 GR.1045
Screw	ASTM A29 GR.1035
Yoke	ASTM A216 GR.WCB
Yoke Bolts	ASTM A193 GR.B7
Yoke Bolt Nuts	ASTM A194 GR.2H
Nameplate	SS304
Screw	SS304

*Standard construction: WCB-Trim 8, other options are available. Crane recommends the use of manual or powered gear assistance for sizes 4" and larger.

Industry Standards

Steel Valves	ASME B16.34
Face-to-Face/End-to-End	ASME B16.10
Flange Dimensions	ASME B16.5
Weld End	ASME B.16.25
Basic Design	API 600
Testing	API 598

NACE Trim Specialty Steel Valves

For servicing sour environments of Hydrogen Sulfide (H₂S) bearing hydrocarbons, Crane offers NACE valves made of component materials specially heat-treated and hardness-controlled in compliance with NACE standard MR0103. Typical NACE material configurations are shown below for Crane cast steel gate valves.

- A** Body & Bonnet – Most NACE requirements for heat treatment and maximum hardness of 22 HRC. Standard material is ASTM A216 Grade WCB.
- B** Bolting – ASTM A193 Grade B7M bolts and ASTM A194 Grade 2HM nuts meet both NACE Classes I and II.
- C** Stem – Offering superior resistance to stress corrosion cracking, standard NACE stem is type 316 stainless steel in conformance with NACE hardness and heat treatment requirements.
- D** Disc – Standard disc is one piece flexible wedge with overlay hardface of ASTM A351 Grade CF8M, type 316 stainless steel in conformance with NACE hardness and heat treatment requirements.

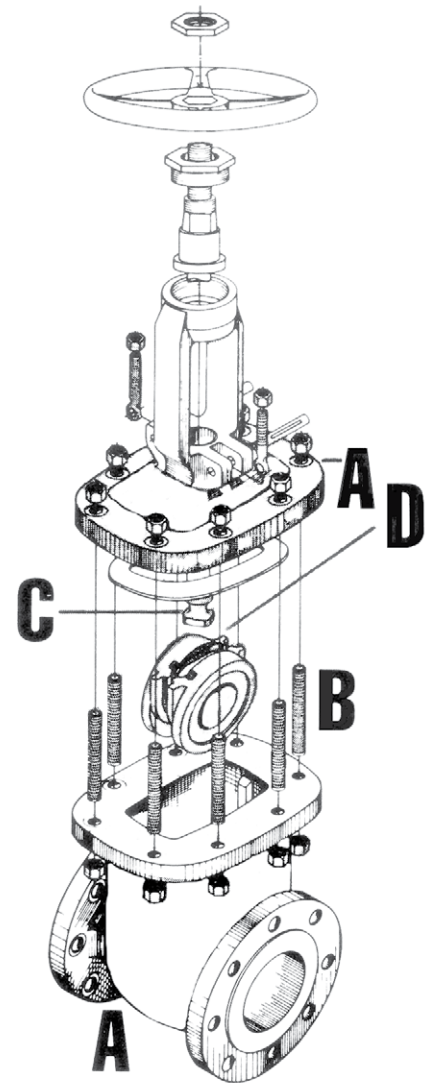

Valve Parts	API and Hardness	LF Trim NACE	LUF Trim NACE
Body/Bonnet	ASTM A216 Grade WCB	ASTM A216 Grade WCB; ≤22HRC Base Metal with trim overlay of	ASTM A216 Grade WCB; ≤22HRC Base Metal with trim overlay of
Disc – Solid Metal	ASTM A217 Grade CA15; 250 min.	ASTM A351 Grade CF8M; ≤22HRC	ASTM A351 Grade CF8M; ≤22HRC
Seat Ring	CoCr overlayed; Overlay ≥350 HB	316L Overlayed; Base Metal ≤22 HRC	CoCr Overlayed; Base Metal ≤22 HRC
Gland	Steel Zinc Plated	Steel Zinc Plated; Base Metal ≤22 HRC	Steel Zinc Plated; Base Metal ≤22 HRC
Stem	13Cr; 200–275 HB	ASTM A182 Grade F316; ≤22HRC	ASTM A182 Grade F316; ≤22HRC
Backseat Bushing	13Cr; 250 HB min.	ASTM 479 Grade T316; ≤22 HRC	ASTM 479 Grade T316; ≤22HRC
Body/Bonnet Studs	ASTM A193 Grade 2H	ASTM A193 Grade B7M	ASTM A193 Grade B7M
Body/Bonnet Nuts	ASTM A194 Grade 2H	ASTM A194 Grade 2HM	ASTM A194 Grade 2HM

Overview Class 150, 300, 600, 900 & 1500 Globe Valves

Features

Welded-in Seat Ring

- Seat ring is seal welded to eliminate leak path.

Basic Standards

These valves comply with the applicable requirements of the following standards:

- API 623
- API 622
- API 624
- API 598
- ASME B16.34
- ASME B16.25
- ASME B16.10
- ASME B16.5

Notes

- Standard material is ASTM A216 Grade WCB.
- Standard trim is XU (13% Cr to hardface) which is suitable for a wide range of applications.
- Butt weld end dimensions shall be in accordance with ASME B16.25 Figure 2a or Figure 3a (without backing ring) for standard pipe schedules, unless otherwise specified in the purchase order. Butt weld ends shall not be produced from flanged end castings unless specifically authorized in writing by CRANE Energy Flow Solutions.

Class	Schedule
150/300	Standard
600	Extra Strong
900/1500	Schedule 160

- See "Technical Data" section for locations of bypasses, taps and drains.

Class 150 • Outside Screw & Yoke • Bolted Bonnet

Figure 143

- Globe, Flanged

Figure 143½

- Globe, Butt Weld

Size Range:

- 2 through 12 inches
- (50 - 300 mm)

Pressure Temperature Rating

- Carbon Steel
- ASTM A216 Grade WCB
- 285 psi @ -20°F to 100°F
- (20 bar @ -28°C to 37°C)

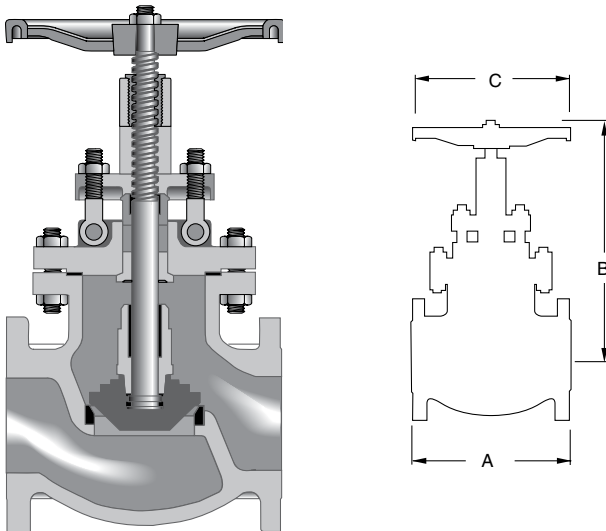

Material of Construction*

Description	Material
Body	ASTM A216 GR.WCB
Seat Ring	ASTM A105N+ Alloy 6 Hardfaced
Disc	ASTM A105N + 13Cr Faced
Disc Thrust Plate	ASTM A276 Type 420
Disc Nut	ASTM A276 Type 410
Stem	ASTM A182 GR F6a
Bonnet Bolt Nuts	ASTM A194 GR.2H
Bonnet Bolts	ASTM A193 GR.B7
Gasket	304SS + Graphite
Bonnet	ASTM A216 GR.WCB
Bonnet Bushing	ASTM A276 Type 410
Packing Spacer	ASTM A276 Type 410
Stem Packing	Braided Graphite & Die formed Graphite Ring
Eye Bolt Pins	ASTM A29 GR.1045
Gland	ASTM A276 Type 410
Gland Flange	ASTM A216 GR.WCB
Gland Eye Bolts	ASTM A193 GR.B7
Eye Bolt Nuts	ASTM A194 GR.2H
Stem Nut	ASTM A439 GR.D-2
Screw	ASTM A29 GR.1035
Handwheel	ASTM A536 GR.60-40-18
Handwheel Nut	ASTM A29 GR.1045
Washer	ASTM A29 GR.1045
Nameplate	SS304

*Standard construction: WCB-Trim 8, other options are available.
Crane recommends the use of manual or powered gear assistance for sizes 6" and larger.

Industry Standards

Steel Valves	ASME B16.34
Face-to-Face/End-to-End	ASME B16.10
Flange Dimensions	ASME B16.5
Weld End	ASME B.16.25
Testing	API 598
Basic Design	API 623

Dimensions and Weights

Inches (millimeters) - pounds (kilograms)

Valves	2	2 ½	3	4	6	8	10	12	14 ⁽¹⁾	16 ⁽¹⁾
	(50)	(65)	(80)	(100)	(150)	(200)	(250)	(300)	(350)	(400)
A	8.00	8.50	9.50	11.50	16.00	19.50	24.50	27.50	31.00	36.00
(143)	(203)	(216)	(241)	(292)	(406)	(495)	(622)	(698)	(787)	(914)
B	13.90	16.00	15.79	18.23	21.10	24.45	27.99	35.94	44.13	46.61
(Open)	(353)	(406)	(401)	(463)	(536)	(621)	(711)	(913)	(1121)	(1184)
C	7.87	8.00	9.84	11.81	13.78	17.72	17.72	25.20	24.02	24.02
	(200)	(203)	(250)	(300)	(350)	(450)	(450)	(640)	(610)	(610)
Wt.	44.09	70.00	88.18	132.28	224.87	352.74	601.86	928.15	1360.25	1543.24
(143)	(20)	(31)	(40)	(60)	(102)	(160)	(273)	(421)	(617)	(700)
Wt.	37.48	44.09	77.16	103.62	189.60	304.24	482.81	798.07	1082.47	1433.00
(143½)	(17)	(20)	(35)	(47)	(86)	(138)	(219)	(362)	(491)	(650)

(1) Dimensions and weights shown with gear actuator.
 (2) Flanged end and butt-weld valves share same face-to-face dimensions.
 (3) Hammer Blow hand wheels is a standard offering on sizes 8"-16"

Class 300 • Outside Screw & Yoke • Bolted Bonnet

Figure 151

- Globe, Flanged

Figure 151½

- Globe, Butt Weld

Size Range:

- 2 through 12 inches
- (50 - 300 mm)

Pressure Temperature Rating

- Carbon Steel
- ASTM A216 Grade WCB
- 740 psi @ -20°F to 100°F
- (51 bar @ -28°C to 37°C)

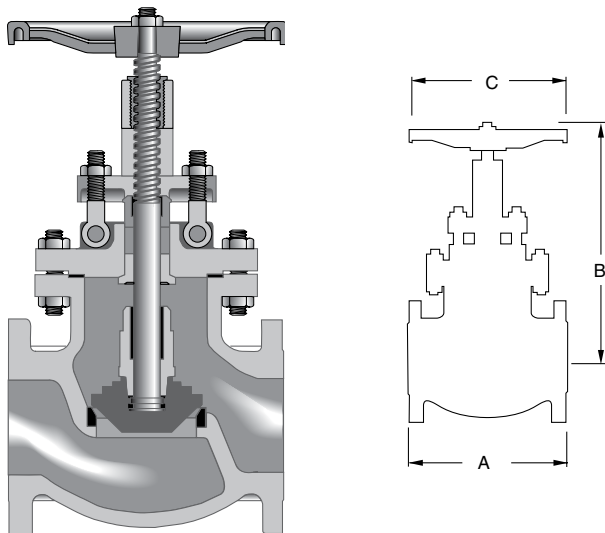

Material of Construction*

Description	Material
Body	ASTM A216 GR.WCB
Seat Ring	ASTM A105N+ Alloy 6 Hardfaced
Disc	ASTM A105N + 13Cr Faced
Disc Thrust Plate	ASTM A276 Type 420
Disc Nut	ASTM A276 Type 410
Stem	ASTM A182 GR.F6a
Gasket	304SS + Graphite
Bonnet	ASTM A216 GR.WCB
Bonnet Bolt Nuts	ASTM A194 GR.2H
Bonnet Bolts	ASTM A193 GR.B7
Bonnet Bushing	ASTM A276 Type 410
Packing Spacer	ASTM A276 Type 410
Stem Packing	Braided Graphite & Die formed Graphite Ring
Eye Bolt Pins	ASTM A29 GR.1045
Gland	ASTM A276 Type 410
Gland Flange	ASTM A216 GR.WCB
Gland Eye Bolts	ASTM A193 GR.B7
Eye Bolt Nuts	ASTM A194 GR.2H
Stem Nut	ASTM A439 GR.D-2
Screw	ASTM A29 GR.1035
Handwheel	ASTM A536 GR.60-40-18
Handwheel Nut	ASTM A29 GR.1045
Washer	ASTM A29 GR.1045
Nameplate	SS304

*Standard construction: WCB-Trim 8, other options are available.
Crane recommends the use of manual or powered gear assistance for sizes 6" and larger.

Industry Standards

Steel Valves	ASME B16.34
Face-to-Face/End-to-End	ASME B16.10
Flange Dimensions	ASME B16.5
Weld End	ASME B.16.25
Testing	API 598
Basic Design	API 623

Dimensions and Weights

Inches (millimeters) - pounds (kilograms)

Valves	2	2 ½	3	4	6	8	10	12	14 ⁽¹⁾	16 ⁽¹⁾
	(50)	(65)	(80)	(100)	(150)	(200)	(250)	(300)	(350)	(400)
A	10.50	11.50	12.50	14.00	17.50	22.00	24.50	28.00	33.00	34.00
(151)	(267)	(292)	(318)	(356)	(444)	(559)	(622)	(711)	(838)	(864)
B	14.33	18.00	16.89	20.55	23.74	33.82	35.63	39.92	54.76	61.10
(Open)	(364)	(457)	(429)	(522)	(603)	(859)	(905)	(1014)	(1391)	(1552)
C	7.87	10.00	9.84	13.78	17.72	17.72	22.05	25.20	24.02	31.89
	(200)	(254)	(250)	(350)	(450)	(450)	(560)	(640)	(610)	(810)
Wt.	57.32	99.00	110.23	171.96	339.51	648.16	703.27	888.46	1785.74	2127.46
(151)	(26)	(44)	(50)	(78)	154	(294)	(319)	(403)	(810)	(965)
Wt.	46.30	63.93	83.78	130.07	302.03	522.50	952.40	1393.32	2149.51	3196.70
(151½)	(21)	(29)	(38)	(59)	(137)	(237)	(432)	(632)	(975)	(1450)

(1) Dimensions and weights shown with gear actuator.
 (2) Flanged end and butt-weld valves share same face-to-face dimensions.
 (3) Hammer Blow hand wheels is a standard offering on sizes 8"-14"

Class 600 • Outside Screw & Yoke • Bolted Bonnet

Figure 171

- Globe, Flanged

Figure 171½

- Globe, Butt Weld

Size Range:

- 2 through 16 inches
- (50 - 400 mm)

Pressure Temperature Rating

- Carbon Steel
- ASTM A216 Grade WCB
- 1480 psi @ -20°F to 100°F
- (102 bar @ -28°C to 37°C)

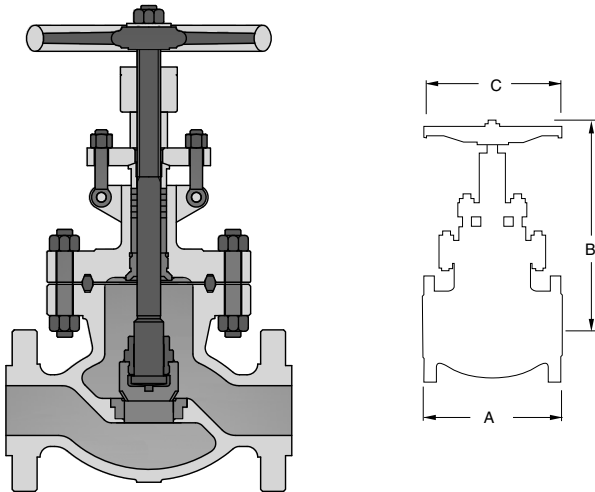

Material of Construction*

Description	Material
Body	ASTM A216 GR.WCB
Seat Ring	ASTM A105N+Alloy 6 Hardfaced
Disc	ASTM A105N + 13Cr Faced
Disc Thrust Plate	ASTM A276 Type 420
Disc Nut	ASTM A276 Type 410
Stem	ASTM A182 GR F6a
Gasket	304SS + Graphite
Bonnet	ASTM A216 GR.WCB
Bonnet Bolt Nuts	ASTM A194 GR.2H
Bonnet Bolts	ASTM A193 GR.B7
Bonnet Bushing	ASTM A276 Type 410
Packing Spacer	ASTM A276 Type 410
Stem Packing	Braided Graphite & Die formed Graphite Ring
Eye Bolt Pins	ASTM A29 GR.1045
Gland	ASTM A276 Type 410
Gland Flange	ASTM A216 GR.WCB
Gland Eye Bolts	ASTM A193 GR.B7
Eye Bolt Nuts	ASTM A194 GR.2H
Stem Nut	ASTM A439 GR.D-2
Screw	ASTM A29 GR.1035
Handwheel	ASTM A536 GR.60-40-18
Handwheel Nut	ASTM A29 GR.1045
Washer	ASTM A29 GR.1045
Nameplate	SS304

*Standard construction: WCB-Trim 8, other options are available.
Crane recommends the use of manual or powered gear assistance for sizes 4" and larger.

Industry Standards

Steel Valves	ASME B16.34
Face-to-Face/End-to-End	ASME B16.10
Flange Dimensions	ASME B16.5
Weld End	ASME B.16.25
Testing	API 598
Basic Design	API 623

Dimensions and Weights

Inches (millimeters) - pounds (kilograms)

Valves	2	2 ½	3	4	6	8	10	12	14 ⁽¹⁾	16 ⁽¹⁾
	(50)	(65)	(80)	(100)	(150)	(200)	(250)	(300)	(350)	(400)
A	11.50	13.00	14.00	17.00	22.00	26.00	31.00	33.00	35.00	39.00
(171)	(292)	(330)	(356)	(432)	(559)	(660)	(787)	(838)	(889)	(991)
B	18.35	21.00	22.05	26.50	31.50	36.93	39.13	43.39	55.12	59.84
(Open)	(466)	(528)	(560)	(673)	(800)	(938)	(994)	(1102)	(1400)	(1520)
C	9.84	10.00	13.78	17.72	19.69	25.20	28.35	28.35	31.89	39.37
	(250)	(250)	(350)	(450)	(500)	(640)	(720)	(720)	(810)	(1000)
Wt.	105.82	154.00	185.19	295.42	551.16	837.76	1496.94	2495.63	3571.49	3747.86
(171)	(48)	(70)	(84)	(134)	(250)	(380)	(679)	(1132)	(1620)	(1700)
Wt.	66.14	88.18	127.87	291.01	500.45	1014.13	1607.17	2336.90	2932.15	3858.09
(171½)	(30)	(40)	(58)	(132)	(227)	(460)	(729)	(1060)	(1330)	(1750)

(1) Dimensions and weights shown with gear actuator.
(2) Flanged end and butt-weld valves share same face-to-face dimensions.
(3) Hammer Blow hand wheels is a standard offering on sizes 6"-12"

Class 900 • Outside Screw & Yoke • Bolted Bonnet

Figure 183

- Globe, Flanged

Figure 183½

- Globe, Butt Weld

Size Range:

- 2 through 12 inches
- (50 - 300 mm)

Pressure Temperature Rating

- Carbon Steel
- ASTM A216 Grade WCB
- 2220 psi @ -20°F to 100°F
- (153 bar @ -28°C to 37°C)

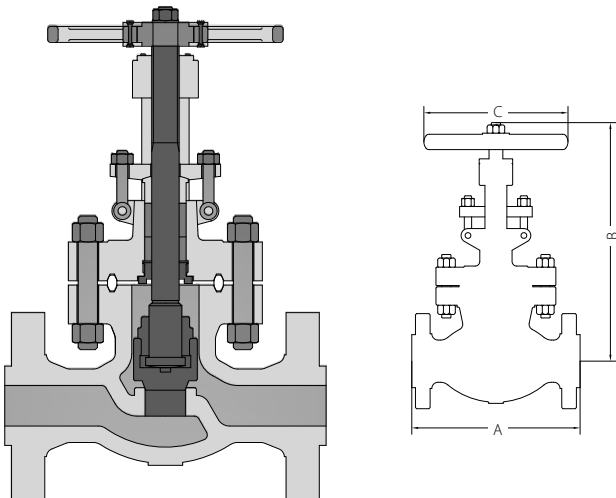

Material of Construction*

Description	Material
Body	ASTM A216 GR.WCB
Integral Seat	STL Overlay
Disc	ASTM A105N + 13Cr Faced
Disc Thrust Plate	ASTM A276 Type 420
Disc Nut	ASTM A276 Type 410
Stem	ASTM A182 GR F6a
Gasket Ring	Soft Steel
Bonnet	ASTM A216 GR.WCB
Bonnet Bolt Nuts	ASTM A194 GR.2H
Bonnet Bolts	ASTM A193 GR.B7
Bonnet Bushing	ASTM A276 Type 410
Packing Spacer	ASTM A276 Type 410
Stem Packing	Braided Graphite & Die formed Graphite Ring
Eye Bolt Pins	ASTM A29 GR.1045
Gland	ASTM A276 Type 410
Gland Flange	ASTM A216 GR.WCB
Gland Eye Bolts	ASTM A193 GR.B7
Eye Bolt Nuts	ASTM A194 GR.2H
Stem Nut	ASTM A439 GR.D-2
Screw	ASTM A29 GR.1035
Handwheel	ASTM A536 GR.60-40-18
Screw	ASTM A29 GR.1035
Baffle	ASTM A29 GR.1045
Shock block	ASTM A29 GR.1045
Handwheel Nut	ASTM A29 GR.1045
Washer	ASTM A29 GR.1045
Nameplate	SS304

*Standard construction: WCB-Trim 8, other options are available.
Crane recommends the use of manual or powered gear assistance for sizes 4" and larger.

Industry Standards

Steel Valves	ASME B16.34
Face-to-Face/End-to-End	ASME B16.10
Flange Dimensions	ASME B16.5
Weld End	ASME B.16.25
Testing	API 598
Basic Design	API 623

Dimensions and Weights

Inches (millimeters) - pounds (kilograms)

Valves	2 (50)	3 (80)	4 (100)	6 (150)	8 (200)	10 ⁽¹⁾ (250)	12 ⁽¹⁾ (300)
A	15.50	15.00	18.00	24.00	29.00	33.00	38.00
(183)	(368)	(381)	(457)	(610)	(737)	(838)	(965)
B	18.35	22.91	28.35	33.98	36.10	50.35	58.66
(Open)	(466)	(582)	(720)	(863)	(917)	(1279)	(1490)
C	13.78	13.78	17.72	22.05	28.35	31.89	31.89
	(350)	(350)	(450)	(560)	(720)	(810)	(810)
Wt.	171.96	275.58	462.97	824.53	1653.47	2358.95	4232.88
(183)	(78)	(125)	(210)	(374)	(750)	(1070)	(1920)
Wt.	165.35	246.92	348.33	793.66	1316.16	1962.11	3725.81
(183½)	(75)	(112)	(158)	(360)	(597)	(890)	(1690)

(1) Dimensions and weights shown with gear actuator.
(2) Flanged end and butt-weld valves share same face-to-face dimensions.
(3) Hammer Blow hand wheels is a standard offering on sizes 2"-10"

Class 1500 • Outside Screw & Yoke • Bolted Bonnet

Figure 189

- Globe, Flanged

Figure 189½

- Globe, Butt Weld

Size Range:

- 2 through 8 inches
- (50 - 200 mm)

Pressure Temperature Rating

- Carbon Steel
- ASTM A216 Grade WCB
- 3705 psi @ -20°F to 100°F
- (255 bar @ -28°C to 37°C)

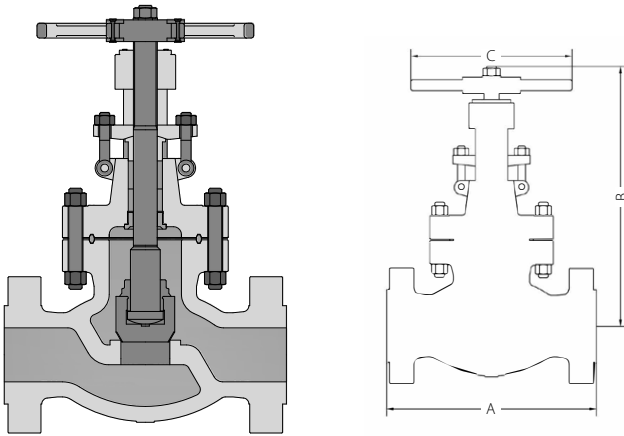

Material of Construction*

Description	Material
Body	ASTM A216 GR.WCB
Integral Seat	STL Overlay
Disc	ASTM A105N + 13Cr Faced
Disc Thrust Plate	ASTM A276 Type 420
Disc Nut	ASTM A276 Type 410
Stem	ASTM A182 GR.F6a
Gasket Ring	Soft Steel
Bonnet	ASTM A216 GR.WCB
Bonnet Bolt Nuts	ASTM A194 GR.2H
Bonnet Bolts	ASTM A193 GR.B7
Bonnet Bushing	ASTM A276 Type 410
Packing Spacer	ASTM A276 Type 410
Stem Packing	Braided Graphite & Die formed Graphite Ring
Eye Bolt Pins	ASTM A29 GR.1045
Gland	ASTM A276 Type 410
Gland Flange	ASTM A216 GR.WCB
Gland Eye Bolts	ASTM A193 GR.B7
Eye Bolt Nuts	ASTM A194 GR.2H
Stem Nut	ASTM A439 GR.D-2
Screw	ASTM A29 GR.1035
Handwheel	ASTM A536 GR.60-40-18
Screw	ASTM A29 GR.1035
Baffle	ASTM A29 GR.1045
Shock block	ASTM A29 GR.1045
Handwheel Nut	ASTM A29 GR.1045
Washer	ASTM A29 GR.1045
Nameplate	SS304

*Standard construction: WCB-Trim 8, other options are available.
Crane recommends the use of manual or powered gear assistance for sizes 3" and larger.

Industry Standards

Steel Valves	ASME B16.34
Face-to-Face/End-to-End	ASME B16.10
Flange Dimensions	ASME B16.5
Weld End	ASME B.16.25
Testing	API 598
Basic Design	API 623

Dimensions and Weights

Inches (millimeters) - pounds (kilograms)

Valves	2	3	4 ⁽¹⁾	6 ⁽¹⁾	8 ⁽¹⁾
	(50)	(80)	(100)	(150)	(200)
A	14.50	18.50	21.50	27.75	32.75
(189)	(368)	(470)	(546)	(705)	(832)
B	18.35	28.35	36.61	44.25	69.65
(Open)	(466)	(720)	(930)	(1124)	(1769)
C	13.78	17.72	21.26	24.02	31.89
	(350)	(450)	(540)	(610)	(810)
Wt.	209.44	399.04	771.62	1234.59	2182.58
(189)	(95)	(181)	(350)	(560)	(990)
Wt.	176.37	284.40	659.18	1018.54	5004.49
(189½)	(80)	(129)	(299)	(462)	(2270)

(1) Dimensions and weights shown with gear actuator.
(2) Flanged end and butt-weld valves share same face-to-face dimensions.
(3) Hammer Blow hand wheels is a standard offering on sizes 2"-6"

Overview Class 150, 300, 600, 900 & 1500 Check Valves

Features

Disc Type

- For class 600 valves, a ring joint bonnet gasket assures positive seal against leakage and accurate alignment of moving parts

Welded-in Seat Ring

- Seat ring is seal welded to eliminate leak path.

Basic Standards

These valves comply with the applicable requirements of the following standards:

- API 594
- API 598
- ASME B16.34
- ASME B16.25
- ASME B16.10
- ASME B16.5

Notes

- Standard material is ASTM A216 Grade WCB.
- Standard trim is XU (13% Cr to hardface) which is suitable for a wide range of applications.
- Butt weld end dimensions shall be in accordance with ASME B16.25 Figure 2a or Figure 3a (without backing ring) for standard pipe schedules, unless otherwise specified in the purchase order. Butt weld ends shall not be produced from flanged end castings unless specifically authorized in writing by CRANE Energy Flow Solutions.

Class	Schedule
150/300	Standard
600	Extra Strong
900/1500	Schedule 160

- See "Technical Data" section for locations of bypasses, taps and drains.

Class 150 • Bolted Cap

Figure 147

- Swing Check, Flanged

Figure 147½

- Swing Check, Butt Weld

Size Range:

- 2 through 24 inches
- (50 - 600 mm)

Pressure Temperature Rating

- Carbon Steel
- ASTM A216 Grade WCB
- 285 psi @ -20°F to 100°F
- (20 bar @ -28°C to 37°C)

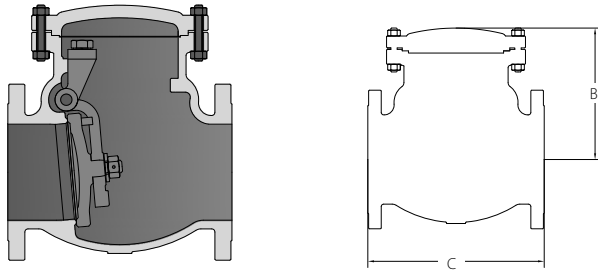

Material of Construction*

Description	Material
Body	ASTM A216 GR.WCB
Seat Ring	ASTM A105N +Alloy 6 Hardfaced
Disc	ASTM A216 GR.WCB + 13Cr Faced
Disc Washer	ASTM A29 GR.1020
Disc Nut Pin	ASTM A276 Type 410
Disc Nut	ASTM A29 GR.1045
Hinge	ASTM A216 GR.WCB
Hinge Pin	ASTM A182 GR.F6a
Bearing Bracket	ASTM A216 GR.WCB
Spring Washer	ASTM A29 GR.1045
Hex Bolt	ASTM A29 GR.1035
Gasket	304SS + Graphite
Cover Bolt	ASTM A193 GR.B7
Cover Bolt Nut	ASTM A194 GR.2H
Cover	ASTM A216 GR.WCB
Eye Bolt	ASTM A181
Nameplate	SS304
Screw	SS304

*Standard construction: WCB-Trim 8, other options are available.

Industry Standards

Steel Valves	ASME B16.34
Face-to-Face/End-to-End	ASME B16.10
Flange Dimensions	ASME B16.5
Weld End	ASME B.16.25
Testing	API 598
Basic Design	API 594

Dimensions and Weights

Inches (millimeters) - pounds (kilograms)

Valves	2	2½	3	4	6	8	10	12	14	16	18	20	24
	(50)	(65)	(80)	(100)	(150)	(200)	(250)	(300)	(350)	(400)	(450)	(500)	(600)
A	8.00	8.50	9.50	11.50	16.00	19.50	24.50	27.50	31.00	36.00	38.50	38.50	51.00
(147)	(203)	(216)	(241)	(292)	(406)	(495)	(622)	(698)	(787)	(914)	(978)	(978)	(1295)
B	6.02	7.01	7.13	8.39	12.17	14.45	17.01	19.76	22.09	23.31	27.64	26.50	32.56
(Open)	(153)	(178)	(181)	(213)	(309)	(367)	(432)	(502)	(561)	(592)	(702)	(673)	(827)
Wt.	48.50	55.12	66.14	110.23	171.96	308.65	458.56	784.85	981.06	1322.77	2259.74	2303.83	2601.45
(147)	(22)	(25)	(30)	(50)	(78)	(140)	(208)	(356)	(445)	(600)	(1025)	(1045)	(1180)
Wt.	22.05	26.46	37.48	63.93	125.66	211.64	315.26	500.45	648.16	1031.76	1216.95	1664.49	1832.04
(147½)	(10)	(12)	(17)	(29)	(57)	(96)	(143)	(227)	(294)	(468)	(552)	(755)	(831)

(2) Flanged end and butt-weld valves share same face-to-face dimensions.

Class 300 • Bolted Cap

Figure 159

- Swing Check, Flanged

Figure 159½

- Swing Check, Butt Weld

Size Range:

- 2 through 24 inches
- (50 - 600 mm)

Pressure Temperature Rating

- Carbon Steel
- ASTM A216 Grade WCB
- 740 psi @ -20°F to 100°F
- (51 bar @ -28°C to 37°C)

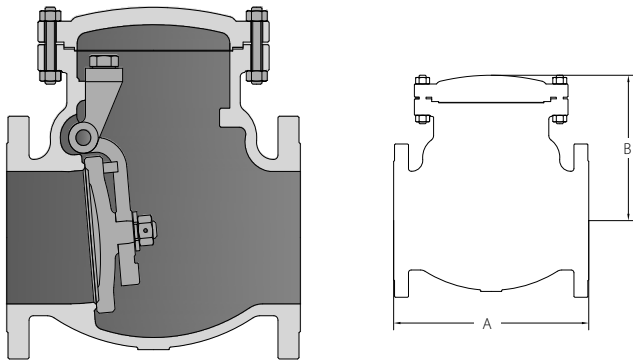

Material of Construction*

Description	Material
Body	ASTM A216 GR.WCB
Seat Ring	ASTM A105N + Alloy 6 Hardfaced
Disc	ASTM A216 GR.WCB + 13Cr Faced
Disc Washer	ASTM A29 GR.1020
Disc Nut Pin	ASTM A276 Type 410
Disc Nut	ASTM A29 GR.1045
Hinge	ASTM A216 GR.WCB
Hinge Pin	ASTM A182 GR.F6a
Bearing Bracket	ASTM A216 GR.WCB
Spring Washer	ASTM A29 GR.1045
Hex Bolt	ASTM A29 GR.1035
Gasket	304SS + Graphite
Cover Bolt	ASTM A193 GR.B7
Cover Bolt Nut	ASTM A194 GR.2H
Cover	ASTM A216 GR.WCB
Eye Bolt	ASTM A181
Nameplate	SS304
Screw	SS304

*Standard construction: WCB-Trim 8, other options are available.

Industry Standards

Steel Valves	ASME B16.34
Face-to-Face/End-to-End	ASME B16.10
Flange Dimensions	ASME B16.5
Weld End	ASME B.16.25
Testing	API 598
Basic Design	API 594

Dimensions and Weights

Inches (millimeters) - pounds (kilograms)

Valves	2	2½	3	4	6	8	10	12	14	16	18	20	24
	(50)	(65)	(80)	(100)	(150)	(200)	(250)	(300)	(350)	(400)	(450)	(500)	(600)
A	10.50	11.50	12.50	14.00	17.50	21.00	24.50	28.00	33.00	34.00	38.50	40.00	53.00
(159)	(267)	(292)	(318)	(356)	(444)	(533)	(622)	(711)	(838)	(864)	(978)	(1016)	(1346)
B	6.97	8.00	9.09	10.47	12.72	15.47	17.87	21.30	23.98	25.71	28.19	27.40	31.34
(Open)	(177)	(203)	(231)	(266)	(323)	(393)	(454)	(541)	(609)	(653)	(716)	(696)	(796)
Wt.	61.73	66.00	97.00	154.32	282.19	445.33	462.97	573.20	1477.10	1763.70	2259.74	2976.24	4303.42
(159)	(28)	(29)	(44)	(70)	(128)	(202)	(210)	(260)	(670)	(800)	(1025)	(1350)	(1952)
Wt.	35.27	48.50	66.14	116.84	222.67	346.13	511.47	912.71	1003.10	1688.74	1706.38	2116.44	3950.68
(159½)	(16)	(22)	(30)	(53)	(101)	(157)	(232)	(414)	(455)	(766)	(774)	(960)	(1792)

(2) Flanged end and butt-weld valves share same face-to-face dimensions.

Class 600 • Bolted Cap

Figure 175

- Swing Check, Flanged

Figure 175½

- Swing Check, Butt Weld

Size Range:

- 2 through 12 inches
- (50 - 300 mm)

Pressure Temperature Rating

- Carbon Steel
- ASTM A216 Grade WCB
- 1480 psi @ -20°F to 100°F
- (102 bar @ -28°C to 37°C)

Material of Construction*

Description	Material
Body	ASTM A216 GR.WCB
Seat Ring	ASTM A105N + Alloy 6 Hardfaced
Disc	ASTM A216 GR.WCB + 13Cr Faced
Disc Washer	ASTM A29 GR.1020
Disc Nut Pin	ASTM A276 Type 410
Disc Nut	ASTM A29 GR.1045
Hinge	ASTM A216 GR.WCB
Hinge Pin	ASTM A182 GR.F6a
Bearing Bracket	ASTM A216 GR.WCB
Spring Washer	ASTM A29 GR.1045
Hex Bolt	ASTM A29 GR.1035
Gasket	304SS + Graphite
Cover Bolt	ASTM A193 GR.B7
Cover Bolt Nut	ASTM A194 GR.2H
Cover	ASTM A216 GR.WCB
Eye Bolt	ASTM A181
Nameplate	SS304
Screw	SS304

*Standard construction: WCB-Trim 8, other options are available.

Industry Standards

Steel Valves	ASME B16.34
Face-to-Face/End-to-End	ASME B16.10
Flange Dimensions	ASME B16.5
Weld End	ASME B.16.25
Testing	API 598
Basic Design	API 594

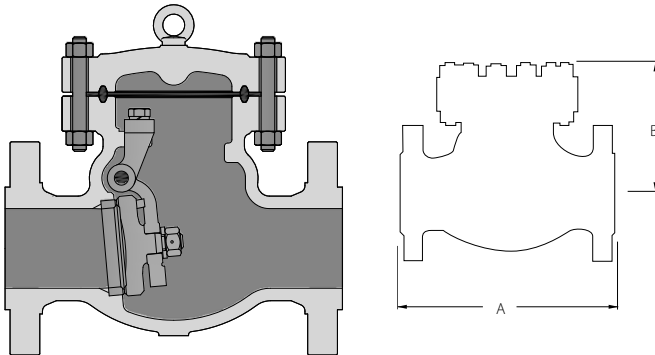

Dimensions and Weights

Inches (millimeters) - pounds (kilograms)

Valves	2	2 ½	3	4	6	8	10	12	14	16	18	20
	(50)	(65)	(80)	(100)	(150)	(200)	(250)	(300)	(350)	(400)	(450)	(500)
A	11.50	13.00	14.00	17.00	22.00	26.00	31.00	33.00	35.00	39.00	43.00	47.00
(175)	(292)	(330)	(356)	(432)	(559)	(660)	(787)	(838)	(889)	(991)	(1092)	(1194)
B	9.17	7.99	10.79	12.28	15.63	18.39	21.81	23.19	25.98	28.31	32.72	31.93
(Open)	(233)	(203)	(274)	(312)	(397)	(467)	(554)	(589)	(660)	(719)	(831)	(811)
Wt.	72.75	143.30	149.91	242.51	493.84	842.17	1309.55	1355.84	2105.41	2612.48	3571.49	4673.80
(175)	(33)	(65)	(68)	(110)	(224)	(382)	(594)	(615)	(955)	(1185)	(1620)	(2120)
Wt.	110.23	149.91	169.76	249.12	507.06	853.19	1393.32	1986.36	2511.07	3556.06	5842.25	7826.41
(175½)	(50)	(68)	(77)	(113)	(230)	(387)	(632)	(901)	(1139)	(1613)	(2650)	(3550)

(2) Flanged end and butt-weld valves share same face-to-face dimensions.

Class 900 • Bolted Cap

Figure 187

- Swing Check, Flanged

Figure 187½

- Swing Check, Butt Weld

Size Range:

- 2 through 12 inches
- (50 - 300 mm)

Pressure Temperature Rating

- Carbon Steel
- ASTM A216 Grade WCB
- 2220 psi @ -20°F to 100°F
- (153 bar @ -28°C to 37°C)

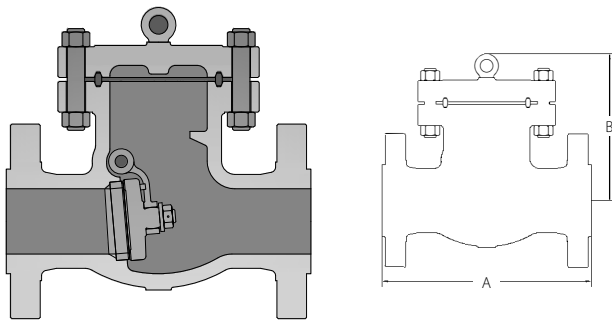

Material of Construction*

Description	Material
Body	ASTM A216 GR.WCB
Seat Ring	ASTM A105N +Alloy 6 Hardfaced
Disc	ASTM A216 GR.WCB+13Cr Faced
Disc Washer	ASTM A29 GR.1020
Disc Nut Pin	ASTM A276 Type 410
Disc Nut	ASTM A29 GR.1045
Hinge	ASTM A216 GR.WCB
Hinge Pin	ASTM A182 GR.F6a
Plug	ASTM A276 Type 410
Gasket Ring	Soft Steel
Cover Bolt	ASTM A193 GR.B7
Cover Bolt Nut	ASTM A194 GR.2H
Cover	ASTM A216 GR.WCB
Eye Bolt	ASTM A181
Nameplate	SS304
Screw	SS304

*Standard construction: WCB-Trim 8, other options are available.

Industry Standards

Steel Valves	ASME B16.34
Face-to-Face/End-to-End	ASME B16.10
Flange Dimensions	ASME B16.5
Weld End	ASME B.16.25
Testing	API 598
Basic Design	API 594

Dimensions and Weights

Inches (millimeters) - pounds (kilograms)

Valves	2 (50)	3 (80)	4 (100)	6 (150)	8 (200)	10 (250)	12 (300)
A	14.50	15.00	18.00	24.00	29.00	33.00	38.00
(187)	(368)	(381)	(457)	(610)	(737)	(838)	(965)
B	11.18	12.01	11.85	16.65	19.96	22.91	25.59
(Open)	(284)	(305)	(301)	(423)	(507)	(582)	(650)
Wt.	198.42	202.83	308.65	626.11	1113.33	1155.22	2380.99
(187)	(90)	(92)	(140)	(284)	(505)	(524)	(1080)
Wt.	198.42	200.62	308.65	626.11	1113.33	1433.00	1322.77
(187½)	(90)	(91)	(140)	(284)	(505)	(650)	(600)

(2) Flanged end and butt-weld valves share same face-to-face dimensions.

Class 1500 • Bolted Cap

Figure 199

- Swing Check, Flanged

Figure 199½

- Swing Check, Butt Weld

Size Range:

- 2 through 10 inches
- (50 - 250 mm)

Pressure Temperature Rating

- Carbon Steel
- ASTM A216 Grade WCB
- 3705 psi @ -20°F to 100°F
- (255 bar @ -28°C to 37°C)

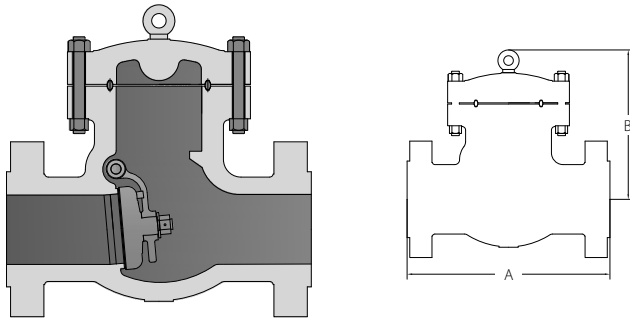

Material of Construction*

Description	Material
Body	ASTM A216 GR.WCB
Seat Ring	ASTM A105N +Alloy 6 Hardfaced
Disc	ASTM A216 GR.WCB+13Cr Faced
Disc Washer	ASTM A29 GR.1020
Disc Nut Pin	ASTM A276 Type 410
Disc Nut	ASTM A29 GR.1045
Hinge	ASTM A216 GR.WCB
Hinge Pin	ASTM A182 GR.F6a
Plug	ASTM A276 Type 410
Plug Gasket	ASTM A276 Type 316
Gasket Ring	Soft Steel
Cover Bolt	ASTM A193 GR.B?
Cover Bolt Nut	ASTM A194 GR.2H
Cover	ASTM A216 GR.WCB
Eye Bolt	ASTM A181
Nameplate	SS304
Screw	SS304

*Standard construction: WCB-Trim 8, other options are available.

Industry Standards

Steel Valves	ASME B16.34
Face-to-Face/End-to-End	ASME B16.10
Flange Dimensions	ASME B16.5
Weld End	ASME B.16.25
Testing	API 598
Basic Design	API 594

Dimensions and Weights

Inches (millimeters) - pounds (kilograms)

Valves	2 (50)	3 (80)	4 (100)	6 (150)	8 (200)	10 (250)
A	14.50	18.50	21.50	27.75	32.75	39.00
(199)	(368)	(470)	(546)	(705)	(832)	(991)
B	11.18	13.07	14.69	19.76	23.94	25.55
(Open)	(284)	(332)	(373)	(502)	(608)	(649)
Wt.	132.28	462.97	540.13	1697.56	1862.91	3284.89
(199)	(60)	(210)	(245)	(770)	(845)	(1490)
Wt.	110.23	253.53	418.88	996.49	1653.47	2231.08
(199½)	(50)	(115)	(190)	(452)	(750)	(1012)

(2) Flanged end and butt-weld valves share same face-to-face dimensions.

Pressure Temperature Ratings

ENGLISH UNITS

The following pressure-temperature charts are derived from ASME B16.34 – 2009 Version. They will cover the most commonly used body and bonnet materials in the industry. All Crane Valves are designed to operate through the pressure and temperature ranges shown in these charts for a particular ASME Class Rating and ASTM Material.

ASTM A216 GR WCB

°F	STANDARD CLASS B16.34 - 2009						SPECIAL CLASS B16.34 - 2009*					
	MAXIMUM NON-SHOCK WORKING PRESSURE, PSIG						MAXIMUM NON-SHOCK WORKING PRESSURE, PSIG					
	150	300	600	900	1500	2500	150	300	600	900	1500	2500
-20 to 100	285	740	1480	2220	3705	6170	290	750	1500	2250	3750	6250
200	260	680	1360	2035	3395	5655	290	750	1500	2250	3750	6250
300	230	655	1310	1965	3270	5450	285	740	1480	2220	3700	6170
400	200	635	1265	1900	3170	5280	280	735	1465	2200	3665	6105
500	170	605	1205	1810	3015	5025	280	735	1465	2200	3665	6105
600	140	570	1135	1705	2840	4730	280	735	1465	2200	3665	6105
650	125	550	1100	1650	2745	4575	275	715	1430	2145	3575	5960
700	110	530	1060	1590	2665	4425	265	690	1380	2075	3455	5760
750	95	505	1015	1520	2535	4230	245	635	1270	1905	3170	5285
800	80	410	825	1235	2055	3430	195	515	1030	1545	2570	4285

NOTE: Upon prolonged exposure to temperatures above 800°F (426°C), the carbide phase of steel may be converted to graphite. Permissible, but not recommended for prolonged use above 800°F (426°C).

ASTM A352 GR LCB

°F	STANDARD CLASS B16.34 - 2009						SPECIAL CLASS B16.34 - 2009*					
	MAXIMUM NON-SHOCK WORKING PRESSURE, PSIG						MAXIMUM NON-SHOCK WORKING PRESSURE, PSIG					
	150	300	600	900	1500	2500	150	300	600	900	1500	2500
-20 to 100	265	695	1395	2090	3480	5805	290	695	1395	2090	3480	5805
200	255	660	1320	1980	3300	5505	290	695	1395	2090	3480	5805
300	230	640	1275	1915	3190	5315	290	695	1395	2090	3480	5805
400	200	615	1230	1845	3075	5125	290	695	1395	2090	3480	5805
500	170	585	1175	1760	2930	4885	290	695	1395	2090	3480	5805
600	140	550	1105	1655	2755	4595	290	695	1395	2090	3480	5805
650	125	535	1065	1600	2665	4440	290	695	1390	2080	3470	5780

NOTE: Not to be used over 650°F (343°C).

ASTM A352 GR LCC & LC3

°F	STANDARD CLASS B16.34 - 2009						SPECIAL CLASS B16.34 - 2009*					
	MAXIMUM NON-SHOCK WORKING PRESSURE, PSIG						MAXIMUM NON-SHOCK WORKING PRESSURE, PSIG					
	150	300	600	900	1500	2500	150	300	600	900	1500	2500
-20 to 100	290	750	1500	2250	3750	6250	290	750	1500	2250	3750	6250
200	260	750	1500	2250	3750	6250	290	750	1500	2250	3750	6250
300	230	730	1455	2185	3640	6070	290	750	1500	2250	3750	6250
400	200	705	1405	2110	3520	5865	290	750	1500	2250	3750	6250
500	170	665	1330	1995	3325	5540	290	750	1500	2250	3750	6250
600	140	605	1210	1815	3025	5040	290	750	1500	2250	3750	6250
650	125	590	1175	1765	2940	4905	290	750	1500	2250	3750	6250

NOTE: Not to be used over 650°F (343°C).

* "Special Class" applies to weld-end valves only and requires NDE testing in accordance with ASME B16.34 - 2009.

ASME Pressure Temperature Ratings

ENGLISH UNITS

ASTM A217 GR WC6

°F	STANDARD CLASS B16.34 - 2009						SPECIAL CLASS B16.34 - 2009*					
	MAXIMUM NON-SHOCK WORKING PRESSURE, PSIG						MAXIMUM NON-SHOCK WORKING PRESSURE, PSIG					
	150	300	600	900	1500	2500	150	300	600	900	1500	2500
-20 to 100	290	750	1500	2250	3750	6250	290	750	1500	2250	3750	6250
200	260	750	1500	2250	3750	6250	290	750	1500	2250	3750	6250
300	230	720	1445	2165	3610	6015	290	750	1500	2250	3750	6250
400	200	695	1385	2080	3465	5775	290	750	1500	2250	3750	6250
500	170	665	1330	1995	3325	5540	290	750	1500	2250	3750	6250
600	140	605	1210	1815	3025	5040	290	750	1500	2250	3750	6250
650	125	590	1175	1765	2940	4905	290	750	1500	2250	3750	6250
700	110	570	1135	1705	2840	4730	280	735	1465	2200	3665	6110
750	95	530	1065	1595	2660	4430	280	730	1460	2185	3645	6070
800	80	510	1015	1525	2540	4230	275	720	1440	2160	3600	6000
850	65	485	975	1460	2435	4060	260	680	1355	2030	3385	5645
900	50	450	900	1350	2245	3745	225	585	1175	1760	2935	4895
950	35	320	640	955	1595	2655	155	400	795	1195	1995	3320
1000	20	215	430	650	1080	1800	105	270	540	810	1350	2250
1050	20(a)	145	290	430	720	1200	70	180	360	540	900	1500
1100	20(a)	95	190	290	480	800	45	120	240	360	600	1000

NOTE: Use normalized and tempered material only. Not to be used over 1100°F (593°C). The deliberate addition of any element not listed in ASTM A217, Table 1 is prohibited, except that Ca and Mg may be added for deoxidation.

(a) Flanged end valve ratings terminate at 1000°F (537°C).

ASTM A217 GR WC9

°F	STANDARD CLASS B16.34 - 2009						SPECIAL CLASS B16.34 - 2009*					
	MAXIMUM NON-SHOCK WORKING PRESSURE, PSIG						MAXIMUM NON-SHOCK WORKING PRESSURE, PSIG					
	150	300	600	900	1500	2500	150	300	600	900	1500	2500
-20 to 100	290	750	1500	2250	3750	6250	290	750	1500	2250	3750	6250
200	260	750	1500	2250	3750	6250	290	750	1500	2250	3750	6250
300	230	730	1455	2185	3640	6070	285	740	1480	2220	3695	6160
400	200	705	1410	2115	3530	5880	280	730	1455	2185	3640	6065
500	170	665	1330	1995	3325	5540	280	725	1450	2175	3620	6035
600	140	605	1210	1815	3025	5040	275	720	1440	2165	3605	6010
650	125	590	1175	1765	2940	4905	275	715	1430	2145	3580	5965
700	110	570	1135	1705	2840	4730	270	705	1415	2120	3535	5895
750	95	530	1065	1595	2660	4430	270	705	1415	2120	3535	5895
800	80	510	1015	1525	2540	4230	270	705	1415	2120	3535	5895
850	65	485	975	1460	2435	4060	260	680	1355	2030	3385	5645
900	50	450	900	1350	2245	3745	230	600	1200	1800	3000	5000
950	35	385	755	1160	1930	3220	180	470	945	1415	2360	3930
1000	20	265	535	800	1335	2230	130	335	670	1005	1670	2785
1050	20(a)	175	350	525	875	1455	85	220	435	655	1095	1820
1100	20(a)	110	220	330	550	915	55	135	275	410	685	1145

NOTE: Use normalized and tempered material only. Not to be used over 1100°F (593°C). The deliberate addition of any element not listed in ASTM A217, Table 1 is prohibited, except that Ca and Mg may be added for deoxidation.

(a) Flanged end valve ratings terminate at 1000°F (537°C).

* "Special Class" applies to weld-end valves only and requires NDE testing in accordance with ASME B16.34 - 2009.

ASME Pressure Temperature Ratings

ENGLISH UNITS

ASTM A217 GR C5

°F	STANDARD CLASS B16.34 - 2009						SPECIAL CLASS B16.34 - 2009*					
	MAXIMUM NON-SHOCK WORKING PRESSURE, PSIG						MAXIMUM NON-SHOCK WORKING PRESSURE, PSIG					
	150	300	600	900	1500	2500	150	300	600	900	1500	2500
-20 to 100	290	750	1500	2250	3750	6250	290	750	1500	2250	3750	6250
200	260	750	1500	2250	3750	6250	290	750	1500	2250	3750	6250
300	230	730	1445	2185	3640	6070	290	750	1500	2250	3750	6250
400	200	705	1410	2115	3530	5880	290	750	1500	2250	3750	6250
500	170	665	1330	1995	3325	5540	290	750	1500	2250	3750	6250
600	140	605	1210	1815	3025	5040	290	750	1500	2250	3750	6250
650	125	590	1175	1765	2940	4905	290	750	1500	2250	3750	6250
700	110	570	1135	1705	2840	4730	280	735	1465	2200	3665	6110
750	95	530	1065	1595	2660	4430	280	730	1460	2185	3645	6070
800	80	510	1015	1525	2540	4230	275	720	1440	2160v	3600	6000
850	65	485	975	1460	2435	4060	260	615	1225	1840	3065	5105
900	50	375	745	1120	1870	3115	230	465	935	1400	2335	3895
950	35	275	550	825	1370	2285	170	345	685	1030	1715	2855
1000	20	200	400	595	995	1655	125	250	495	745	1245	2070
1050	20(a)	145	290	430	720	1200	90	180	360	540	900	1500
1100	20(a)	100	200	300	495	830	60	125	250	375	620	1035
1150	20(a)	60	125	185	310	515	40	75	155	230	385	645
1200	15(a)	35	70	105	170	285	20	45	85	130	215	355

NOTE: Use normalized and tempered material only. The deliberate addition of any element not listed in ASTM A217, Table 1 is prohibited, except that Ca and Mg may be added for deoxidation.

(a) Flanged end valve ratings terminate at 1000°F (537°C).

ASTM A217 GR C12

°F	STANDARD CLASS B16.34 - 2009						SPECIAL CLASS B16.34 - 2009*					
	MAXIMUM NON-SHOCK WORKING PRESSURE, PSIG						MAXIMUM NON-SHOCK WORKING PRESSURE, PSIG					
	150	300	600	900	1500	2500	150	300	600	900	1500	2500
-20 to 100	290	750	1500	2250	3750	6250	290	750	1500	2250	3750	6250
200	260	750	1500	2250	3750	6250	290	750	1500	2250	3750	6250
300	230	730	1455	2185	3640	6070	290	750	1500	2250	3750	6250
400	200	705	1410	2115	3530	5880	290	750	1500	2250	3750	6250
500	170	665	1330	1995	3325	5540	290	750	1500	2250	3750	6250
600	140	605	1210	1815	3025	5040	290	750	1500	2250	3750	6250
650	125	590	1175	1765	2940	4905	290	750	1500	2250	3750	6250
700	110	570	1135	1705	2840	4730	280	735	1465	2200	3665	6110
750	95	530	1065	1595	2660	4430	280	730	1460	2185	3645	6070
800	80	510	1015	1525	2540	4230	275	720	1440	2160	3600	6000
850	65	485	975	1460	2435	4060	260	680	1355	2030	3385	5646
900	50	450	900	1350	2245	3745	230	600	1200	1800	3000	5000
950	35	375	755	1130	1885	3145	180	470	945	1415	2355	3930
1000	20	255	505	760	1270	2115	120	315	635	950	1585	2645
1050	20(a)	170	345	515	855	1430	80	215	430	645	1070	1785
1100	20(a)	115	225	340	565	945	55	140	285	425	705	1180
1150	20(a)	75	150	225	375	630	35	95	190	285	470	785
1200	20(a)	50	105	155	255	430	25	65	130	195	320	535

NOTE: Use normalized and tempered material only. The deliberate addition of any element not listed in ASTM A217, Table 1 is prohibited, except that Ca and Mg may be added for deoxidation.

(a) Flanged end valve ratings terminate at 1000°F (537°C).

* "Special Class" applies to weld-end valves only and requires NDE testing in accordance with ASME B16.34 - 2009.

Cv / Kv Values Gate Valves

Size	Figure 47 150lb		Figure 33 300lb		Figure 76 600lb		Figure 83 900lb		Figure 87 1500lb	
	Cv	Kv	Cv	Kv	Cv	Kv	Cv	Kv	Cv	Kv
2	267	231	267	231	267	231	244	211.1	244	211.1
2.5	428	370	428	370.2	428	370.2	400	346	400	346
3	632	547	632	546.7	632	546.7	580	501.7	532	460.2
4	1157	1001	1157	1000.9	1157	1000.9	1083	936.9	947	819.2
5	1924	1664.4	1924	1664.4	2090	1808	1845	1596	1600	1384
6	2771	2397.1	2771	2397.1	2771	2397.1	2466	2133.2	2149	1859
8	4926	4261.2	4926	4261.2	4766	4122.8	4329	3744.8	3771	3262.1
10	7697	6658.3	7697	6658.3	7319	6331.3	6994	6050.2	6101	5277.7
12	11083	9587.4	11083	9587.4	10629	9194.6	10219	8840	8890	7690.3
14	13990	12102.1	13990	12102.1	12747	11026.8	12916	11173	--	--
16	18531	16030.3	18531	16030.3	17335	14995.7	17614	15237	--	--
18	24604	21283.7	23913	20686	21688	18761.2	23387	20231	--	--
20	31892	27588.2	31062	26870.2	27539	23822.7	25095	20034	--	--
24	46520	40242.2	47542	41126.3	41645	36025.1	41567	35957.6	--	--
26	54867	47462.8	62335	53923	--	--	--	--	--	--
28	63903	55279.4	79775	69009.5	--	--	--	--	--	--
30	76899	66521.6	79356	68647.1	--	--	--	--	--	--
32		--	--	--	--	--	--	--	--	--
36	106895	92470	112189	97049	--	--	--	--	--	--
48	199447	172532	--	--	--	--	--	--	--	--
60	311849	269766	--	--	--	--	--	--	--	--

Cv / Kv Values Globe Valves

Size	Figure 143 150lb		Figure 151 300lb		Figure 171 600lb		Figure 183 900lb		Figure 189 1500lb	
	Cv	Kv	Cv	Kv	Cv	Kv	Cv	Kv	Cv	Kv
2	46	40	46	40	44	38	38	33	38	33
2.5	73	63	73	63	72	62	57	49	57	49
3	105	91	105	91	105	91	95	82	87	75
4	198	171	198	171	192	166	175	151	153	132
5	--	--	--	--	--	--	--	--	--	--
6	458	396	458	396	445	385	397	343	346	299
8	837	724	837	724	781	676	679	587	593	513
10	1405	1215	1405	1215	1294	1119	1087	940	--	--
12	2095	1812	2095	1812	1919	1660	1631	1411	--	--
14	2554	2209	2554	2209	2354	2036	--	--	--	--
16	3467	2999	3467	2999	3378	2922	--	--	--	--
18	--	--	--	--	--	--	--	--	--	--
20	--	--	--	--	--	--	--	--	--	--
24	--	--	--	--	--	--	--	--	--	--

Cv / Kv Values Swing Check Valves

Size	Figure 147 150lb		Figure 159 300lb		Figure 175 600lb		Figure 187 900lb		Figure 199 1500lb	
	Cv	Kv	Cv	Kv	Cv	Kv	Cv	Kv	Cv	Kv
2	121	104	121	104	119	103	105	90	105	90
2.5	191	166	190	166	190	166	169	146.2	169	146.2
3	284	246	284	246	284	246	260	225	260	225
4	520	450	520	450	520	450	502	434	474	410
5	--	--	--	--	--	--	--	--	--	--
6	1247	1079	1247	1079	1247	1079	1192	1031	1113	963
8	2280	1972	2280	1972	2206	1908	2003	1733	1951	1688
10	3563	3082	3563	3082	3388	2931	3127	2705	2729	2361
12	5324	4606	5324	4606	5105	4416	4570	3953	3975	3439
14	6508	5630	6493	5617	6163	5331	--	--	--	--
16	8600	7439	8600	7439	8070	6981	--	--	--	--
18	11634	10064	11521	9966	10476	9062	--	--	--	--
20	14262	12337	14252	12329	12824	11093	--	--	--	--
24	21675	18750	20885	18067	18632	16118	--	--	--	--
26	--	--	--	--	--	--	--	--	--	--
28	--	--	--	--	--	--	--	--	--	--
30	--	--	--	--	--	--	--	--	--	--
32	--	--	--	--	--	--	--	--	--	--
36	--	--	--	--	--	--	--	--	--	--



Crane ChemPharma & Energy
 Crane Energy Headquarters
 4526 Research Forest Drive, Suite 400
 The Woodlands, Texas 77381 U.S.A
 Phone: +1 936-271-6500
 Fax +1 936-271-6510
 www.cranecpe.com



Sydney, Australia, Operations
 146–154 Dunheved Circuit
 St. Mary’s, N.S.W. 2760 Australia
 Tel.: + 61 (2) 9623-0234
 Fax.: + 61 (2) 9673-3870

CRANE Cast Steel Customer Service
 2129 3rd Avenue, S.E.
 Cullman, Alabama 35055
 Tel.: (1) 256-775-3800
 Fax.: (1) 256-775-3860

Ningjin, China Operations
 No. 8 Youyi Street Ningjin County
 Hebei Province, China 055550
 Tel: (86) 319-580-6651
 Fax: (86) 319-580-8661

brands you trust.



Crane Co., and its subsidiaries cannot accept responsibility for possible errors in catalogues, brochures, other printed materials, and website information. Crane Co. reserves the right to alter its products without notice, including products already on order provided that such alteration can be made without changes being necessary in specifications already agreed. All trademarks in this material are property of the Crane Co. or its subsidiaries. The Crane and Crane brands logotype, in alphabetical order, (ALOYCO®, CENTER LINE®, COMPAC-NOZ®, CRANE®, DEPA®, DUO-CHEK®, ELRO®, FLOWSEAL®, JENKINS®, KROMBACH®, NOZ-CHEK®, PACIFIC VALVES®, RESISTOFLEX®, REVO®, SAUNDERS®, STOCKHAM®, TRIANGLE®, UNI-CHEK®, WTA®, and XOMOX®) are registered trademarks of Crane Co. All rights reserved.