

RUBBER LINE DIAPHRAGM

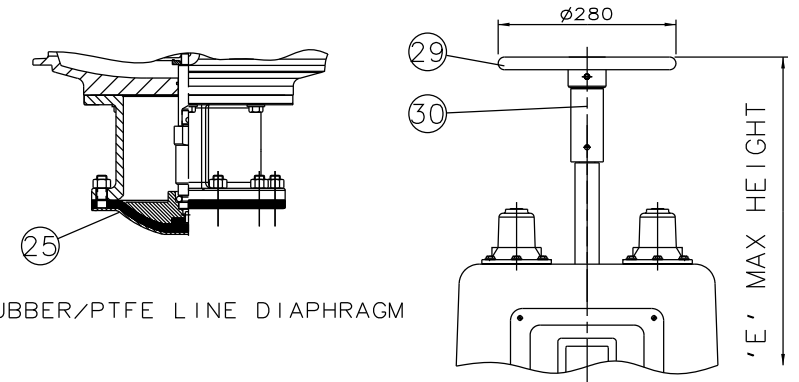

RUBBER/PTFE LINE DIAPHRAGM

EMERGENCY HANDWHEEL (OPTIONAL)

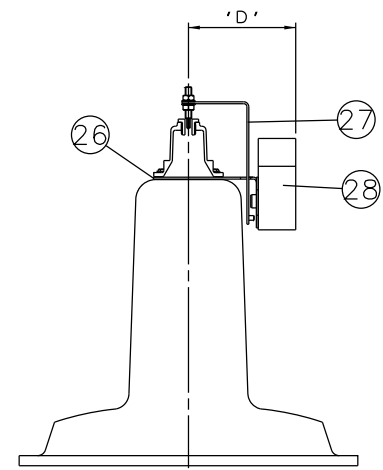

PMV POSITIONER (OPTIONAL)

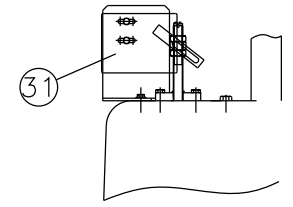

'007' SWITCHBOX (OPTIONAL)

Item	Component	Material	Lining
1	TRUST SLEEVE	MILD STEEL	
2	ADJUSTING SCREW	MILD STEEL	
3	SPRING COVER	SILICON ALUMINIUM	
4	INDICATOR ROD	STAINLESS STEEL	
5	WINDOW	STYRENE	
6	INDICATOR ADAPTOR	STAINLESS STEEL	
7	LIFTING ROD	MILD STEEL	
8	LIFTING ROD LOCKNUT	MILD STEEL	
9	UPPER SPRING PLATE	S.G. IRON	
10	SPRING	SPRING STEEL	
11	LOWER SPRING PLATE	S.G. IRON	
12	DIAPHRAGM PLATE	CAST IRON	
13	CLAMP WASHER	MILD STEEL	
14	LOWER CYLINDER O RING	RUBBER	
15	MASTER SPINDLE	STAINLESS STEEL	
16	BONNET	CAST IRON	
17	SPINDLE ATTACHMENT	STAINLESS STEEL	
18	COMPRESSOR PIN	STEEL	
19	COMPRESSOR	CAST IRON	
20	LINE DIAPHRAGM	RUBBER	
21	BODY	CAST IRON	HARD RUBBER
		SG IRON	SOFT RUBBER
		CAST STEEL	BUTYL RUBBER
			NEOPRENE RUBBER
22	COVER	SILICON ALUM.	
23	OPERATING DIAPHRAGM	RUBBER	
24	LOWER CYLINDER	SILICON ALUM.	
25	LINE DIAPHRAGM	RUBBER/PTFE	
26	MOUNTING BRACKET	STAINLESS STEEL	
27	MOUNTING BRACKET	STAINLESS STEEL	
28	POSITIONER	PMV	
29	HANDWHEEL	CAST IRON	
30	HANDWHEEL ADAPTOR	MILD STEEL	
31	'007' SWITCHBOX		

Size(DN)	A	B	C	D	E
100	1015	305	350	204	1145
125	1043	356	400	204	1073
150	1109	406	480	204	1239

The information on this sheet is Private and Confidential and is the property of Crane Process Flow Technologies Limited and must not be published directly or indirectly in any manner whatsoever without the written permission of the Company and must not be used in any way detrimental to their interests.
 © Crane Process Flow Technologies

CRANE	Process Flow Technologies A Crane Co. Company	Saunders The Science Inside
Title GENERAL ARRANGEMENT OF 'A' TYPE ES65 SPRING CLOSING MODULAR ACTUATOR (F8400) COMPLETE WITH OPTIONS FITTED ON RUBBER LINED FLANGED BODY		
Drawn RI	Date 15.06.13	UNCONTROLLED IN HARD COPY FORMAT
Checked RND	Date 15.06.13	
First Angle Projection Method E	DO NOT SCALE	Drawing No. A-ES65-RUBBER
		Issue. 1