

FK-Kugelhähne nach DIN 3357

mit Flanschanschluss PN 16 bis PN 40, Gehäuse in zweiteiliger Ausführung, voller Durchgang, Fire-safe-Design, mit antistatischer Ableitung, Schaltwelle ausblässicher, mit Aufbauflansch für Antriebe nach DIN ISO 5211, und Handbetätigung.

Standardausführung wartungsfrei mit federunterstützten Dachmanschetten, TA-Luft.

Baulängen nach DIN EN 558-1, Reihe 27 oder 28, Flanschanschlussmaße nach DIN 2501, Dichtleiste nach DIN 2526 Form C.

FK ball valves acc. to DIN3357

with flanged connection PN 16 to PN 40, body in two-piece design, full bore, fire-safe-design, with anti-static conductance, stem blow-off proof, with mounting flange for actuators acc. to DIN ISO 5211, with manual operation.

Standard design maintenance-free with spring loaded stem sealing, TA-Luft.

Face-to-face dimensions acc. to DIN EN 558-1, series 27 or 28, flange dimensions acc. to DIN 2501, sealing surface acc. to DIN 2526 Form C.

Bestell-Nr. Order No.	PN	Baulänge Face-to-face dimension	Gehäusewerkstoff Material	Werkstoff-Nr. Material No.
KH 1026	16/40	DIN EN 558-1, GR 27 Kurzbaulänge / Short dimension	Edelstahlguss / Stainless steel casting G-X5CrNiMo19-11-2	1.4408
KH 1027	16/40	DIN EN 558-1, GR 28 Langbaulänge / Long dimension	Edelstahlguss / Stainless steel casting G-X5CrNiMo19-11-2	1.4408
KH 1036	16/40	DIN EN 558-1, GR 27 Kurzbaulänge / Short dimension	warmfester Stahlguss / Steel casting GP240GH (GS-C25)	1.0619
KH 1037	16/40	DIN EN 558-1, GR 28 Langbaulänge / Long dimension	warmfester Stahlguss / Steel casting GP240GH (GS-C25)	1.0619

Kugelhähne

Ball Valves

Nr. 1025-1035

Standardausführung wartungsfrei mit federunterstützten Dachmanschetten
 Standard design maintenance-free with spring loaded stem sealing

DN 15 - 100: Typ / Type B-C
 DN 125 - 200: Typ / Type A-C

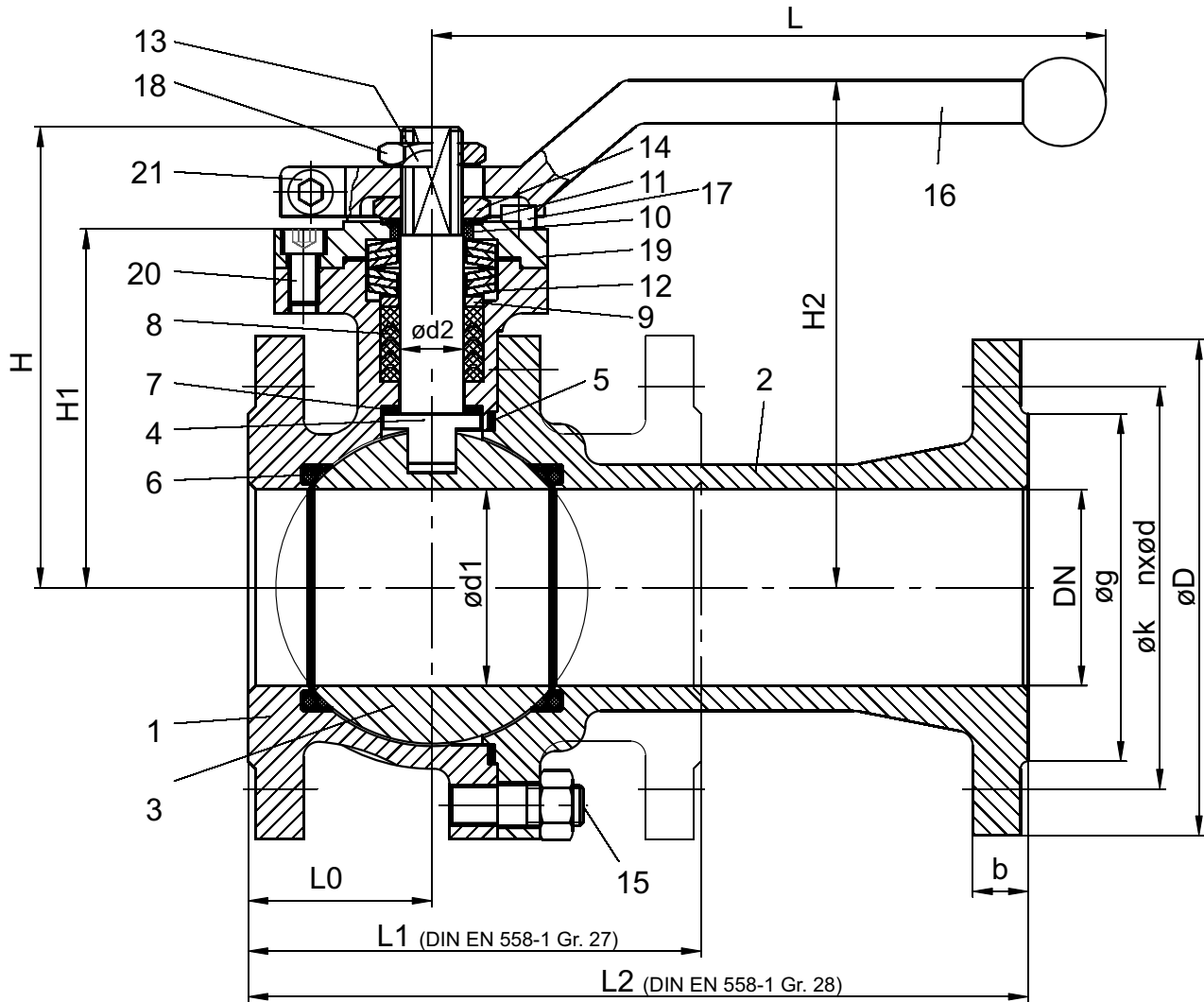

Handhebel mit Arretiervorrichtung
 (Bolzen gehört nicht zum Standardlieferumfang)

Hand lever with locking device
 (Pin does not belong to the standard scope of supply)

Kugelhähne

Ball Valves

Nr. 1025-1035

Ausführung doppelt gelagert
Design with double bearing

DN 150 - 300

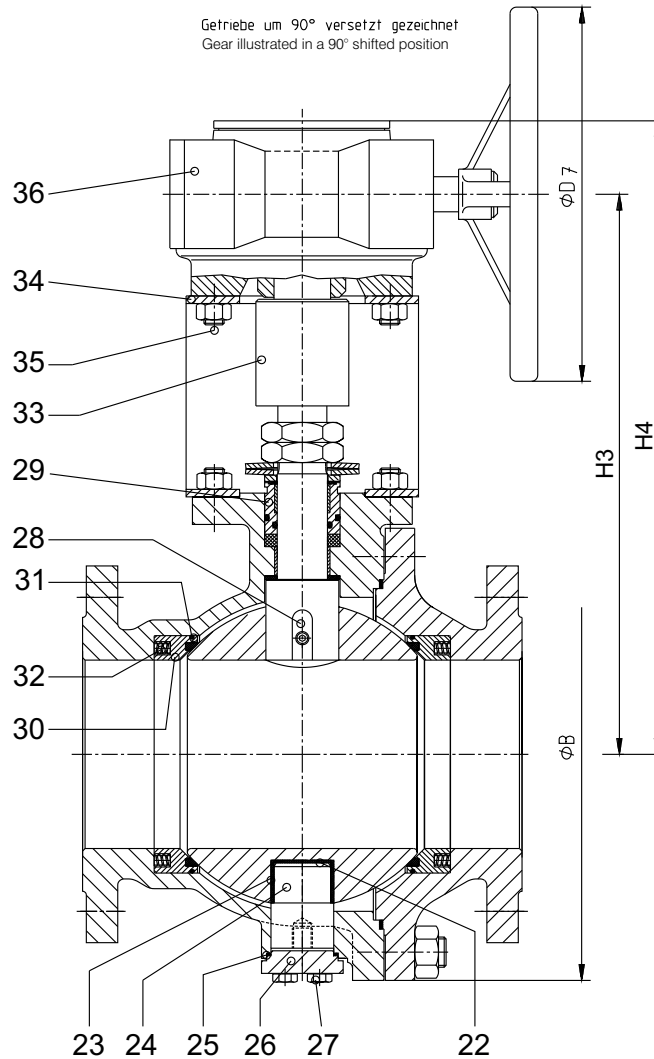

Mögliche Zertifikate
Possible certificates

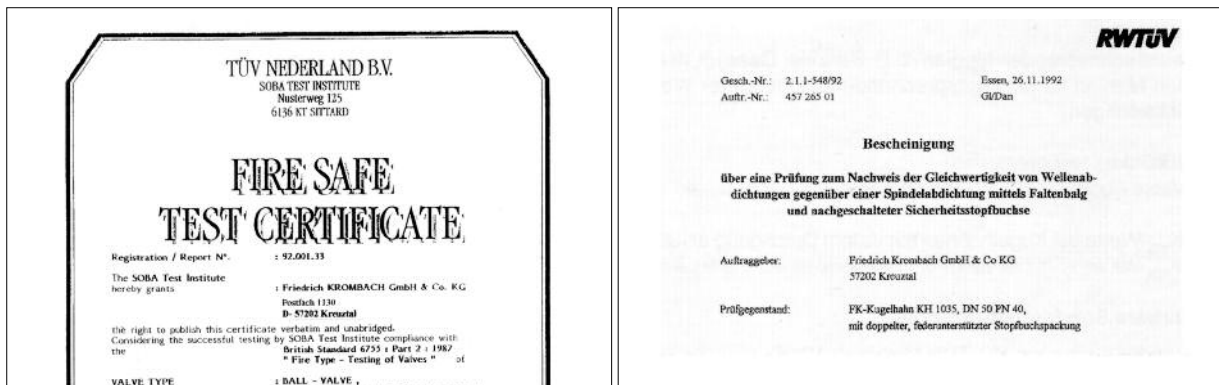

Aufbaumaße entsprechend DIN ISO 5211, Anschlüsse von Schwenkantrieben an Armaturen
 Mounting dimensions acc. to DIN ISO 5211, connections for part-turn valve actuators

Ausführung Typ A - C bzw. B - C
 Design type A - C or B - C

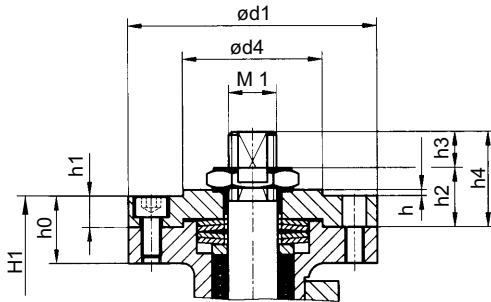

DN	15	20 - 25	32 - 65	80 - 125	150
DIN ISO 5211	F 05	F 05	F 07	F 10	F 14
d1	65	65	90	125	175
d2	50	50	70	102	140
n x M	4 x M6	4 x M6	4 x M8	4 x M10	4 x M16
d4	35	35	55	70	100
b	10	10	14	19	32
M1	M14x1,5	M14x1,5	M18x1,5	M24x2	M39x3
h	2	2	3	3	3
h0	16	18	19	34	55
h1	8	8	9	16,5	32
h2	19-17	19-17	24-22	33-31	68-66
h3	11-13	13-15	20-22	26-28	20-22
h4	30	32	44	59	88

DN 200 - DN 300:

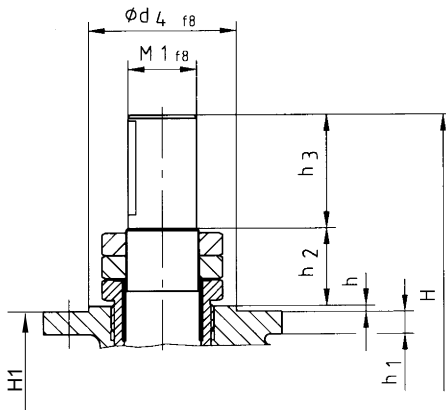

DN	200	200	250	300
PN	10 - 16	25 - 40	10 - 40	10 - 25
DIN ISO 5211	F 14	F 14	F 14	F 16
d1	175	175	175	219
d2	140	140	140	165
n x M	4 x M16	4 x M16	4 x M16	4 x M20
d4	100	100	100	130
M1	40	45	45	60
h	3	4	4	5
h1	17	21	18	20
h2	39	65	63	65
h3	62	71	100	120
H	363	400	450	530
b	2 x 12	14	2 x 14	18

Ausführung mit 1 Passfeder nach DIN 6885
 Design with 1 fitting key acc. to DIN 6885

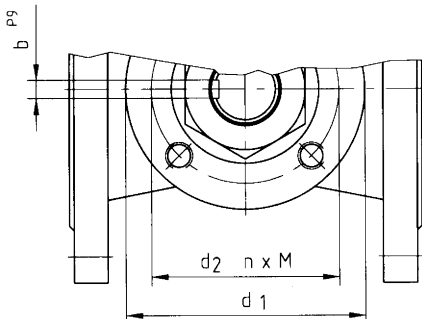

Ausführung mit 2 Passfedern nach DIN 6885
 Design with 2 fitting keys acc. to DIN 6885

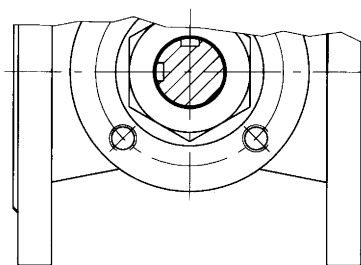

Abbildungen zeigen die Armaturen in Offenstellung
 Images show the valves in open position

Baumaße und Gewichte / Dimensions and weights

DN	PN	Baumaße Dimensions			Flanschanschlussmaße Flange dimensions						Ausbaumaße Dimensions							Gewicht Weight [kg]					
		L1	L2	L0	D	k	nxd	g	b	d1	d2	H	H1	H2	H3	H4	L	B	D7	L1	L2		
mit Handhebel / With hand lever																							
15	40	115	130	44	95	65	4x14	45	16	15	14	78	56	91	-	-	180	-	-	3,6	3,8		
20		120	150	44	105	75	4x14	58	18	20	14	88	61	101	-	-	180	-	-	4,7	5,2		
25		125	160	48	115	85	4x14	68	18	25	14	90	66	101	-	-	180	-	-	5,3	5,6		
32		130	180	56	140	100	4x18	78	18	32	18	123	88	143	-	-	280	-	-	9,6	10,2		
40		140	200	51	150	110	4x18	88	18	38	18	126	91	141	-	-	280	-	-	9,4	10		
50		150	230	61	165	125	4x18	102	20	50	18	134	99	149	-	-	280	-	-	12	13		
65	40	170	290	69	185	145	4x18	122	22	65	18	144	108	159	-	-	280	-	-	17,1	19,7		
40		170	290	69	185	145	8x18	122	22	65	18	144	108	159	-	-	280	-	-	17,1	19,7		
80	40	180	310	73	200	160	8x18	138	24	78	25	183	143,5	205	-	-	400	-	-	26	29		
40		180	310	73	200	160	8x18	138	24	78	25	183	143,5	205	-	-	400	-	-	26	29		
100	40	190	350	95	220	180	8x18	158	20	100	25	205	163,5	195	-	-	480	-	-	37	40		
40		190	350	95	235	190	8x22	162	24	100	25	205	163,5	195	-	-	480	-	-	38	41		
125	40	325	400	163	250	210	8x18	188	22	125	25	228	183,5	221	-	-	720	-	-	51	55		
40		325	400	163	270	220	8x26	188	26	125	25	228	183,5	221	-	-	720	-	-	56	60		
150	40	350	450	175	285	240	8x22	212	22	150	40	300	244	310	-	-	720	-	-	93	102		
mit Schneckengetriebe / With worm gear																							
150	40	350	450	175	300	250	8x26	218	28	150	40	-	244	-	447	494	-	360	250	113	122		
16	400	550	200	340	295	12x22	268	24	200	45	-	261	-	522	579	-	450	300	165	180			
200	40	400	550	200	360	310	12x26	278	30	200	50	-	261	-	522	579	-	430	300	175	190		
40		400	550	200	375	320	12x30	285	34	200	50	-	261	-	522	579	-	430	300	183	198		
250	40	450	650	225	405	355	12x36	320	26	250	50	-	300	-	561	618	-	500	300	280	330		
25		450	650	225	425	370	12x30	335	32	250	50	-	300	-	561	618	-	500	300	294	344		
40	450	650	225	450	385	12x33	345	38	250	50	-	300	-	561	618	-	500	300	302	362			
300	40	500	750	250	460	410	12x26	378	28	300	65	-	335	-	638	700	-	610	400	443	518		
25		500	750	250	485	430	16x30	395	34	300	65	-	335	-	638	700	-	610	400	460	535		

Werkstoffe / Materials

Pos. Item	Benennung	Designation	KH 1026 / KH 1027		KH 1036 / KH 1037	
			Werkstoffe/Material	W.-Nr./M. No.	Werkstoffe/Material	W.-Nr./M. No.
1	Gehäuse	Body	GX5CrNiMo19-11-2	1.4408	GP240GH (GS-C25)	1.0619
2	Anschraubteil	Flange part	GX5CrNiMo19-11-2	1.4408	GP240GH (GS-C25)	1.0619
3	Kugel	Ball	GX5CrNiMo19-11-2	1.4408	GX5CrNiMo19-11-2	1.4408
			X6CrNiMoTi17-12-2	1.4571	X6CrNiMoTi17-12-2	1.4571
4	Schaltwelle	Stem	X2CrNiMoN22-5-3	1.4462	X2CrNiMoN22-5-3	1.4462
5	Gehäusedichtung	Body sealing	PTFE (Fire-safe: Reingrafit) / PTFE (Fire-safe: Pure graphite)			
6	Dichtschale	Seat	PTFE (TFM)			
7	Schaltwellendichtung	Stem sealing	PTFE			
8	Dachmanschetzensatz	Sealing	PTFE/PTFE leitfähig/Fire-safe: Reingrafit / PTFE/PTFE Conductive/Fire-safe: Pure graphite			
9	Druckring	Pressure ring	X6CrNiMoTi17-12-2	1.4571	X6CrNiMoTi17-12-2	1.4571
10	Führungsbuchse	Guiding bush	PTFE			
11	Gleitring	Sliding ring	PTFE/Kohle / PTFE/Coal			
12	Tellerfeder	Cup spring	X9CrNi18-8	1.4310	51CrV4	1.8159
			X7CrNiAl17-7	1.4568		
13	Sicherungsblech	Locking plate	X6CrNiMoTi17-12-2	1.4571	X6CrNiMoTi17-12-2	1.4571
14	Schaltwellenmutter	Stem nut	A4	-	A4	-
15	Stiftschraube	Stud bolt	A4-70	-	A4-70	-
16	Handhebel	Hand lever	Edelstahl / Stainless steel			
17	Anschlagschraube	Stop screw	A4	-	A4	-
18	Handhebelmutter	Hand lever nut	A4	-	A4	-
19	Anpressflansch	Press flange	X6CrNiMoTi17-12-2	1.4571	St	-
20	Zylinderschraube	Fillister head screw	A4-70	-	A2-70	-
21	Schraube mit Mutter	Screw with nut	A4	-	St	-
22	Scheibe	Disc	PTFE	-	PTFE	-
23	Buchse	Bush	IGLIDUR X	-	IGLIDUR X	-
24	Bolzen	Bolt	X6CrNiMoTi17-12-2	1.4571	X20Cr13	1.4021
25	Dichtung	Sealing	PTFE	-	PTFE	-
26	Deckel	Cover	X6CrNiMoTi17-12-2	1.4571	S235JRG2 (RSt37-2)	1.0038
27	Sk.-Schraube	Hexagon screw	A4-70	-	5.6	-
28	Passfeder	Locking key	X6CrNiMoTi17-12-2	1.4571	St	-
29	O-Ring Buchse	O-ring bushing	X6CrNiMoTi17-12-2	1.4571	X6CrNiMoTi17-12-2	1.4571
30	Haltering	Retaining ring	X6CrNiMoTi17-12-2	1.4571	St. vernickelt / St.-nickel-plated	-
31	O-Ring	O-ring	Viton	-	Viton	-
32	Druckfeder	Spring	X9CrNi18-8	1.4310	X9CrNi18-8	1.4310
33	Kupplung	Coupling	X20Cr13	1.4021	X20Cr13	1.4021
34	Konsole	Console	St. verzinkt / St. galvanized		St. verzinkt / St. galvanized	
35	Schraube	Screw	5.6	-	5.6	-
36	Schneckengetriebe	Worm gear	div.	-	div.	-

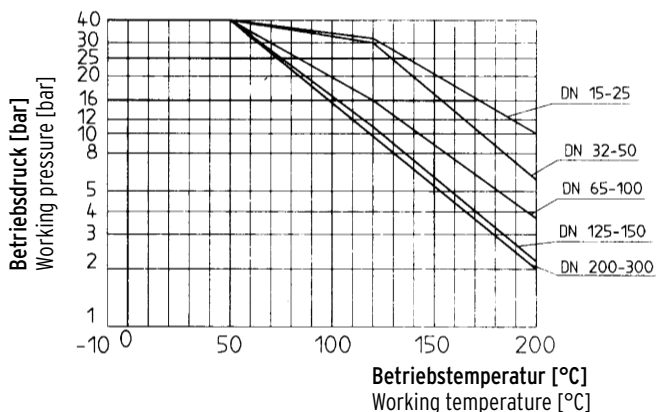

Andere Druck-Temperaturbereiche sind durch die Wahl anderer Dichtungswerkstoffe möglich.

Other pressure-temperature ranges are possible if other sealing materials are chosen.

Bei Temperaturen unter -10°C bitte AD-Merkblatt W 10 beachten.
At temperatures less -10°C, please heed to AD-Merkblatt W10.

Differenzdruck [bar] / Differential pressure [bar]					
DN	bis 10	16	25	40	Md. / Mt. zulässig / Allowable
15	10...13	11...15	11...15	12...16	44
20	12...16	13...17	13...17	14...18	62
25	15...20	16...21	16...21	17...22	62
32	30...38	32...41	33...43	35...45	115
40	35...43	37...48	39...50	40...52	115
50	50...65	53...68	55...72	58...75	115
65	60...78	63...82	66...86	69...90	115
80	70...91	74...96	77...100	81...105	450
100	100...130	105...137	110...143	115...150	450
125	170...220	190...250	220...285	255...330	450
150	350...450	450...590	550...720	630...820	1300
200	800...1000	800...1000	900...1200	1100...1450	1650
250	1300...1700	1400...1800	1600...2300	1800...2300	2630
300	1800...2400	2000...2600	2200...2800	2600...3400	6200

Anfahrdrehmomente [Nm]

Richtwerte für schmierende Medien
(z.B. Wasser, Öle bei 20°C)

Starting torques [Nm]
Standard values for lubricated mediums
(i.e. water, oils at 20°C)

Das Anfahrmoment wird erheblich durch die Schalthäufigkeit beeinflusst.

Der kleinere Wert der Tabelle entspricht häufiger Schaltung.
Der größere Wert entspricht längerem Stillstand.

ACHTUNG!

Bei nicht schmierenden Medien (z.B. Benzine, Gase) oder anhaftenden Medien ist eine entsprechende Erhöhung der Werte zu berücksichtigen

The starting torque is considerably influenced by the number of the shift frequency.

The smaller value of the table corresponds to shift frequency.
The greater value corresponds to a longer downtime.

ATTENTION!

If non-lubrication mediums (i.e. benzine, gases) or adhesive mediums are used an increasing of the values has to be considered.

Prüfdrücke

Gehäuse: 1,5 x PN Wasser, 6 bar Luft

Abschluss: 1,1 x Δp Wasser, 6 bar Luft

Test pressures

Body: 1,5 x PN water; 6 bar air

Seat: 1,1 x Δp water; 6 bar air

Die k_{vs} -Werte bei Kugelhähnen mit vollem Durchgang entsprechen den vergleichbaren Rohrlängen mit gleichem Durchmesser

The k_{vs} -values of ball valves with full bore correspond to the comparable pipe lengths with the same diameter.

Lieferbare Sonderausführungen:

- Fire-safe nach BS 6755 bzw. DIN EN ISO 10497
- mit Heizmantel (nur Baulänge DIN EN 558-1, GR 28)
- mit Schaltwellenverlängerung
- mit elektrischem, pneumatischem oder hydraulischem Antrieb
- mit anderer Flanschbearbeitung
- mit Druckentlastungsbohrung

Special designs:

- Fire-safe acc. to BS 6755 or DIN EN ISO 10497
- With heating jacket (only face-to-face dimensions DIN EN 558-1, series 28)
- With stem extension
- With electric, pneumatic or hydraulic actuator
- With other flange design
- With pressure relief bore

Die beschriebenen Armaturen entsprechen in Ihrer Konstruktion, ihren Abmessungen, Gewichten und Werkstoffen dem derzeitigen Stand der Technik. Änderungen im Zuge der Weiterentwicklung, sowie die Verwendung gleich- oder höherwertiger Werkstoffe bleiben vorbehalten. Für eventuelle Schreib- oder Übersetzungsfehler übernehmen wir keine Haftung. The construction, the measurements and the weights of the described valves represent the current technical standards. We reserve the right to change the technical details and to use materials of equivalent and higher quality. We cannot be held responsible for any printing or translation errors that might be found in this catalogue.

Friedrich Krombach GmbH Armaturenwerke

Marburger Straße 364 · D-57223 Kreuztal · Telefon +49 (0) 2732/520-00 · Fax +49 (0) 2732/520-100 · www.krombach.com · info@krombach.com